



GOBIERNO
DE ESPAÑA

MINISTERIO
PARA LA TRANSICIÓN ECOLÓGICA
Y EL RETO DEMOGRÁFICO



Hydrogen Roadmap: a commitment to renewable hydrogen

**MINISTRY FOR THE ECOLOGICAL TRANSITION AND THE
DEMOGRAPHIC CHALLENGE**

24/11/2020



MINISTERIO
PARA LA TRANSICIÓN ECOLÓGICA
Y EL RETO DEMOGRÁFICO

INDEX

0. CONTEXT

*I. HYDROGEN ROADMAP: A COMMITMENT TO
RENEWABLE HYDROGEN*

II. CALLS OF INTERESTS

III. H₂ PROJECTS



0. CONTEXT

Integrated National Energy and Climate Plan (INECP)

Measure 1.8. Promotion of gases renewable

- Role of H₂ renewable at long term:
 - Industry
 - Seasonal storage
 - Mobility
 - Synthetic fuels
- Specific gas plans renewable gases
 - Production potential and demand

Draft Law CC and ET

Article 10. Promotion of renewable gases

*The Government will encourage, through **approval of specific plans**, the penetration of renewable gases, including [...] **hydrogen** [...] in whose manufacture has been used **exclusively raw materials and energy from renewable sources** or allow the reuse of organic waste or by-products of animal or vegetable origin.*

Relevance

- ✓ **Hydrogen renewable** as one of the main energy vectors in the long term because its production and consumption **is climate neutral and does not generate polluting emissions**, with capacity to be stored as gas under pressure or in liquid state, which allows for a greater degree of manageability.
- ✓ Coherent with the **European Hydrogen Strategy**



MINISTERIO
PARA LA TRANSICIÓN ECOLÓGICA
Y EL RETO DEMOGRÁFICO

I. HYDROGEN ROADMAP: A COMMITMENT TO RENEWABLE HYDROGEN

Approved on October 6th 2020

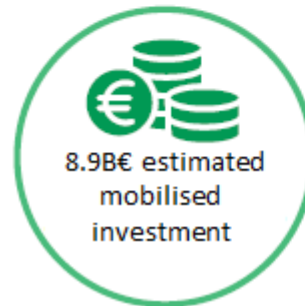
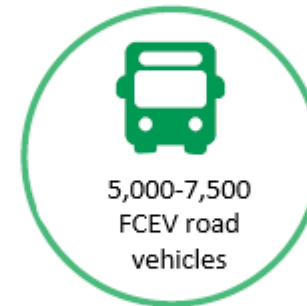
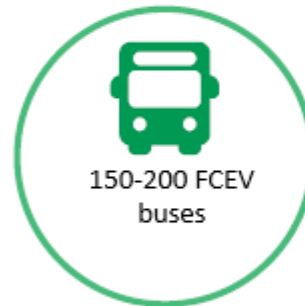

500,000 t/year hydrogen consumption, mostly grey hydrogen, mainly used as a raw material in refineries (around 70%) and chemical product manufacturers (25%)



MINISTERIO
PARA LA TRANSICIÓN ECOLÓGICA
Y EL RETO DEMOGRÁFICO

I. HYDROGEN ROADMAP: A COMMITMENT TO RENEWABLE HYDROGEN

Regulatory instruments

- Administrative simplification: production + supply facilities
- Public utility direct lines / hydro pipelines
- Renewable H₂ guarantee of origin system

Sectoral instruments

- Statistics: National H₂ statistics system
- Industry: penetration targets (trade mark) / financial instruments: support industrial adaptation / creation of *hydrogen valleys* + regional tables / **boosting the renewable H₂ value chain industry** in Spain to be a leader within the sector /
- Mobility: incentives for the purchase of vehicles + deployment of hydrogen generators (H₂ corridors) / transformation of diesel locomotives / specific regulations for hydrogen generators / promotion of synthetic biokerosene / support for shipyards / port infrastructure reloading / Sector integration: power to gas and possible participation in balancing services / network injection requirements / boiler combustion requirements





MINISTERIO
PARA LA TRANSICIÓN ECOLÓGICA
Y EL RETO DEMOGRÁFICO

I. HYDROGEN ROADMAP: A COMMITMENT TO RENEWABLE HYDROGEN

Transversal instruments

- Information and training: IDAE information hub / professional profiles
- Studies: potential production and consumption / socio-economic impact
- Contributing to just transition policies and tackling the demographic challenge
- International Dimension

Boosting R&D&I

- Role of H₂ in National Scientific and Technical Research and Innovation Plans
- Role of the CDTI and its funding lines
- Role of the NCH2 and international cooperation
- Promotion of specific technologies: combustion for electricity generation / large electrolysers / recycling elements
- Centres of excellence for research
- EU funding lines + EU Recovery Fund



MINISTERIO
PARA LA TRANSICIÓN ECOLÓGICA
Y EL RETO DEMOGRÁFICO

II. CALLS OF INTERESTS

Call of interest for RRPlan

- November 2020: Government announced **1,5 B€ of the European Funds** to boost green hydrogen development up to 2023.
- **Identify and locate renewable hydrogen solvent projects in Spain**, their impact on the entire value chain and industrial development, as well as on employment, and to learn about their transformative effect on the economy, decarbonisation and social and territorial cohesion.
- Call open up to 19 December 2020

Call of interest for IPCEI

- May 2020: the Spanish Ministry of Industry launched a call aiming to identify companies and projects willing to participate in H2 IPCEI. Only projects above 100.000 € of budget could be eligible.
- The project submission deadline ended in mid-June:
 - Number of project received: 27
 - Number of companies: 22
 - Type of projects: production of H2 with solar panels, transport with dedicated pipelines, potential use in industry or mobility, also production of electrolyzers with improved technology, etc.



MINISTERIO
PARA LA TRANSICIÓN ECOLÓGICA
Y EL RETO DEMOGRÁFICO

III. H₂ PROJECTS

Puertollano

✓ **PUERTOLLANO. H2R for the fertilizer industry. Call for Innovation Fund.**

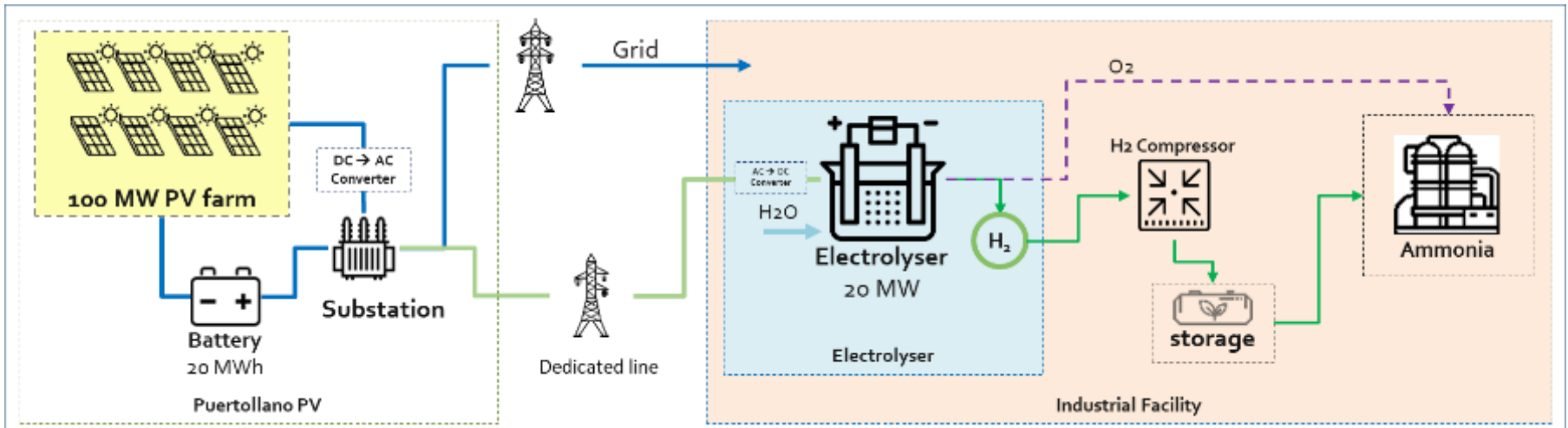

Dimension of the project:

- 20 MW of electrolysis (scalable)
- 100 MW solar photovoltaic
- 20 MWh battery

Location → Puertollano (Ciudad Real)

- Refinery
- Petrochemical area

End uses: Renewable hydrogen as a raw material for fertilizer production

Planned: 2nd installation. Up to 800MW of electrolyzers installed.



MINISTERIO
PARA LA TRANSICIÓN ECOLÓGICA
Y EL RETO DEMOGRÁFICO

III. H₂ PROJECTS Mallorca

✓ GREEN HYSLAND. Hydrogen for tourist demand (FCH JU. Islands topic)

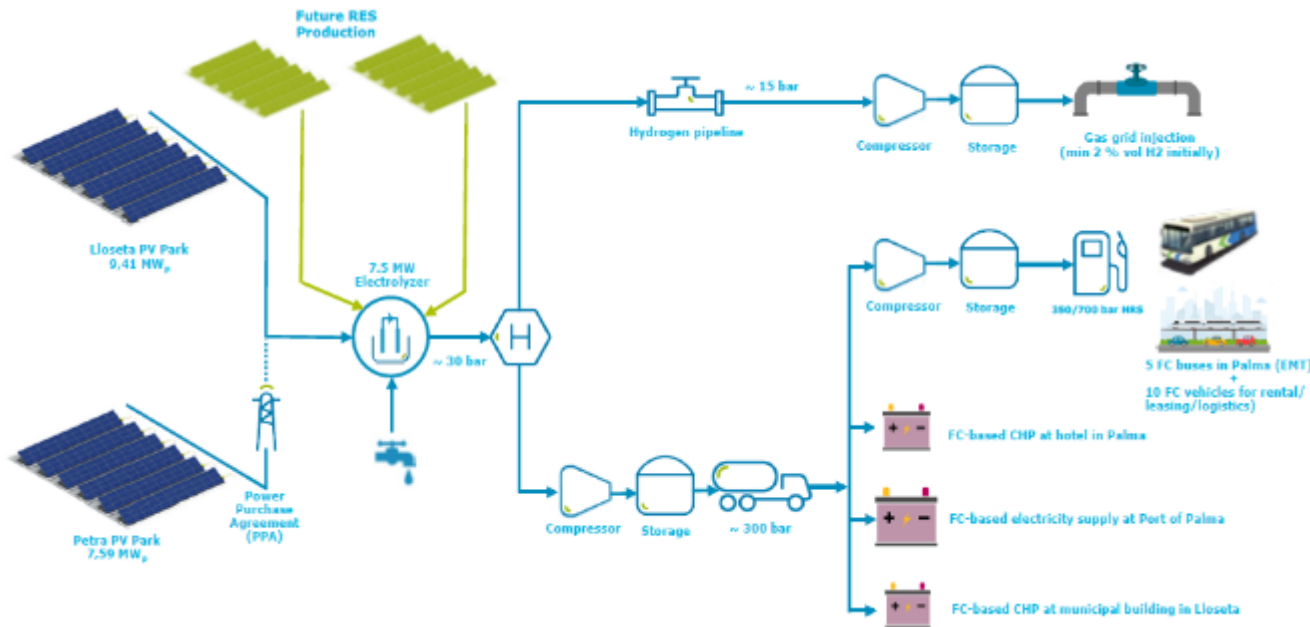

Dimension of the project:

- 7.5 MW electrolysis
- 16 MW solar photovoltaic

End uses

- Mobility (urban buses; rent-a-car; port services)
- Thermal (Hotels, public buildings)



Location → Lloseta (Island of Mallorca)

- Closure of cement production plant
- Turistic area



III. H₂ PROJECTS

Bilbao

✓ E-FUELS. Hydrogen for synthetic fuels

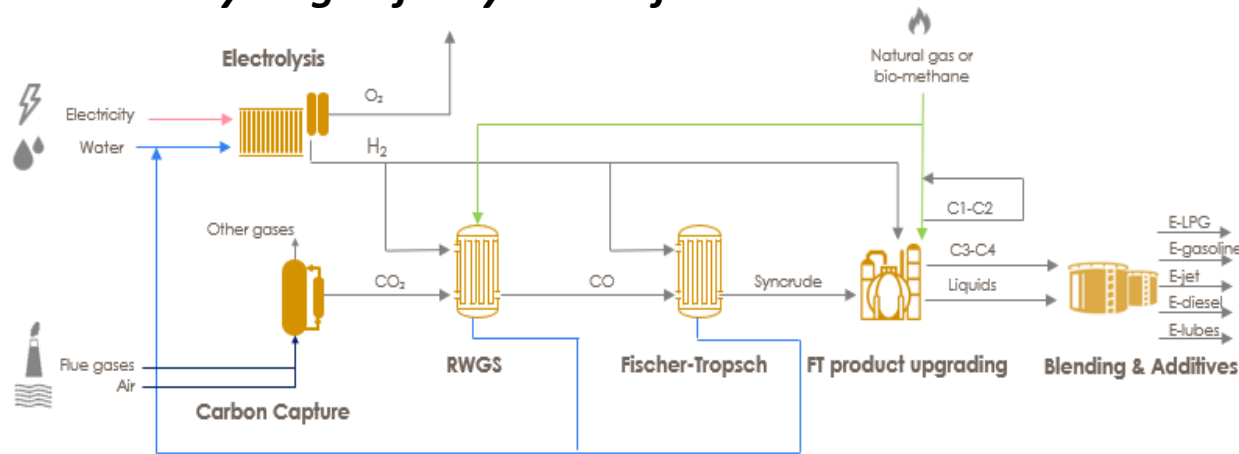

Location → Bilbao

- Refinery
- Heavy industry area
- Technological cluster
- Port and airport

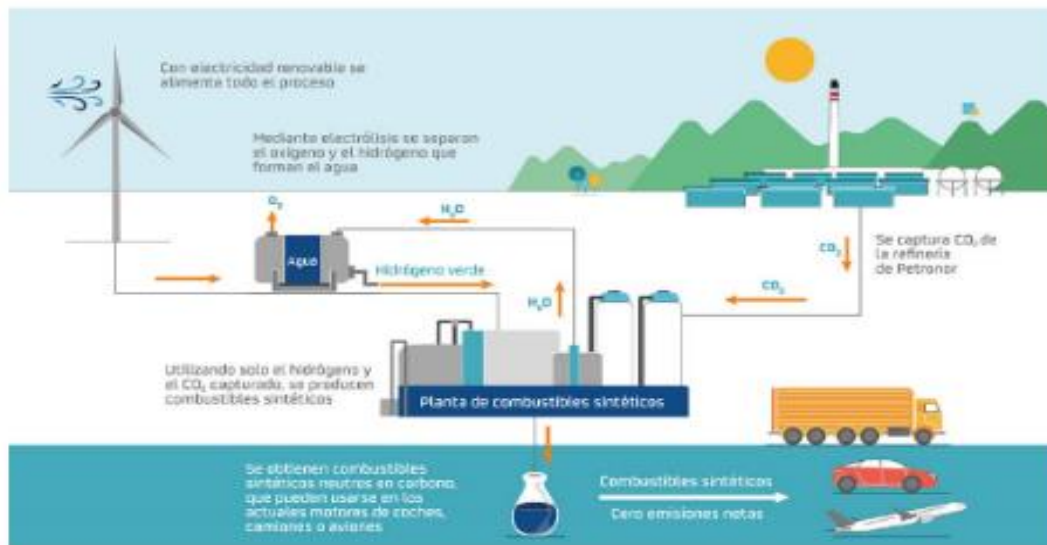

Dimension of the project

- 10-40 electrolysis (1st phase)
- 100 MW electrolyzer (2nd phase)
- Wind power installation

End uses

- Manufacturing synthetic fuels
- H₂ for direct use



MINISTERIO
PARA LA TRANSICIÓN ECOLÓGICA
Y EL RETO DEMOGRÁFICO

III. H₂ PROJECTS Cartagena

✓ *Hydrogen to reach zero net emissions refinery and production of advanced biofuels*

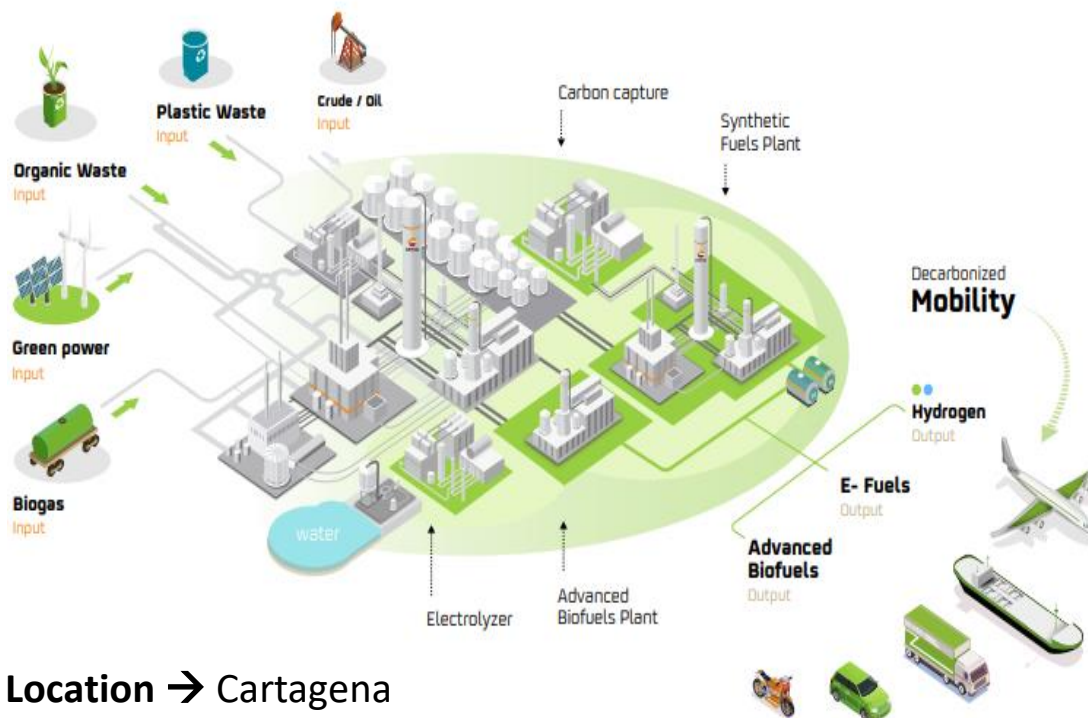

Location → Cartagena

- Refinery
- Heavy industry area

Dimension of the project

- 100 MW electrolysis
- Advanced biofuels production
- Carbon Capture
- Circular economy project

End uses:

- Decarbonization of the refinery
- Use in mobility



MINISTERIO
PARA LA TRANSICIÓN ECOLÓGICA
Y EL RETO DEMOGRÁFICO

III. H₂ PROJECTS

Other projects - Mobility

Public Transport

8 buses + 1 hydrogenerator

[Bidding in course](#)

Port of Valencia (H2Ports)

Handling equipment

FCH JU funds: 4 M€. Delivery: December 2022.

<https://h2ports.eu/>

Railway. Renfe & CNH₂

H₂ + LNG tests in a tunnel in Foundation Barredo (Asturias)

Project for CDTI's Proyectos Cien.

Sun2Hy (new technology)

Construction of a Photoelectrocatalysis plant to produce in 2025 10 ton h₂/day

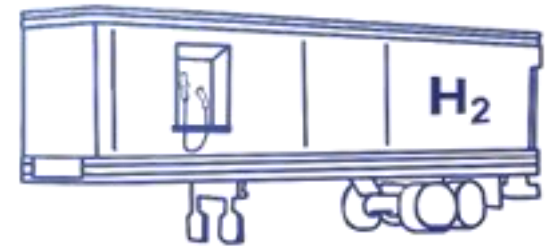



MINISTERIO
PARA LA TRANSICIÓN ECOLÓGICA
Y EL RETO DEMOGRÁFICO

Thank you for your attention