

Versatile technologies Integration for Biorefineries enabling multiple feedstocks, low energy costs, higher value revenue streams

SaincFlo™

BioFuel Scale
Continuous Flow Reactor

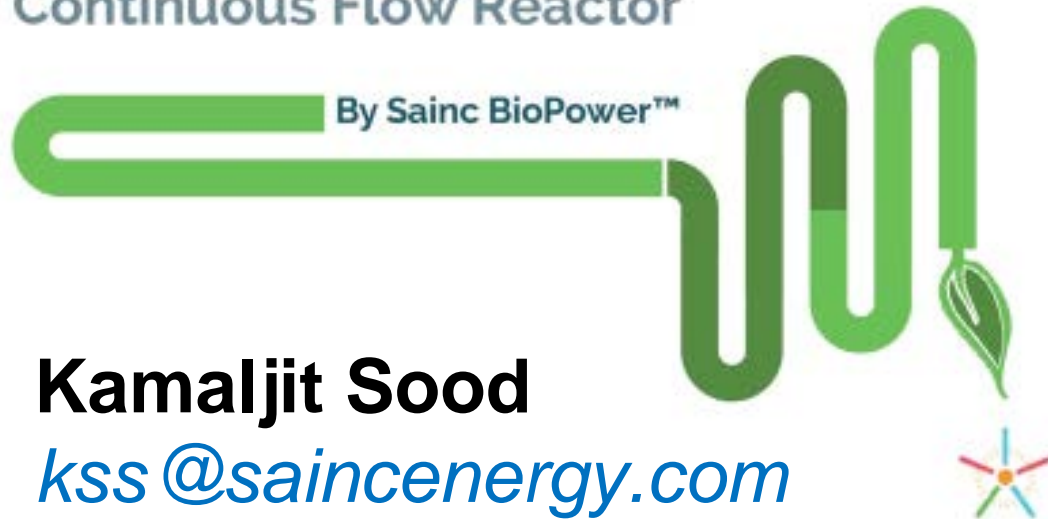

Kamaljit Sood

kss@saincenergy.com



C5-Sugar Isolation Technologies

Jagannadh Satyavolu, Ph.D.

J_Satyavolu@bioproductsllc.com



By Sainc BioPower™

About us

Sainc BioPower™, the technology sales operating brand of Sainc Energy.



With engineering

scale refinery,

Our main product is

the continuous

Flow Reactor SaincFlo™

BioProducts specializes in utilizing / integrating and process the bio products.



- C5 platform
- Biocoal and





- This presentation highlights the strong economic and technical benefits of the SaincFlo aspect of the technology.
- The Sainc Energy offering is for biorefineries in collaboration with **BIOPRODUCTS LLC, of Kentucky USA and its C5 sugar technology**
- The SaincFlo Reactor has been developed in collaboration with CINESTAV, Mexico.
- Sainc is developing a 180,000 tons pa biorefinery in Spain using Olive Tree Prunings as feedstock - branches, leaves, pomace - in other words variable feedstocks. Construction is expected to begin Q4 2020.
- BioProducts LLC is providing the Xylose production technology.



- a natural and zero calorie sugar.
- rapidly absorbed from the small intestine and not metabolized in the liver.
- a safe sugar - is used routinely in medical tests in the proximal small intestine.
- may help prevent progression of obesity-related metabolic disorders by improving lipid oxidation.
- also a sucrose inhibitor suggested to suppress development of obesity-related diseases
- Commercially available at xylitol – a modified sugar alcohol

Xylose market

SaincFlo™

BioFuel Scale Continuous Flow Reactor

By Sainc BioPower™



- Xylose is primarily used for xylitol production
- Global market for xylitol is estimated at 190.9 thousand metric tons, valued at US\$725.9 million in 2016
- Expected to reach 266.5 thousand metric tons valued at just above US\$1 billion by 2022
- Growing at robust CAGRs of around 5.7% in terms of both volume and value.

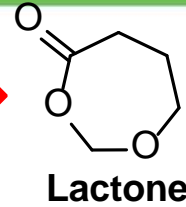
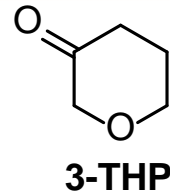
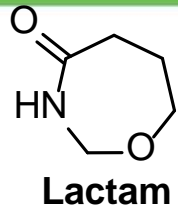

Applications
biodegradable polymers



DDG
Kenaf
Bagasse
Soy Hulls

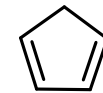
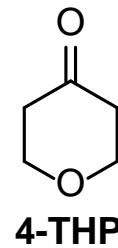
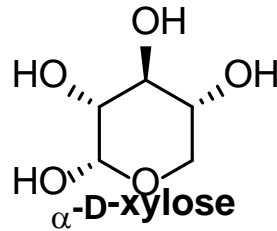

Applications
sweeteners
(xylitol)
food coloring

Applications
norbornene / cyclic olefin
copolymers (COC)

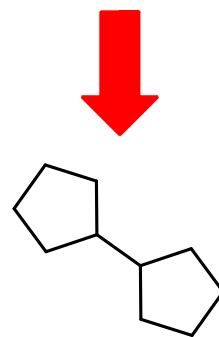

Applications
aviation fuel

BIOMASS

Sainc BioPower™, the technology sales operating brand of Sainc Energy . By Sainc BioPower™

The Driving force to develop integrated biorefineries is to:

- A versatile design that can use multiple feedstocks without incurring heavy retrofit costs.
- Multiple product lines at little or no additional capex costs
- Substantial savings in energy and processing material costs.
- Modular design.
- This plant could be structured around a payback period of atmost 3-4 years .
- The plant capex for a plant capacity of 10,000 tons per annum to 50,000 tons per annum of the order of €10 - 25 million for multiple feedstocks.

Major Applications of SaincFlo™

PRETREATMENT OF BIOMASS IN LIGNOCELLULOSIC BIOREFINERIES LEADING TO STEAM EXPLOSION

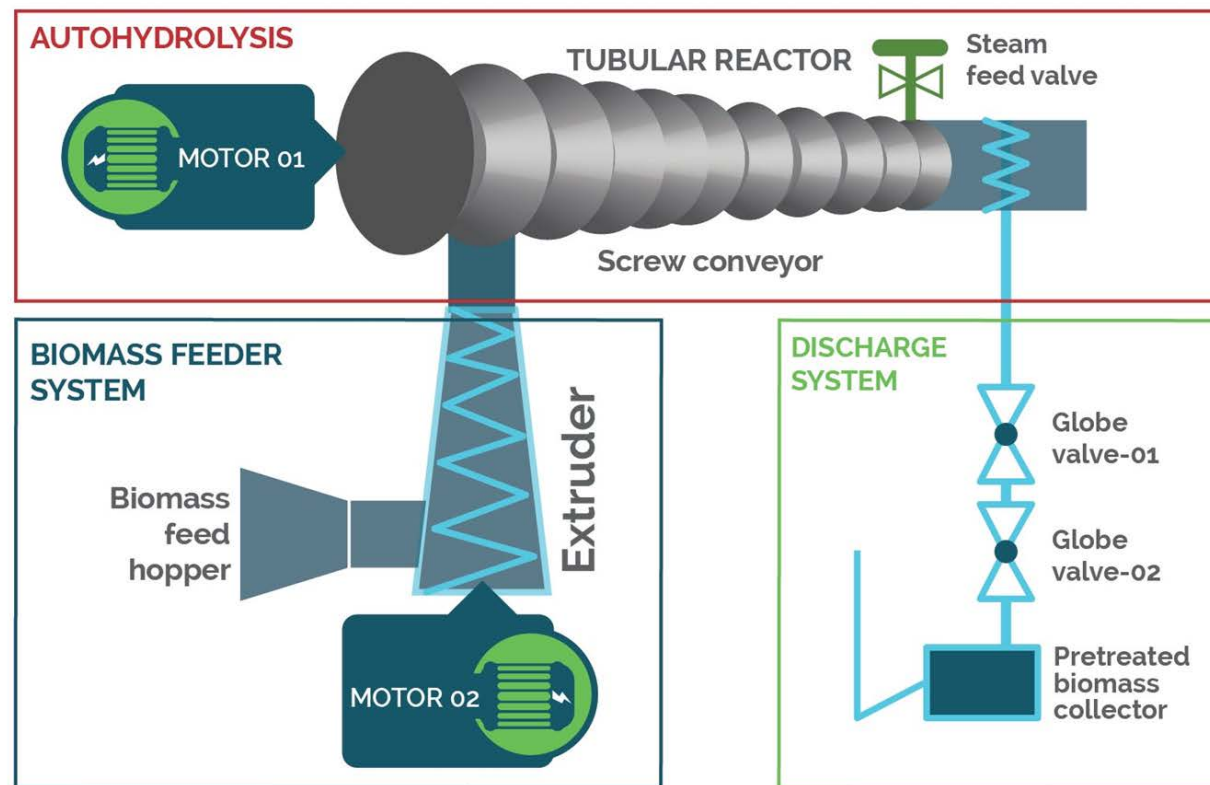



THE DEMO SCALE CONTINUOUS FLOW SAINCFLO™ REACTOR

N.º	N.º DE PIEZA	Descripción	CANT
1	CIN-RB3-ALI-Alimentación	Alimentación (HOKE ALI)	1
2	CIN-RB3-Ensamble Reactor principal	Reactor Principal (HOKE REC)	1
3	CIN-RB3-Cámara de expansión para bioreactor	Camara de expansión (HOKE CAM)	1

21/11/2017

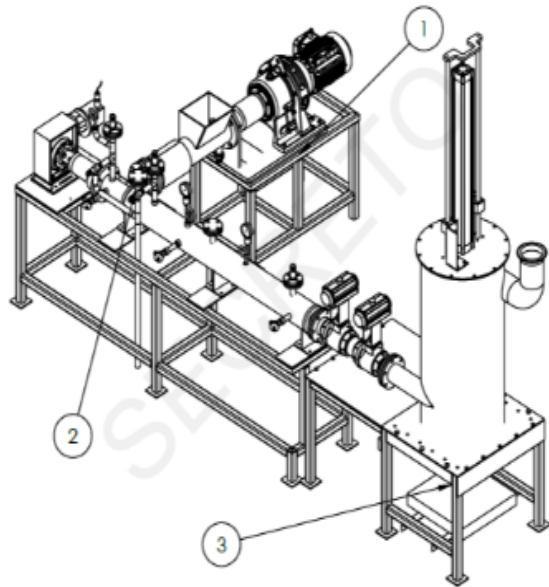

Figure 1. 50kg/h pretreatment continuous tubular reactor.



Figure 2. 5kg/h pretreatment continuous tubular reactor.



WHAT DOES SaincFlo™ DELIVER

Rapid scalability from pilot to demo scale and beyond

Continuous flow reactors with flow volumes ranging from 500L per hour to 20,000 L per hour

Upto 25% solids w/v in the liquid flow

Flow volumes large enough to provide adequate volume outputs of interest to industrial scale buyers

As stated before - profitable 2 -4 year payback for as low as 40,000 tons a year



Major Applications of SaincFlo™



❖ CATALYTIC DEPOLYMERISATION OF LIGNIN

Depolymerisation of lignin from black liquor - Membrane filtration following catalytic lignin depolymerisation

❖ DOUBLE CATALYST CONVERSION OF SUGARS

DMF, HMF, P-Xylene and other chemicals



Technology benefits of SaincFlo™

By Sainc BioPower™

- ▶ **SaincFlo™ static and dynamic mixers** are ideal for handling all kind of liquids, with low or high viscosity, with or without solids and available in many different metal and plastic configurations.
- ▶ Every mixer/agitator is **specified according to a customer's exact requirements** with the size, material, impeller type, motor requirements etc.
- ▶ **SaincFlo™ mixers are built and tested** in our testing and Research facility to guarantee the quality finish expected of a Sainc product. SaincFlo™ mixers are fabricated to exacting requirements by our specially appointed fabricators to guarantee the quality finish.
- ▶ **Clogging:** SaincFlo™ can pass debris **up to 50% of the diameter of the pipe**.
- ▶ **Higher Efficiency SaincFlo™** will mean **up to 300% increase** over the standard slurry heaters, tube and shell exchangers. It is typically installed in a circulation loop for large digester heaters, reducing retention time by up to 50%.

Components of SaincFlo™

SaincFlo™ De Heaters



a mixing module with a low pressure water injection spray nozzle that we carefully direct upstream. The flow of the steam causes that cone of water to reverse direction and pass downstream through the mixing module. The steam and water are then effectively combined with each other, reducing the superheat to the right value required for your mixture.

Components of SaincFlo™

In Line Static Mixture

The in-line static mixer saves energy costs, maintenance labor, reduces space requirements, and is consistent and efficient over the dilution/neutralisation system needs.

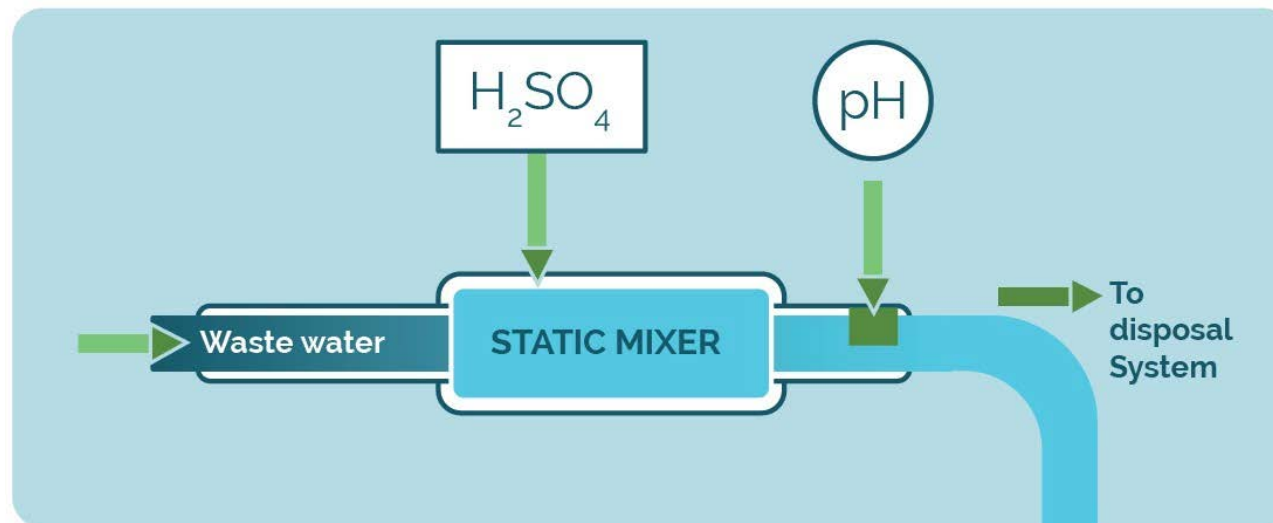

SaincFlo™ Single Tube Mixers

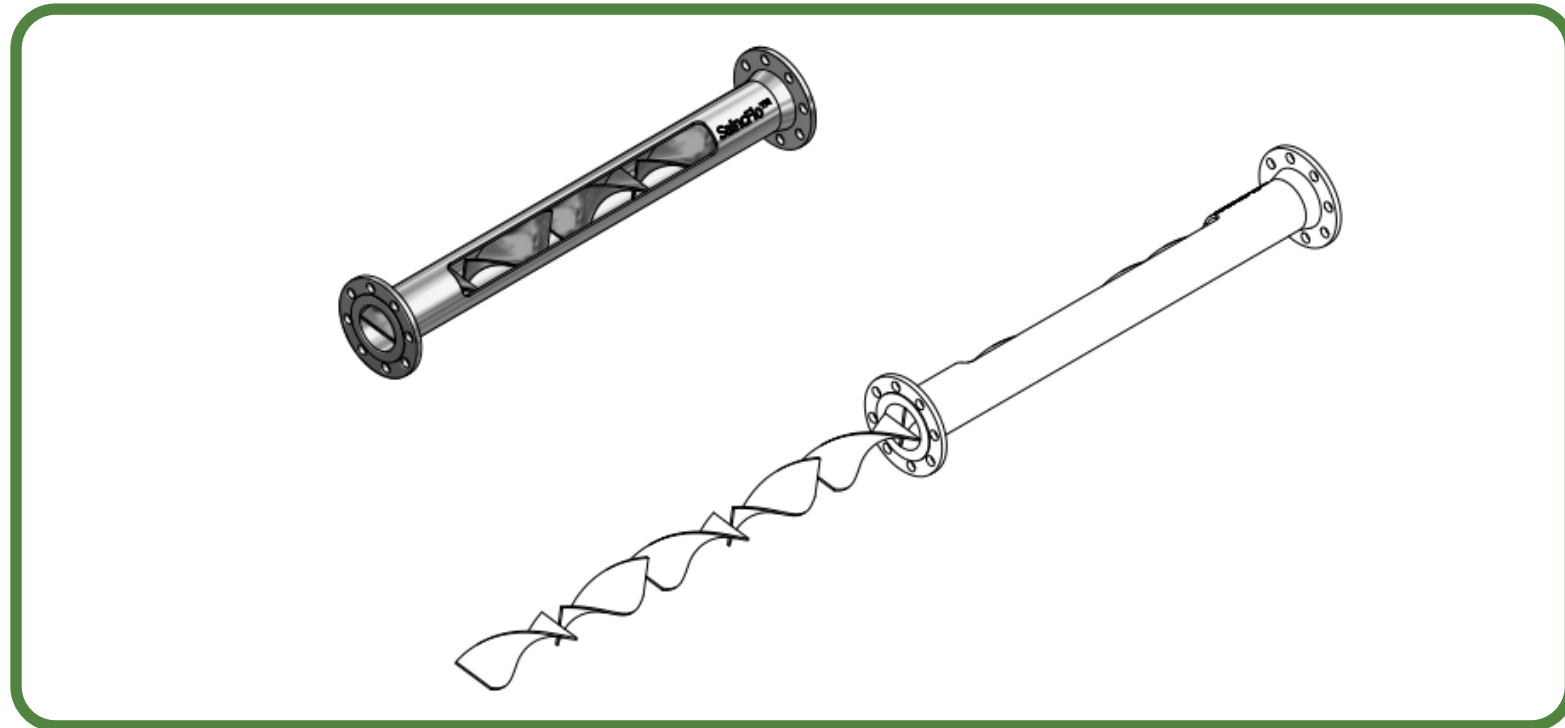



SaincFlo™ Multi -tube Mixers - Skid Mounted

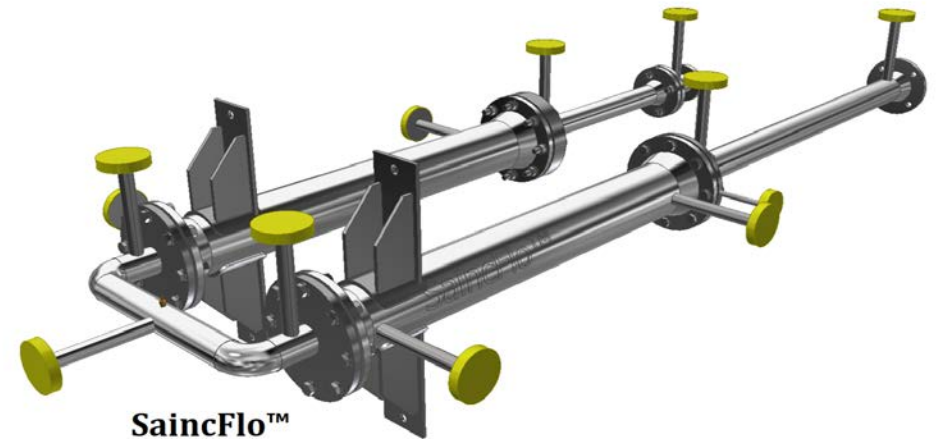
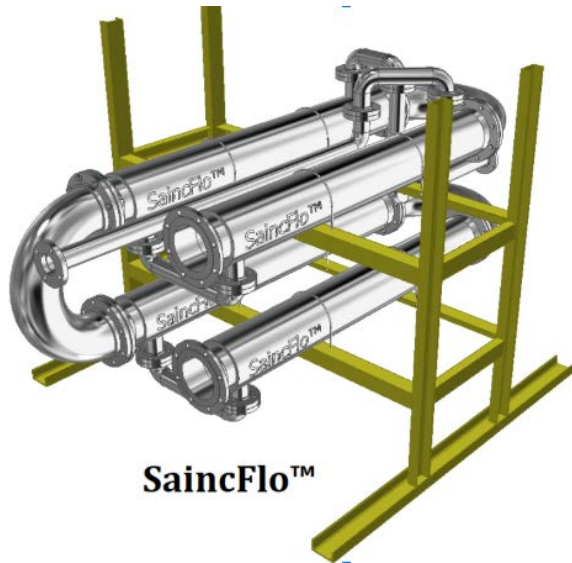

Where solutions are created

- ❖ We work with steel, austenite, Duplex, Hastelloy, Inconel, titanium and nickel.
- ❖ Static mixers made from PP, PE, PVC, PVDF or PTFE can likewise be supplied .

Approvals:

- AD 2000 HP0, Modul A2, CE, ISO 9001
- ASME U-Stamp and China Stamp, manufacture through a subcontractor

Research and development

In addition to continuously striving to perfect our mixing, heat transfer and reaction apparatus, we also conduct experiments in the SAINC laboratory and carry out development work on behalf of our customers. We normally use reference fluids for this purpose to guarantee comparable results.

SaincFlo™

BioFuel Scale Continuous Flow Reactor

By Sainc BioPower™

Thank you

SaincFlo™

BioFuel Scale
Continuous Flow Reactor

By Sainc BioPower™



C5-Sugar Isolation Technologies



Contact: SAINC ENERGY LIMITED. info@saincenergy.com

Sainc BioPower™ is a trade mark of Sainc Energy Limited. Sainc Energy develops and provide EPC for projects in renewable fuels, chemicals and electrical energy. Please visit www.saincenergy.com.

