



**CEN-CENELEC-ETSI Smart Grid Coordination Group**

**November 2012**

## **CEN-CENELEC-ETSI Smart Grid Coordination Group – Sustainable Processes**

## Contents

Page

Foreword.....	4
1 Scope .....	5
2 References.....	6
3 Terms and definitions .....	8
4 Symbols and abbreviations .....	13
5 Executive Summary.....	16
6 Use case methodology in standardization.....	20
6.1 Introduction .....	20
6.2 Background of use case method .....	20
6.3 The standardization mandate of the European Commission M/490 “Smart Grids” .....	21
6.4 Motivation of the use cases approach for standardization .....	21
6.5 Use case systematics and definitions .....	23
6.5.1 Use cases template .....	23
6.5.2 Multidimensional classification of use cases to allow different views .....	24
6.5.3 Use case structure / definitions of different use cases types.....	25
6.5.4 Use cases and systems .....	28
6.6 Use case processes .....	29
6.7 General process and methodology of defining use cases in relation to the overall process ....	30
6.8 The role of use cases in evaluating standards.....	32
6.9 Current processes .....	34
6.9.1 Steps taken by the SG-CG/SP until today .....	34
6.9.2 Intermediate process and next steps until a sustainable general work progress is installed .....	35
6.9.3 Suggestions for Standard Development Organizations (SDO) relevant for a sustainable use case approach.....	36
6.9.3.1 Background .....	36
6.9.3.2 Introduction .....	37
6.9.3.3 Status of use cases in standardization.....	37
6.9.3.4 Procedures for the maintenance of the IEC standards in database format.....	37
6.9.3.5 Use case database for standardization purposes .....	39
6.9.3.6 Utilization of existing IEC databases for use cases .....	39
7 Collection of use cases in the Smart Grid and analysis.....	41
8 Conceptual descriptions of the main use case clusters .....	42
8.1 Introduction .....	42
8.2 Conceptual description - demand and generation flexibility for technical and commercial operations.....	42
8.2.1 Introduction flexibility concept .....	42
8.2.1.1 Definitions.....	43
8.2.1.2 Providing and using flexibility .....	44
8.2.1.3 Smart Grid Connection Point (SGCP) .....	44
8.2.1.4 Flexibility functional architecture.....	45
8.2.2 Network user / customer providing flexibility - Introduction .....	47
8.2.2.1 Customer Energy Manager (CEM).....	47
8.2.3 The interaction of markets and use cases in relation to the delivery of flexibility services .....	49
8.2.3.1 Introduction .....	49
8.2.3.2 Current and future market roles, responsibilities and relationships.....	50

8.2.3.3	Assessing the impact of the use of 'flexible resources' on local network constraint management.....	52
8.2.3.4	Moving towards a 'smarter energy' future .....	53
8.2.3.5	Grid and market area – using the flexibilities .....	54
8.2.3.6	Use cases and market interactions – exploring the role of the flexibility operator .....	56
8.2.3.7	Open issues which are still under discussion.....	58
8.2.4	Recommendations .....	60
8.2.4.1	Auto registration of participating devices and customers.....	60
8.2.4.2	Recommendations from commercial / grid area .....	61
8.3	Conceptual description - Smart Charging .....	61
8.3.1	Introduction.....	61
8.3.2	Analysis of received smart charging use cases .....	61
8.3.3	Conceptual model .....	62
9	Generic use cases .....	65
9.1	Grid related generic use cases .....	68
9.1.1	Generic use case <i>Fault Location, Isolation and Restoration (FLIR)</i> – WGSP-0100.....	68
9.1.2	Generic high level use case <i>Voltage control and power flows optimization (VVO)</i> – WGSP-0200 .....	69
9.1.3	Generic high level use case <i>Short term load and generation forecasting</i> – WGSP-0301.....	69
9.1.4	Generic high level use case <i>Microgrid Management</i> – WGSP-0400 .....	70
9.1.5	Generic high level use case <i>Monitoring the distribution grid</i> – WGSP-0600.....	70
9.1.6	Generic high level use case <i>Emergency Signals</i> - WGSP-2300 .....	70
9.1.7	Generic use cases related to <i>Electric Vehicles charging</i> – WGSP-1000 .....	71
9.2	Suggested generic use cases related to the flexibility concept.....	71
9.2.1	Generic high level use case <i>Receiving consumption, price or environmental information for further action by consumer or a local energy manager-</i> WGSP-2110.....	71
9.2.2	Generic high level use case <i>Direct load / generation management</i> - WGSP-2120 .....	72
9.2.3	Generic high level use case <i>Flexibility offerings</i> - WGSP-2128 .....	72
9.2.4	Generic high level use case <i>Auto Registration of participating devices and customers</i> - WGSP-2130 .....	73
9.2.5	Generic high level use cases <i>Using Flexibility</i> - WGSP-2400.....	73
9.3	Analysis of the SG-CG/SP generic use cases .....	74
10	Description of the Use Case Management Repository (UCMR) .....	77
10.1	Necessary IT support .....	77
10.2	Collaborative editing process .....	79
10.3	Outlook for future additions .....	79
11	Outlook and identified issues .....	79
Annex A	Actors List .....	82
Annex B	Report about the work of the working group Sustainable Process SG-CG/SP .....	94
B.1	Description of use case template and selection list.....	96
B.2	Contributors to the use case collection.....	96
B.3	Analysis of the collected use cases .....	97
12	Bibliography.....	101

## Foreword

This draft document has been prepared by the Working Group *Sustainable Processes* (SG-CG/SP) which is working under the Smart Grid Coordination Group (SG-CG) established by the European Standardization Organizations CEN, CENELEC and ETSI in order to fulfill the tasks laid down in the Mandate M/490 of the European Commission [11]. Members of the SG-CG/SP followed an official call for experts.

Please note that some of the use cases might be subject of patent rights. CEN and CENELEC shall not be held responsible for identifying any or all such patent rights.

### Versions:

- Version 0.3 for internal comments
- Version 0.44 for first comments in the SG-CG (“Sanity Check”) for official commenting within the SG-CG and the associated organizations
- Version 0.5 provided to the European Commission as draft result for a deliverable of the Mandate M/490 and for official commenting within CEN, CENELEC, ETSI
- Version 0.65 provided to the CEN, CENELEC, ETSI

From the first to the final current draft, the report has undergone major changes: The report has partly been restructured following both stakeholder input and discussions within the SG-CG. It should be noted that in some instances elements of previous report versions have been shifted to annexes or the Use Case Management Repository (UCMR). This is not to negate their importance, but to ensure that the final report is both streamlined and accessible for a diverse audience. The use case definitions and the underlying process has been further refined and elaborated and in some instances new Generic Use Cases (GUC) included. It is also important to note that the flexibility concept outlined within this report has been revised. These revisions draw on the feedback received from the SG-CG and input elicited during an open stakeholder workshop held in May 2012. Furthermore, the SG-CG/SP organized another workshop focusing on the topic of smart charging. This output of this session has led to a further conceptual description and modifications to the smart charging GUC's.

- Version 1.0 (This version)

Main changes: The structure of the report as well as other editorial issues have been aligned within the SG-CG.

Annex A-C are now chapters 2-4, Annex D, G, H are integrated in new Annex B (former L). Annex E, K, J are moved into the UCMR.

Comments received for version 0.65 are integrated.

## SG-CG/M490/E - Part E:

# Smart Grid Use Case Management Process

## 1 Scope

The “Smart Grid Use Case Management Process” essentially describes the implementation of use cases in the standardization environment.

Drawing on the existing body of work around the application of ‘use cases’, a methodology was developed for this process which applied appropriate elements of use cases to the standardization development process. The rationale behind this was that the description of requirements and functions in use cases were seen as future starting point for the wider process outlined in other SG-CG documents [21]. Therefore, use cases can be seen as the basis for further developments such as the definition of reference architectures, investigations in risk analysis for information security or functional safety as well as standard development including the definition of profiles and test cases for interoperability.

Therefore, the contents of this document include:

- theoretical considerations relating to use case template and structures, classification of use cases according to several criteria and the process of use cases collection and maintenance,
- the practical development of Smart Grid use cases clusters along with their conceptual descriptions and related generic use cases, both reflecting use cases collected from the wider Smart Grid stakeholder community,
- the introduction and description of a use cases management repository (UCMR) developed as prototype which was subsequently successfully applied by the Working Group.

However, a major topic which was explored during this process was the development of a flexibility concept. The outline put forward in this concept is intended to aid stakeholder understanding and thus considers Smart Grid applications such as demand response. A further conceptual description deals with the process of electrical vehicle (EV) charging under a Smart Grid perspective.

Finally, it is important to recognize that within this report only the main work outputs are presented. For further information interested readers are encouraged to refer to the Use Cases Management Repository (UCMR [26]).

However, it should also be noted that it is not the intention of this document to set out a finalized and complete set of validated use case. This document should instead be seen as providing a general methodology and first array of valid examples for further consideration in the technical committees of the standardization organizations.

## 2 References

- [1] IEC PAS 62559:2008-01, *IntelliGrid Methodology for Developing Requirements for Energy Systems*.
- [2] ISO/IEC/TR 15067-3:2000-10, *Information technology - Home Electronic System (HES) application model - Part 3: Model of an energy management system for HES*.
- [3] ISO/IEC Directives Supplement, *Procedures specific to IEC, ISO/IEC DIR IEC SUP Edition 6.0 2011-04*
- [4] IEC 60050, *International Electrotechnical Vocabulary (IEV), series, online available as <http://www.electropedia.org/>*.
- [5] IEC 61360, *Standard data elements types with associated classification scheme for electric items, series, Component Data Dictionary (CDD)*.
- [6] IEC 61968 series, *Application integration at electric utilities - System interfaces for distribution management, [www.iec.ch](http://www.iec.ch)*.
- [7] Smart Grid Coordination Group, <http://www.cenelec.eu/aboutcenelec/whatwedo/technologysectors/smartgrids.html>
- [8] Smart Metering Coordination Group, <http://www.cenelec.eu/aboutcenelec/whatwedo/technologysectors/smartmetering.html>
- [9] IEC/TC 8, *New Work Item Proposal, 8/1307/NP*.
- [10] CEN/CLC/ETSI/TR 50572:2011-12, *Functional reference architecture for communications in smart metering systems*.
- [11] European Commission, *Smart Grid Mandate M/490, Standardization Mandate to European Standardisation Organisations (ESOs) to support European Smart Grid deployment Mandate M/490 Smart Grids, Responsible person: Dr. M SÁNCHEZ JIMÉNEZ (manuel.sanchez-jimenez@ec.europa.eu), Brussels, 2011*.
- [12] European Commission, *EG1 Report, Responsible person: Dr. M SÁNCHEZ JIMÉNEZ (manuel.sanchez-jimenez@ec.europa.eu), Brussels, 2010*.
- [13] CEN/CENELEC/ETSI Joint Working Group on Standards for Smart Grids, *"Final report of the CEN/CENELEC/ETSI Joint Working Group on Standards for Smart Grids", Brussels, 2011*.
- [14] CEN/CENELEC/ETSI Joint Working Group on Standards for Smart Grids, *"Recommendations for smart grid standardization in Europe Standards for Smart Grids", Brussels, 2011*.
- [15] UML Unified Modeling Language, *OMG, <http://www.uml.org/>*.
- [16] *OMG Unified Modeling Language (OMG UML), Superstructure, V2.1.2, pp. 586–588. <http://www.omg.org/spec/UML/2.1.2/Superstructure/PDF>*.
- [17] IEC Strategic Group 3 Smart Grids: *IEC Smart Grid Roadmap, <http://www.iec.ch/smartgrid/roadmap/>, Geneva, 2010*.
- [18] SG-CG – WG SP, *Use Case Description draft ver0.55.doc – Description of the modified use case template (used for the collection of use cases of the SG-CG/SP), Brussels, 2011*.

- [19] eBIX®, EFET and ENTSO-E Role Model,  
<http://www.ebix.org/content.aspx?ContentId=1117&SelectedMenu=8>  
and [https://www.entsoe.eu/resources/edi-library/EDI - Library: ENTSO-E Harmonised Electricity Role Model](https://www.entsoe.eu/resources/edi-library/EDI-Library:ENTSO-E-Harmonised-Electricity-Role-Model)
- [20] Additional European use cases, *ENTSO-E internet web site*, <https://www.entsoe.eu/resources/edi-library/>
- [21] SG-CG/M490/A Framework for Smart Grid Standardization
- [22] SG-CG/M490/B\_ Smart Grid First set of standards
- [23] SG-CG/M490/C\_ Smart Grid Reference Architecture
- [24] SG-CG/M490/D\_ Smart Grid Information Security
- [25] SG-CG/M490/E\_ Smart Grid Use Case Management Process (this document)
- [26] Use Case Management Repository (UCMR)

Link: <https://usecases.dke.de/sandbox/> (please use Browsers Chrome or Firefox)

Dummy User with Read-only rights

Name: LookatMe

Password: LookatMe

### 3 Terms and definitions

For the purposes of this document, the terms and definitions given in the actor list of annex A and the following apply.

#### Terms related to use cases and concepts

**3.1 use case**  
class specification of a sequence of actions, including variants, that a system (or other entity) can perform, interacting with actors of the system

[SOURCE: IEC 62559, ed.1 2008-01 - IEC 62390, ed 1.0:2005-01]

alternative: description of the possible sequences of interactions between the system under discussion and its external actors, related to a particular goal

[SOURCE: A. Cockburn "Writing effective use cases"]

NOTE A use case is the description of one or several functions performed by the respective actors.

**3.2 use case template**  
a form which allows the structured description of a use case in predefined fields

**3.3 cluster**  
group of use cases with a similar background or belonging to one system or one conceptual description

**3.4 high level use case**  
use case which describes a general requirement, idea or concept independently from a specific technical realization like an architectural solution

**3.5 primary use case**  
use cases which describe in detail the functionality of (a part of) a business process

NOTE Primary use cases can be related to a primary goal or function which can be mapped to one architectural solution.

**3.6 secondary use case**  
elementary use case which may be used by several other primary use cases

EXAMPLE communication functions

**3.7 generic use case**  
a use case which is broadly accepted for standardization, usually collecting and harmonizing different real use cases without being based on a project or technological specific solution

**3.8 specialized use case**  
use case which is using specific technological solutions / implementations



EXAMPLE Use case with a specific interface protocol

### 3.9

#### **individual use case**

use case which is used specific for a project or within a company / organization

### 3.10

#### **scenario**

a possible sequence of interactions

NOTE Scenario is used in the use case template defining one of several possible routes in the detailed description of sequences

### 3.11

#### **activity step**

is the one elementary step within a scenario representing the most granular description level of interactions in the use case

### 3.12

#### **repository**

here used for a place where information like use cases can be stored (-> Use Case Management Repository)

### 3.13

#### **Use Case Management Repository**

database for editing, maintenance and administration of use cases which are based on a given use cases template

NOTE The UCMR is designed as collaborative platform for standardization committees, inter alia equipped with export functionalities as UML model or text template

### 3.14

#### **actor**

entity that communicates and interacts

NOTE These actors can include people, software applications, systems, databases, and even the power system itself.

[based on IEC/PAS 62559]

NOTE In the actor list the ENTSO-E role model, generic actors and technical system actors are considered.

**3.15 actor [external]**

entity having behavior and interacting with the system under discussion (system as 'black box') to achieve a specific goal

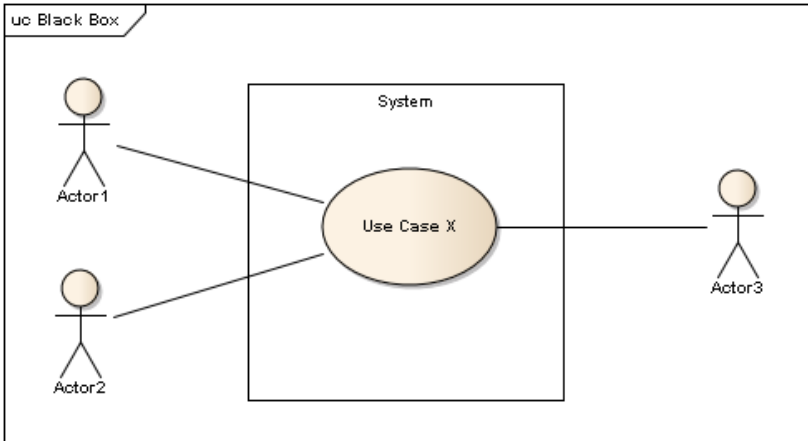

**Figure 1 – External actor definition**

**3.16 actor [internal]**

entity acting within the system under discussion (actor within the system; system as 'white box') to achieve a specific goal

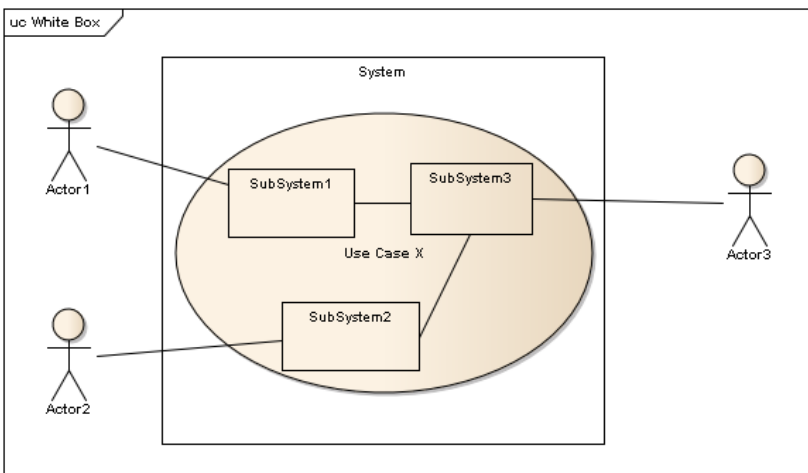

**Figure 2 – Internal actor definition**

**3.17 role**

role played by an actor in interaction with the system under discussion

NOTE Legally or generically defined external actors may be named and identified by their roles.

Alternative: A role represents the external intended behavior of a party. A party cannot share a role. [SOURCE: SG-CG/M490/C]

EXAMPLES A legally defined market participant (e.g. grid operator, customer), a generic role which represents a bundle of possible roles (e.g. flexibility operator) or an artificially defined body needed for generic process and use case descriptions.

### **3.18 architecture**

fundamental concepts or properties of a system in its environment embodied in its elements, relationships, and in the principles of its design and evolution

[SOURCE: SG-CG/M490/A]

### **3.19 system**

a typical industry arrangement of components and systems, based on a single architecture, serving a specific set of use cases.

[SOURCE: SG-CG/M490/B]

### **3.20 coordinating TC**

technical committee within a standardization organization taking over the responsibility for agreed use cases while involving other interested and concerned technical committees

NOTE For example the responsibility might include further detailing, analysis, maintenance and harmonization of the use case

### **3.21 involved TC**

technical committee within a standardization organization with an interest in a generic use case

### Terms related to the conceptual description of the flexibility concept

### **3.22 flexibility**

general concept of elasticity of resource deployment (demand, storage, generation) providing ancillary services for the grid stability and / or market optimization (change of power consumption, reduction of power feed-in, reactive power supply, etc.)

### **3.23 flexibility offer (short: Flex-offer)**

offer issued by roles connected to the grid and providing flexibility profiles in a fine-grained manner dynamically scheduled in near real-time, e.g. in case when the energy production from renewable energy sources deviates from the forecasted production of the energy system

NOTE Flexibility offer starts a negotiation process.

### **3.24 flexibility operator**

generic role which links the role *customer* and its possibility to provide flexibilities to the roles *market* and *grid*; generic role that could be taken by many stakeholders, such as a DSO company, an Energy Service Company (ESCO) or an energy supplier

### **3.25 market**

here: open platform operated by a market operator trading energy and power on requests of market participants placing orders and offers, where accepted offers are decided in a clearing process, usually by the market operator

EXAMPLES energy, balancing power / energy, capacities or in general ancillary services

### 3.26

#### **Smart Grid Connection Point (SGCP)**

borderline between the area of grid and markets towards the role *customer* (e.g. households, building, industry)

### 3.27

#### **customer energy manager (CEM)**

internal automation function of the role *customer* for optimizations according to the preferences of the customer, based on signals from outside and internal flexibilities

**EXAMPLE** A demand response approach uses variable tariffs to motivate the customer to shift consumption in a different time horizon (i.e. load shifting). On customer side the signals are automatically evaluated according to the preset customer preferences like cost optimization or CO2 savings and appropriate functions of one or more connected devices are initiated.

### 3.28

#### **Traffic Light Concept**

on one hand a concept which describes the relation between the use of flexibilities on the grid side (red phase) and the market side (green phase) and the interrelation between both (yellow phase), on the other hand a use case which evaluate the grid status (red, yellow, green) and provides the information towards the relevant market roles

### 3.29

#### **Demand Side Management (DSM) or Load Management**

measures taken by market roles (e.g. utilities, aggregator) controlling electricity demand as measure for operating the grid ("Top-down approach") (based on [28])

**ALTERNATIVE** In IEC 617-04-15 it is defined yet as: process that is intended to influence the quantity or patterns of use of electric energy consumed by end-use customers.

### 3.30

#### **Demand Response (DR),**

concept describing an incentivizing of customers by costs, ecological information or others in order to initiate a change in their consumption or feed-in pattern ("bottom-up approach" = Customer decides, based on [28])

**ALTERNATIVE** In IEC 617-04-15 it is defined yet as: action resulting from management of the electricity demand in response to supply conditions

#### Further terms related to generic use cases and concepts

### 3.31

#### **load shedding**

the process of deliberately disconnecting preselected loads from a power system in response to an abnormal condition in order to maintain the integrity of the remainder of the system

[SOURCE: IEC IEC Electropedia: reference 603-04-32]

### 3.32

#### **intelligent load shedding**

modified load shedding process where the selection of loads, which have to be disconnected, can be selected in a finer granularity using advanced control possibilities of the connected loads based on communication infrastructures.

### 3.33

#### **microgrid**

a low-voltage and/or medium-voltage grid equipped with additional installations aggregating and managing largely autonomously its own supply- and demand-side resources, optionally also in case of islanding

#### 4 Symbols and abbreviations

Abbreviation	Meaning
AD	Active Demand
AHG	Adhoc Group
BGC	Balancing Group Coordinator
BRP	Balancing Responsible Party
CD	Committee Draft
CDD	Component Data Dictionary (IEC / SC 3D)
CEM	Customer Energy Manager
CEN	European Committee for Standardization (Comité Européen de Normalisation)
CENELEC	European Committee for Electrotechnical Standardization (Comité Européen de Normalisation Electrotechnique)
CHP	Combined Heat and Power (Cogeneration)
CIM	Common Information Model (EN 61970 & EN 61968 series)
CR	Change Request
CPP	Critical Peak Pricing
CSO	Charge Service Operator
CSP	Charge Service Provider
CVPP	Commercial Virtual Power Plant
DB.	Database
DCT	Domain Core Team (inside IEC / TC 8 AHG 4)
DER	Distributed Energy Resources
DET	Data Element Type
DG	Distributed Generation
DMS	Distribution Management System
DNO	Distribution Network Operator
DR	Demand Response
DRS	Demand Response System
DSM	Demand Side Management
DSO	Distribution System Operator
EC	European Commission
EDR	Emergency Demand Response
EEX	European Energy Exchange
EG3	Expert Group 3 (of the EC Task Force Smart Grids)
EMC	Electromechanical Compatibility
EMG	Energy Management Gateway
ENTSO-E	European Network of Transmission System Operators for Electricity)
EPRI	Electric Power Research Institute
EPEX	European Power Exchange
ESCO	Energy Service Company
ESO	European Standard Organization
ET	Electrical Transportation
ETSI	European Telecommunications Standards Institute
EV	Electric Vehicles
EVSE	Electric Vehicle Supply Equipment
FACTS	Flexible AC Transmission System

Abbreviation	Meaning
FLIR	Fault Location, Isolation and Restoration
FN	Footnote
FO	Flexibility Operator
FSS	(Working Group) First set of standards
GUC	Generic Use Cases
HBES	Home and Building Electronic System
HES	Head End System
HL-UC	High Level Use Case
HV	High Voltage
ICT	Information and Communication Technology
IEC	International Electrotechnical Commission
IED	Intelligent Electronic Devices
IEV	International Electrotechnical Vocabulary
IT	Information Technology
JWG	Joint Working Group; here: Joint Working Group of CEN, CENELEC and ETSI on standards for smart grids
LNAP	Local Network Access Point
LTC	Load Tap Changer
LV	Low Voltage
M/490	Mandate issued by the European Commission to European Standardization Organizations (ESOs) to support European Smart Grid deployment [11]
MDM	Meter Data Management
NNAP	Neighbourhood Network Access Point
MG	Microgrid
MT	Maintenance Team
MV	Medium Voltage
NC	National Committee
OLTC	On Load Tap Changer
OTC	Over the Counter
PBR	Performance Based Rate
PEV	Plug-in Electric Vehicle
PUC	Primary Use Case
PV	Photovoltaic
R&D	Research and Development
RES	Renew Energy Sources
RFID	Radio-Frequency Identification
RTP	Real time pricing
RTSS	Real-time State Estimator
SAIDI	System Average Interruption Duration Index
SCADA	Supervisory Control and Data Acquisition
SDO	Standards Development Organization
SIDM	System Interfaces for the Distribution Management
SGAM	Smart Grid Architecture Model – delivered by the SG-CG-RA team as part of the mandated deliveries of M/490, which proposes 3 different axes to map a Smart Grid feature (Domains, Zones and Layers) – details available in SG-CG/M490/C
SG-CG	Smart Grid Co-ordination Group, reporting to CEN-CENELEC-ETSI and in charge of answering the M/490 mandate
SG-CG/FSS	Team of experts acting on behalf of the CEN-CENELEC-ETSI SG-CG to manage part of the mandated tasks as

Abbreviation	Meaning
	defined by SG-CG in the “First Set of Standards” package.
SG-CG/RA	Team of experts acting on behalf of the CEN-CENELEC-ETSI SG-CG to manage part of the mandated tasks as defined by SG-CG in the “Reference Architecture” package
SG-CG/SGIS	Team of experts acting on behalf of the CEN-CENELEC-ETSI SG-CG to manage part of the mandated tasks as defined by SG-CG in the “smart grid information security” package
SG-CG/SP	Team of experts acting on behalf of the CEN-CENELEC-ETSI SG-CG to manage part of the mandated tasks as defined by SG-CG in the “Sustainable Processes” package
SGCP	Smart Grid Connection Point
SGIS	Smart Grid Information Security
SGGWP	Smart Grid Good Working Practices
SM	Smart Metering System
SM-CG	Smart Metering Co-ordination Group, reporting to CEN-CENELEC-ETSI and in charge of answering the M/4441 mandate
SME	Small and Medium-sized Enterprise
SO	System Operator
TC	Technical Committee
TLC	Traffic Light Concept
TOU	Time-of-Use (tariff)
TR	Technical Report
TS	Technical Specification
TSO	Transmission System Operator
TVPP	Technical Virtual Power Plant
UCMR	Use Case Management Repository
UML	Unified Modelling Language
V2G	Vehicle to Grid
VPP	Virtual power Plant
VT	Here: Validation Team (see also VT as Voltage Transformer)
VVO	Volt Var Optimization
WGSP	Working Group Sustainable Processes, equal to SG-CG/SP, used for the numbering of GUC

## 5 Executive Summary

Based on the modified use case template, use cases have been collected from a diverse range of stakeholders. These use cases have been grouped and generic use cases have been suggested reflecting key stakeholder feedback around the provided use cases. Use cases can therefore be considered as essentially describing the functionality or requirements with respect to needs of an array of actors. Actors can be classified as people (their roles or jobs), systems, databases, organizations, and devices involved in or affected by the use case.

It was not the aim of the SG-CG/SP to determine as many use cases as possible. Instead the goal was to establish a prioritized list of high level use cases with respect to functioning of a Smart Grids. Use cases which are characterized as generic should be considered as describing the general concept and not a project specific outcome. Furthermore, generic use cases will be stored and maintained in the Use Case Management Repository (UCMR). Moreover, drawing on the suggested procedure other SG-CG working groups, such as the WG “First set of standards”, suggested further generic use cases.

It is worth noting that the suggested generic use cases have been discussed and reviewed following key stakeholder workshops. However, continuing this overall process it is expected that these generic use cases will be extended resulting in a first set of broadly accepted use cases. Also the specific role of use cases in standardization needs to be clarified. Further it is expected that together with the domain experts of the Technical Committees generic use cases will be further refined and interrelations and interdependencies will be investigated in more detail.

As described later in this document, the use cases developed in the context of the M/490 mandate, may serve as a basis to evaluate further Smart Grid standards.

Based on generic use cases a standardization gap analysis can thereafter be applied to support the different technical committees allowing them to draw on a consistent array of functional concepts within the Smart Grid (refer also to [21]). Therefore, use cases can be seen as part of a methodology to increase the collaboration between the various key stakeholder communities and sectors (e.g. smart metering, home automation, utilities, IT, appliances, manufacturers etc.) and their respective technical committees in standardization. A mapping of the use cases to the business and function layer of the proposed Smart Grid Reference Architecture (SGAM) established by the Working Group Reference Architecture (SG-CG/RA) is a further key element of supporting material to this generic use case analysis ([23]).



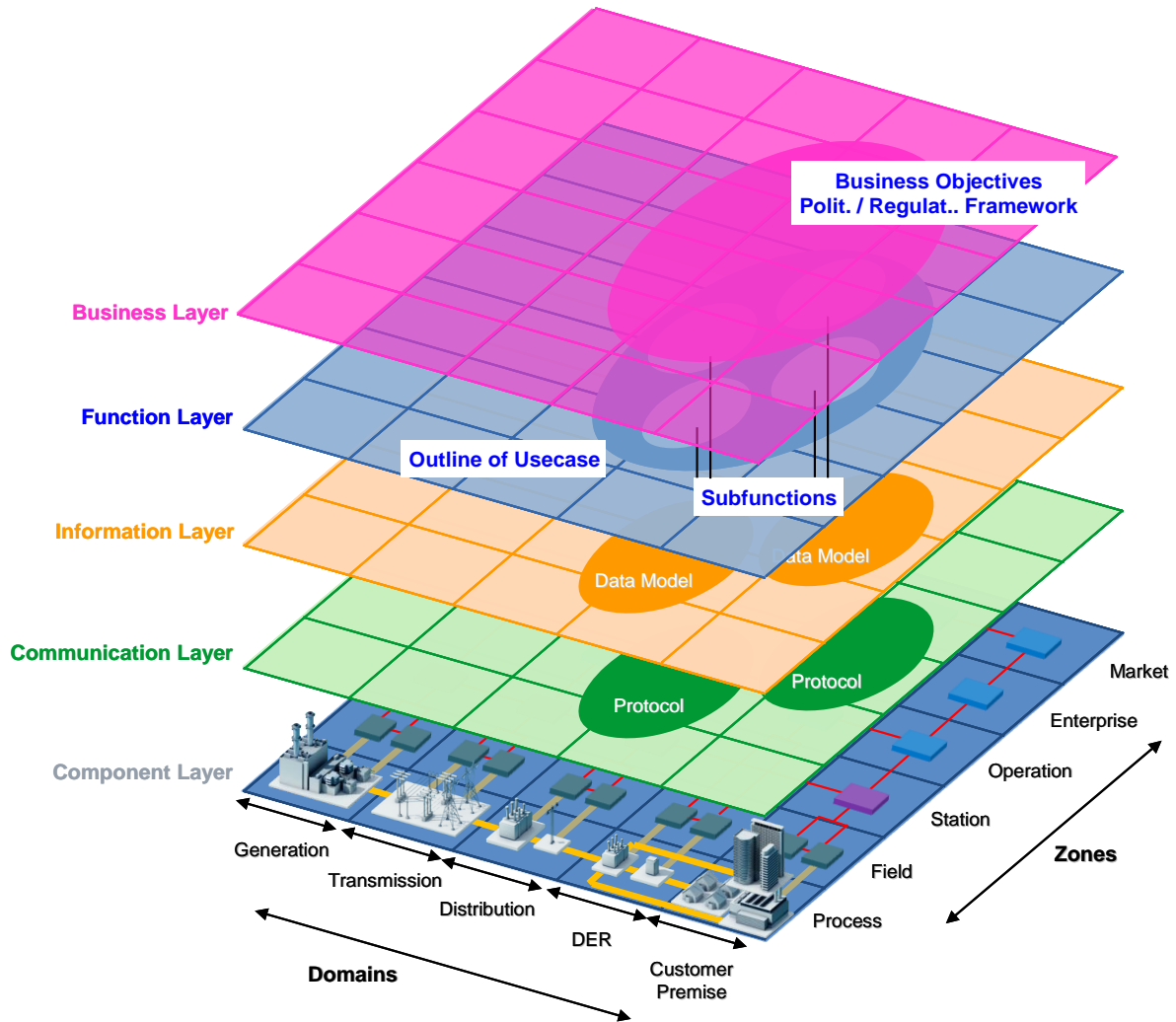

**Figure 3 – Smart Grid Architecture Model (SGAM)** [Source: SG-CG/M490/C]

The working group “First set of standards” (SG-CG/FSS) is working with an approach centered around breaking down the Smart Grid into systems [22]. In this approach use cases are used to describe the functionality of such systems. Actors should thereby be considered as linking the reference architecture on one hand (e.g. as components within the architecture or the users/roles of these components) and on the other hand with the system approach.

Furthermore the WG “Smart Grid Information Security” (SG-CG/SGIS) within the SG-CG also harnesses the use cases outlined in this document for the purpose of risk & threat analysis and for the assessment of proposed SGIS methods [24].

As such the work of the different working groups of the SG-CG is interlinked.

In a top down approach use cases are developed based on business cases/requirements<sup>1</sup> and / or a legal framework. A business case would reveal the legal, social, financial or environmental basis for a use case. However, the description of business cases/requirements was not a specific element of this work as use cases were only used to support standardization whereas business cases are relevant in an enterprise context. Nevertheless, in the descriptions of the use cases in the field “Scope and Objective” the general motivation behind each of the use cases has been outlined and therefore may only represent a general

<sup>1</sup> A business case is defined in the SG-CG/RA related to the business layer, as well as in [1]

business case. In a bottom up approach existing lower level use cases or functional possibilities of devices enable or support new business cases/requirements (refer to Figure 6).

In addition to the business cases/requirements the review and analysis of the collected use cases led to conceptual descriptions outlining the general ideas of clusters of use cases. These were roughly grouped as use cases clusters and high level use cases, which essentially describe the general functionality that might be realized in different systems and architectures (e.g. central or decentralized function), and primary use cases. As such, primary use cases are specializations of the high level use case and which are detailed enough to be mapped onto a specific architecture. However, one high level use case might comprise of several possible primary use cases (refer to chapter 6.5.3). Examples of generic use cases and clusters are provided in the UCMR.

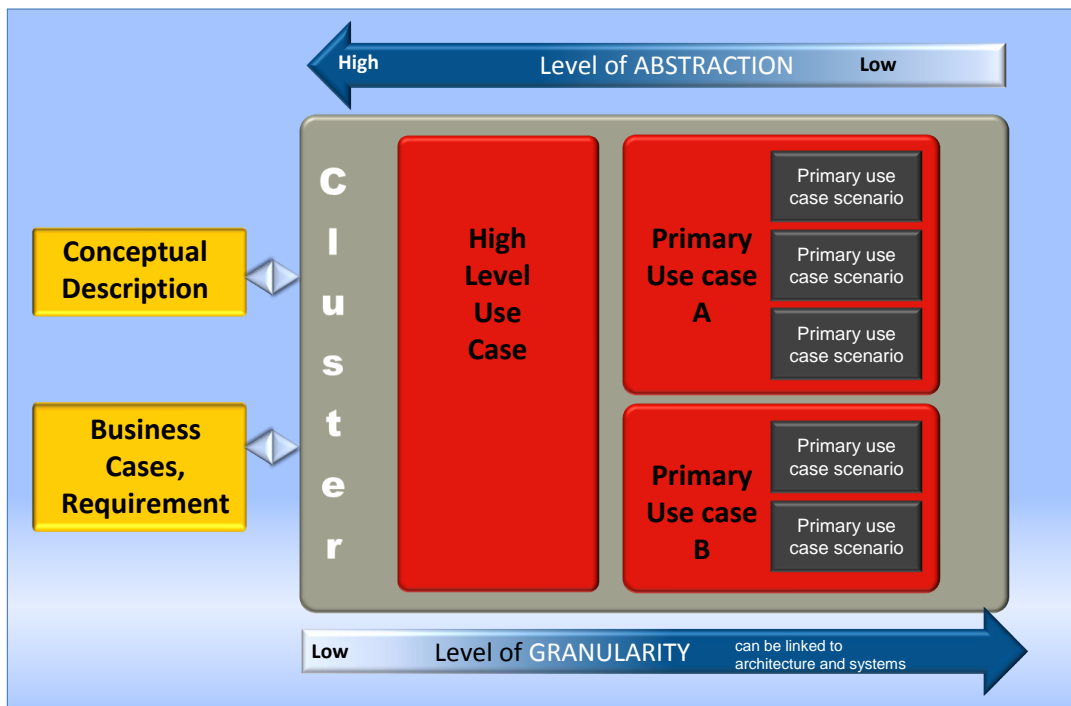

**Figure 4 – Use case structure (based on [8])**

Based on the structure described above, intermediate processes have been developed for the handling of use cases within a standardization organization. The processes are based on the developed Use Cases Management Repository (UCMR), an online database for use cases as collaborative platform for the description and discussion of use cases crossing various sectors. Recommendations for intermediate and later sustainable processes in standardization development organizations (SDO) have been proposed in this document (chapter 6.6).

The issues generating the greatest discussion with respect to the deployment of Smart Grids, include flexibility (demand response, DR, and markets) and smart charging, which are subsequently described in detail via conceptual models (found in Chapter 8). Moreover, conceptual models are worked out in generic use cases (chapter 9), a functional architecture and a suggestion for the inclusion of information security requirements based on the SGIS toolbox. Several other generic use cases in the field of distribution management are also described these include: FLIR (Fault Location, Identification, Restoration), VVO (Volt VAR Optimization), Forecast, Microgrid Management, Grid Monitoring for example.

Please note that use cases are not the magic bullets. The use case methodology should be seen as being part of a chain of necessary steps towards interoperable solutions. Related to standardization, technology



tracking and reference architecture are also needed as basis for concrete standardization work like the definition of data models, interfaces, protocols etc.

## 6 Use case methodology in standardization

### 6.1 Introduction

Through the mandate M/490, the European Commission requested the collection, analysis and harmonization of use cases as well as the establishment of a use case management process.

“A first set of Use Case management will be operational 9 months upon acceptance of the mandate. Hosting and processes will be in place. Further tasks to be performed according to the first steps are:

- To collect and harmonize use cases
- To map use cases with standards as a source for the definition of future standards
- ...” [11]

With respect to the scope of the M/490, the following remark is included:

*“Building, Industry, Appliances and Home automation are out of the scope of this mandate; however, their interfaces with the Smart Grid and related services have to be treated under this mandate.”*

In order to define these interfaces however, use cases in the smart home area have been taken into account without going into details.

NOTE Use cases focusing on Smart Metering are considered in the Smart Metering Coordination Group [8]. Use cases focusing on privacy/security functionalities are provided and maintained by the SG-CG/SGIS (Smart Grid Information Security). Further use cases had been developed by SG-CG/RA and SG-CG/FSS. All generic use cases are / will be included in the UCMR.

### 6.2 Background of use case method

The concept of use cases originates from software engineering and the main focus is on the description of general functionalities of systems under design and their environment. The description of use cases is independent of design specifics and allows the identification of requirements. They provide links to artefacts from different development viewpoints and due to that, they support a common understanding between experts from different domains and technical/IT experts who have to implement these functions. Moreover the concept of use cases is also supported by the Unified Modelling Language (UML) which provides use case diagrams to supports the description of use case ([15], [16], [32]).

Within the area of electrical and Smart Grids, the concept of use cases and their description in UML was adopted by Electric Power Research Institute (EPRI) and published as IEC PAS 62559 *Intelligrid Methodology for developing Requirements for Energy Systems* [1]. This IEC specification suggested a template for the description of use cases, which was the basis for a lot of use case descriptions worldwide. Depending on the aim of the use case description, this template had been varied quite often. The SG-CG/SP collected several modifications of the template and integrated them in a modified template which was used for the use case collection. The modified template can be seen as a further development of the original template while the general idea is kept. The ideas are provided to IEC / TC 8 where successfully a Committee Draft (CD) for an International Standard defining a use case template [9] has been provided.

The concept of the use cases description is meanwhile also introduced into other areas as well: e.g. use cases are described to check and develop the legal framework for energy laws to define new energy market design rules.

### 6.3 The standardization mandate of the European Commission M/490 “Smart Grids”

The mandate M/490 [11] demands use case management as one method to provide sustainable standardization processes. It should be in operation and first use cases should be collected and analyzed within nine month (target date 1 March 2012).

Quote

*“Sustainable standardization processes and collaborative tools to enable stakeholder interactions, .... and adapt them to new requirements based on gap analysis, while ensuring the fit to high level system constraints such as interoperability, security, and privacy, etc.”*

End quote

With this demand the European Commission has reflected discussions and emerging preferences from within Standards Development Organizations (SDOs) and in the Smart Grid community, that use cases are needed for the description of a complex system like the Smart Grid. Several committees are already using use cases for their internal work. IEC Strategic Group 3 “Smart Grids” (SG3) requires that TC 8 is designated as the coordinating committee for the further development of the existing use case method in order to adopt it to complement existing standardization processes and thereby collect use cases in the field of Smart Grid together with other TCs. IEC / TC 8 Ad hoc Group 4 (AHG 4) was coordinating the task and defined several domain core teams (DCT) and a subgroup “Method & Tools”. Meanwhile the task is handed over to the new working groups 5 “Methodology and Tools” and working group 6 “Generic Smart Grid Requirements”, both supported by experts of the SG-CG/SP in order to align with the results achieved so far. This aim aligns closely with the work of the SG-CG/SP and a close cooperation and exchange of experience and ideas is ensured in order to avoid conflicting double work.

Furthermore, not only does the mandate require the systematic collection of use cases for the Smart Grid, the previous report of the Joint Working Group of CEN, CENELEC and ETSI (June 2010) also echoes their importance stating and recommending that the SG-CG process should collect and “agree on a set of European use cases”.

### 6.4 Motivation of the use cases approach for standardization

The general objective of the SG-CG’s work on use cases is therefore to gather requirements of functionalities in a structured way. Based on these collected use cases existing ISO/IEC/ITU and CEN/CENELEC/ETSI standards can then be analyzed, if they are supporting these functionalities (use cases) or if further developments of standards to close identified gaps have to be initiated.

The following description lists further arguments why the use case approach is useful for standardization organizations (items 1-5).

#### 1. Use cases as collaborative platform

Use cases should provide the basis to capture Smart Grid requirements from different possible sources. The work on use case should lead to both: the means for defining technologies and an increasing common understanding and cooperation

- between experts, coming from different domains like grid, market and who provide the knowledge about the system and the requirements on the one hand, and ICT (Information and Communication Technologies) experts defining details for the IT and communication system on the other hand
- within a Technical Committee (TC) or Working Group (WG)
- between different TC’s and sectors

As the Smart Grid is a system of systems, which crosses a number of TC’s representing various domains and sectors (refer to the IEC / SG3 report [17]), use cases may serve as a collaborative method to provide the basis for a common understanding about new requirements and functions. If there are

validated versions of use cases, which are broadly accepted amongst the Smart Grid experts from different TC's, these use cases can serve as a basis for analysis by each TC. As such, based on further considerations like the mapping to a Smart Grid Reference Architecture (SGAM), new requirements may emerge which in turn lead to a modification of existing standards or the need for new standards (refer to [21] - [23]).

Considering the aim of the use case approach it is clear that such an approach adds value to the field of standardization. However, the acceptance process of use cases as generic, should be transparently supported by standardization processes and the result should be managed and maintained as one of the standardization deliverables. The acceptance will be of high importance for the following analysis and the development of standards based on the use cases. So the development of a process to generate accepted generic use cases provides advantages and adds value to the current work of the SG-CG/SP and the standardization activities when compared to a pure collection.

The collection of use cases within Europe, involving all Smart Grid stakeholders such as technical and national committees, Smart Grid R&D projects and associations, has provided the basis for further analysis and the suggested first set of generic use cases of the SG-CG/SP. The provided use cases represent a valuable synthesis of both the objectives and practical experience of the involved sectors (market relevance).

Furthermore the provision of use cases for standardization sourced from a diverse constellation of stakeholders will serve as a platform for knowledge management, as the use cases considered in standardization will be maintained, in spite of e.g. use cases in the R&D projects after the end of the project.

## 2. Use cases approach for the development of new standards

Use Cases are the basis for the definition of requirements in different standardization fields (gap analysis).

Use cases provide input for the following areas of standardization:

- Interoperability / communication

As the concept originally was developed by the ICT industry, the main focus of use cases in standardization is the ICT interoperability of the whole system of the Smart Grid including subsystems<sup>2</sup>, installations or products connected to the Smart Grid, while the system is crossing a lot of different domains and sectors.

A close link to actors and architecture within the overall system is therefore necessary for interoperability while use cases are required to identify or confirm architecture and actors in this system. On the other hand, use cases are based on a basic understanding of actors and architecture; so the development of use cases, actors and architecture has to be an iterative process. One example is the development of the flexibility conceptual model (chapter 8) which was based on the collected use cases.

Additionally use cases are also supporting the definition of interfaces, data models and data objects as well as the protocols needed (refer to the Smart Grid Architecture Model (SGAM) and the definition of interoperability of the SG-CG/RA [23]).

- IT Security, privacy and data protection

Use cases are the basis for a risk and threat analysis in order to define requirements for the IT security, privacy and data protection [24].

- Safety

---

<sup>2</sup> please note the current scope of the mandated work

But use cases are not only needed for the ICT part of the system. These use cases provide a helpful basis from which to conduct risk analysis in order to define requirements for the safety of the system itself, subsystems, installations or products connected to the Smart Grid (e.g. related to risk analysis for functional safety or for Electromechanical Compatibility (EMC)).

– Terminology

Furthermore harnessing a use cases based approach also drives the emergence of new terms and definitions which can be used within the standardization of terminology (e.g. for the International Electrotechnical Vocabulary of IEC (IEV, [www.electropedia.org](http://www.electropedia.org)). Setting-up a library of use cases, cross-cutting many technology domains is only efficient when a frame of consistency has been defined. Such frame includes:

- Common list of actors and their exact role (refer to annex A)
- Common words (functions, data, services, ...)

3. Use case approach for guidance through existing standard framework

The JWG Report [13] [14] as well as the report from SG-CG/FSS [23] illustrates the significant contribution which existing standards are providing already today for the Smart Grid. This result conflicts with the general perception in the public which is requiring “Smart Grid standards”. The use case collection in combination with the work on the SGAM and especially [23] can provide a guidance to standardization for experts of different sectors and the public.

4. Standard profiles<sup>3</sup>

Use Cases might be used to define so called standard profiles. Here a standard profile is defined as a subset of existing standards which reduces alternatives in the existing and usually more generic standards in order to define clear interoperability for specific tasks, interfaces or actors. These standard profiles can be related to the functionality of specific actors or interfaces (e.g. for the connection of grid users like DER) which are described in the use cases.

5. Test of interoperability<sup>3</sup>

Use cases can be used in order to provide test cases for the check of functionality and communication (interoperability).

## 6.5 Use case systematics and definitions

### 6.5.1 Use cases template

The template is a structured description in a given format which helps to describe, compare and administrate use cases. It serves as link between the domain experts, which are interested in a function, and the IT specialists, responsible for the realization, using the use cases for their further engineering process (therefore the Use Cases Management Repository (UCMR) provides an UML export).

The template mainly contains the following information:

- Administrative information (e.g. version management)
- Description of the function(s)

e.g. general narrative description, pictures, detailed description within the scenarios and activities

---

<sup>3</sup> not part of the current activities of the SG-CG/SP

- The system under discussion (subject) and its design scope
- Actors linked to the function and the activities (activity = one step of the detailed step-by-step description)
- Extended information for classification of the use cases

As of today there are several key items of information which are used to classify, group or map use cases in order to analyze one or various use cases according to different needs of the users, already included in the aforementioned template. In beginning with the use case approach and defining an overall process within the SG-CG including use cases it soon emerged that further information and system mapping would likely be linked to the final initial set of defined use cases (e.g. a mapping to systems or the SGAM). Indeed, it was acknowledged that any subsequent mapping might be integrated into the template in future. However the template is considered already today as fairly complex, so that external classifications can be better linked directly to the use case database of the use cases management repository (see below).

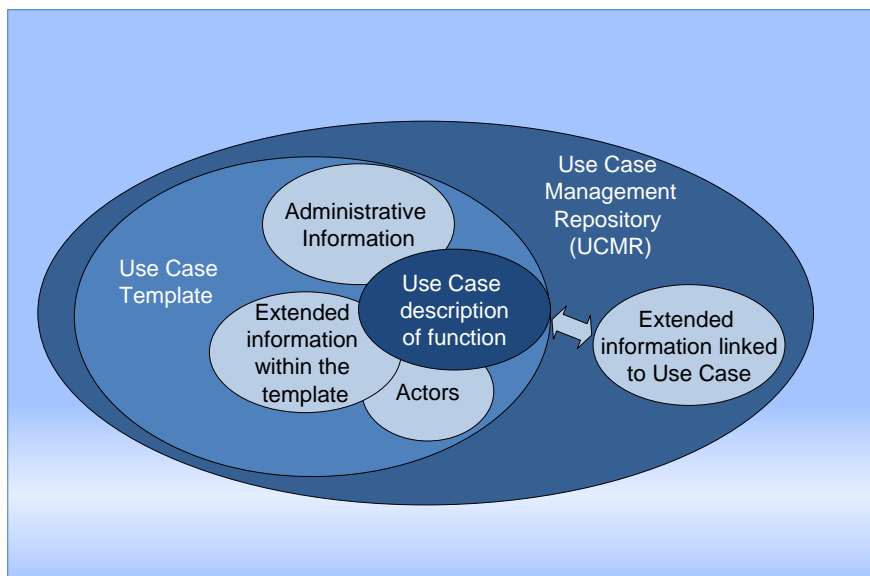

**Figure 5 – Different information related to use cases**

In order to harmonize use cases in standardization it was seen as essential that some information is standardized for all use cases: the template itself, the actors (refer to the actor list), technical or organizational requirements in the activities, pre-defined selections for some fields of the template.

Further details about the template are provided in [9].

### 6.5.2 Multidimensional classification of use cases to allow different views

Even applying the proposed structure, it can be expected that the complexity of the gathered information will grow with the number of described use cases as well as with the extended information linked to use cases. Therefore, an improved handling and an increased usability for the users of the use cases is needed. As a first step a specialized database, reflecting the template structure, including a customized user front end was introduced, the so called Use Case Management Repository (UCMR, refer to chapter 10). The UCMR allows the writer of a use case to start with filling the minimum set of mandatory information of the template and add later on additionally needed information. Selection boxes or drag & drop of predefined content (e.g. actor list) will help him. The UCMR supports a central administration of all use cases and allows a collaborative work on writing use cases.



Further steps to reduce the complexity can be achieved by providing information relation (predefined reports / views). So the user only receives that information he is interested in at this point in time.

The following provide some examples of different views or perspectives which might be added to the UCMR according to the needs of the user.

Use cases <-> related to:

- Actors (systems, market roles, etc.)
- Systems
- Smart Grid services defined by the EC task force Smart Grid and its Expert Group 1
- Technical Committees
- Clusters
- linked other use cases (<<contains>> relation of UML)
- SGAM (Domain(s), Zone(s))
- technical or organizational requirements (e.g. requirements regarding security)

But also combinations like

- actors to systems
- HL-UC to PUC
- or further examples

Advantages:

- In principle, there is no right or wrong perspective when analyzing use cases. Different perspectives are possible.
- The DB approach supports search functions in the repository; e.g. if the user is only interested in those use cases containing a specific actor.
- The analysis of use cases is supported.

Recommendation:

The functionality to get a report for specific relations has to be integrated into the UCMR in future versions.

### **6.5.3 Use case structure / definitions of different use cases types**

One important example for a classification criteria is the abstraction level which is defined by the detail of the description and the task of the use case. For the Smart Grid, use cases on different levels are expected so that the following rough structure had been suggested. Practical examples of these theoretical considerations are given in chapter 9 (generic use cases).

The following description of use cases types and related artefacts is related to Figure 4 and Figure 6.

- The use case approach is a good methodology for the formal description of different types of functions, processes or systems. From a general perspective, use cases could deal with business processes and business functions according to the chapter "business architecture" described in the

report of SG-CG/RA. The following elements, also used in use cases, can be mapped to the business and/or function layer of the SGAM:

- Roles & actors
- Functions
- Business services, business processes (or business process model)

The business processes and related business functions (the How/What) should be described with the use case methodology. In addition, the *Business Requirements and Business Cases* as input for the formal description of the business processes and business functions, should describe the motivation (the Why) and lead to a prioritization according to the created value. In the methodology proposed by SG-CG/SP, business cases are a part of the template of the use cases: the field “objectives” often includes also a rough motivation for the use case itself. Detailed business cases are often worked out company internal.

At a lower level, use cases deal more with technical functions that are involved in the realization of business functions and processes.

- *Conceptual description* provides an overview or background for a cluster of use cases; e.g. the flexibility or smart charging concept is described in the following chapters in order to provide an introduction into the related use cases. Here the conceptual models are resulting from the analysis of use cases and the development of the generic use cases (see below). The conceptual description reflects the iterative work of describing use cases, analyzing them, detail them further and link them to architectures, actors and systems.

Example: flexibility concept refer to chapter 8.2

- **Cluster** represents a group of use cases

Example: Smart Charging (WGSP-1xxx)

- **Use case** describes functions of a system in a technology-neutral way. It identifies participating actors which can for instance be other systems or human actors which are playing a role within a use case. Use cases can be specified on different levels of granularity and are according to their level of technological abstraction and granularity either described as High Level Use Case (HL-UC) or Primary Use Case (PUC).
- **High level use case (HL-UC)** describes the general idea of a function together with generic actors. Possibly the HL-UC can be realized in different ways, so that the HL-UC cannot be mapped to a specific system or architecture.

Example: Fault Location, Isolation, Restoration (FLIR) in general

- **Primary use case (PUC)** is a use case implemented in a specific system characterized by a defined boundary (i.e. it can be mapped on a defined architecture). This means that a higher level abstract use case might be broken down into one or more implementation possibilities, called specializations. These use cases can be mapped to a proposed architecture (SGAM).

Example: Different FLIR use cases implementing the basic functionality within a central (WGSP-0100 FLIR, refer to UCMR) or decentralized architecture or which are related to different network topologies.

- **Scenarios** define different routes within one PUC according to different trigger signals (within the template).

Example: Scenarios describe normal, alternative or error sequences.

- **Steps** used to describe activities within a scenario in a sequential order (refer to the step-by-step analysis of the use case template)

Examples: Refer to generic use case like WGSP-0100 FLIR or WGSP-2110/2120 (Providing Flexibility) (refer to UCMR)

- *Secondary use case* - Within the SM-CG the term *secondary use case* is used to describe core functionalities that are used by multiple PUC's. It seems that this is not needed for the current abstraction level of the SG-CG/SP. In future this concept might be followed when the primary use cases are further detailed (e.g. by experts in technical committees).
- *Specialized use case* - The term was suggested to define a difference between primary use cases which are technology neutral and specialized use cases which are already describing specific technologies like a specific protocol (e.g. FLIR with IEC 61850 or flexibility use cases within a house using one or more home automation standards). Same as for the secondary use cases these use case type will not be followed by the SG-CG/SP, but might be used by the relevant TC's when further detailing GUC's.

NOTE There might be alternative possibilities inside a proposed use case. This alternatives can be described by alternative use case, alternative scenarios inside the use cases or it can be mentioned inside the use case that some steps are optional.

Moreover use cases can be classified according to their applicability in regional or business contexts as generic or individual:

- **Generic use case (GUC)** - Use cases will be called generic, when their description is broadly accepted in standardization and not project or technology specific. They should cover/summarize/ conclude on various approaches answering the request for use case harmonization which means that double use cases should be avoided. The GUC can be used for further work inside standardization (e.g. mapping to architecture, development of standards or test use cases). GUC might be described on a high or more detailed level, implying different systems design scope. In future new GUC should fit into an already given framework with existing generic use cases in order to keep the system consistent. If possible, new GUC should explain the relation to the existing set of generic use cases.

Generic use cases are currently considered to be an informative standardization product, not necessarily leading a normative description (refer to chapter 6.6).

According to the task of the Mandate M/490 the SG-CG/SP started a harmonization of the collected use case. In the following chapters the concept of generic use cases (GUC) is used to differentiate the GUC from the collected use cases of individual stakeholders. So the GUC's are a result of harmonizing use cases, but mainly based on the information provided by the collected use cases.

During the work on the mandate M/490 and the different versions of this report also the other working groups of the SG-CG provided GUC's.

- **Individual use case** - In real projects later on, a company might combine generic use cases, developing them further to individual ones, together with own, individual, company-specific use cases which are belonging to its knowledge base and its business cases (refer to Figure 6 – right side).

In a top down approach primary use cases are developed based on high level use cases. From each use case a lower level of more detailed use cases can be developed (refer to Figure 6 left side). In a bottom up approach basic use cases can be combined with other use cases to new high level use cases. One single lower level use case can serve for different high level use case. In the Use Case Management Repository (UCMR) the interrelation of use cases can be modeled in a tree structure<sup>4</sup>.

---

<sup>4</sup> as described in UML as <<contains>>

**Recommendation:**

Especially for use cases like Demand Side Management and Demand Response (flexibility concept) where several actors and market roles are involved and therefore various interfaces exist, accepted generic use cases among those market roles are essential. So the definition of generic use cases can be seen as typical standardization task.

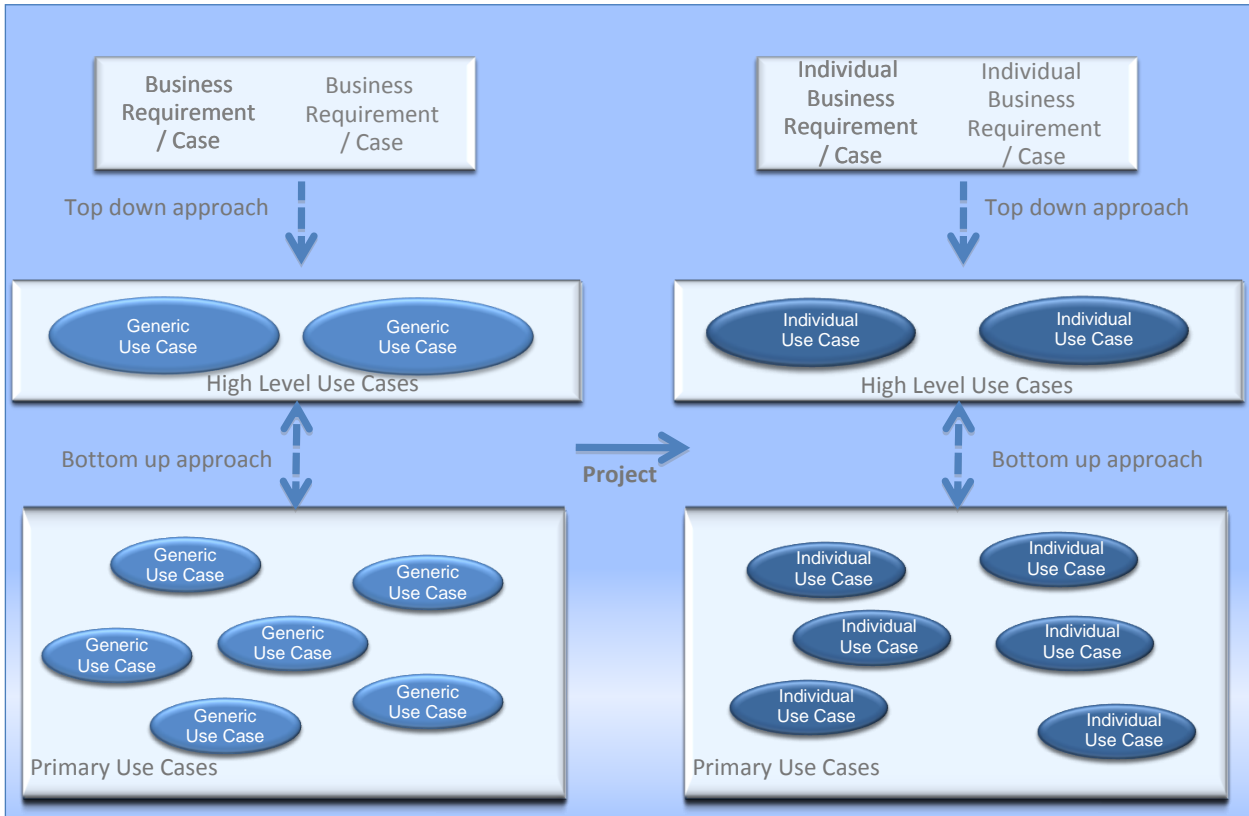

**Figure 6 – Relation of high level use cases and primary use case as well as generic use cases and individual use cases**

Use case as network

The above structure is seen as first attempt to group and sort use cases. Further possibilities are described in the following chapter. In general the use case hierarchy cannot be followed strictly as i.e. a PUC can be related to other PUC's or one PUC might serve several high level use cases. Being precise the relation of use cases to each other has to be shown in a network/graph structure. Within the use case repository relations of use cases can be defined and the network can be graphically evaluated in UML software tools.

**6.5.4 Use cases and systems**

Another example representing a mapping of use cases to criteria outside of the template is introduced by the report of the SG-CG/FSS. The report is structured by systems which are defined as follows:

**System<sup>5</sup>**

---

<sup>5</sup> taken from SG-CG/M490/B

- a typical industry arrangement of components and systems, based on a single architecture, serving a specific set of use cases
- may be interfaced to other systems (appearing then as "system actors", when describing the corresponding use case)
- hosts use case (an abstract HL-UC can be related to various systems)

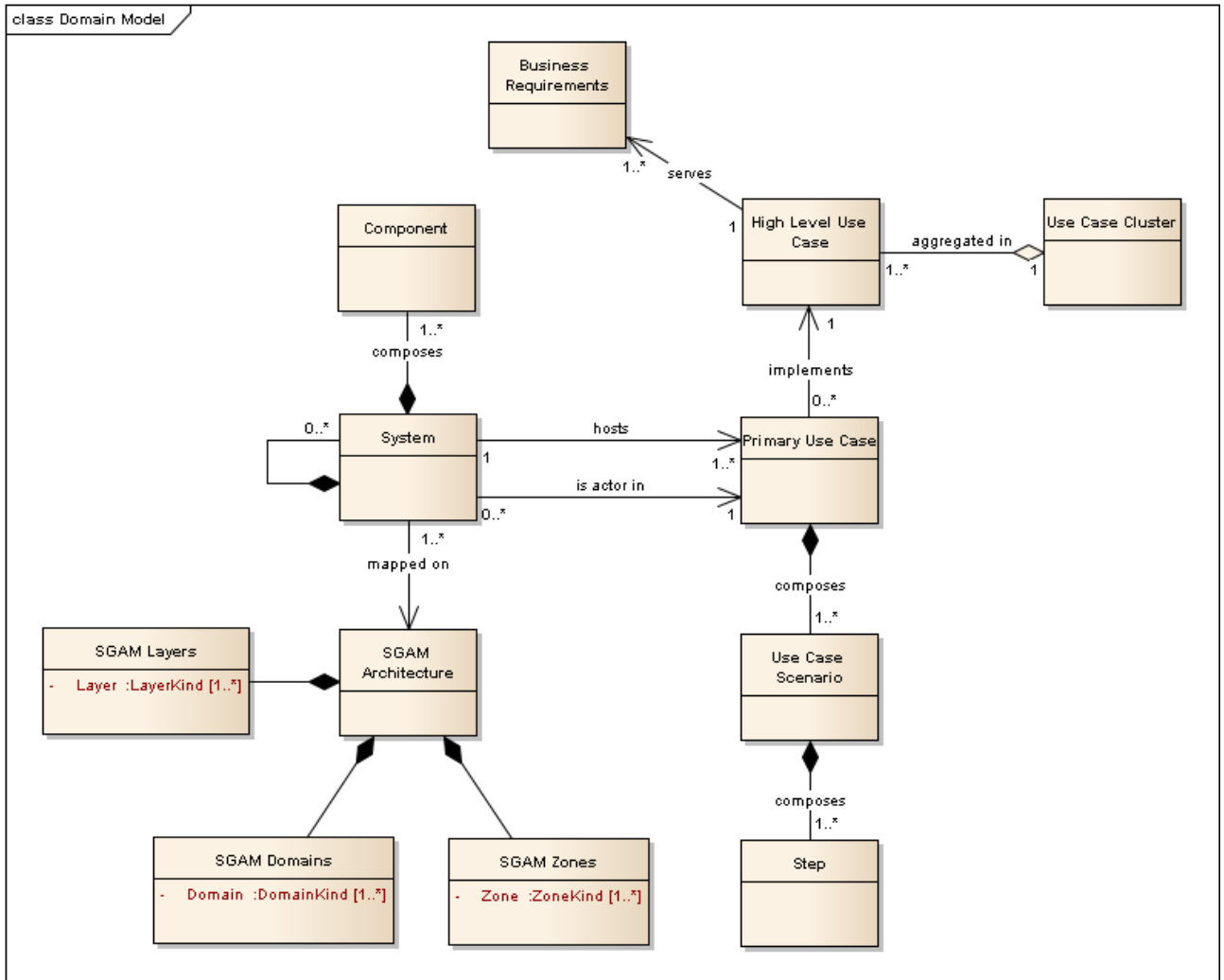

Figure 7 – Relation of use cases, systems, and SGAM

## 6.6 Use case processes

In relation to the use case approach different processes have to be described, acknowledging the difference between them:

1. General process and methodology of defining use case in relation to the overall process which is under development in the SG-CG

The general process is described in [21]. In the following chapter this general process is reviewed under a use cases perspective.

## 2. Current processes

As an agreed and validated process for the use case management inside standardization is not available, the current informal process had been developed in the SG-CG/SP under acknowledgement of the SG-CG.

- Steps taken in the SG-CG/SP until today
- Recommended intermediate processes and next steps until a sustainable general work process is installed

## 3. Suggestions for a sustainable use case process in standard developing organizations (SDO)

### 6.7 General process and methodology of defining use cases in relation to the overall process

In general the following steps are needed for the use case approach in standardization:

#### 1. Providing use cases

Different sources might suggest use cases to standardization. As these use cases should be considered as market needs, they might arise from internal sources of the standardization organization (e.g. Technical Committees) or from external stakeholders such as via R&D projects, regulation, legislation, or cooperation partners like associations.

Recommendation: Ideally the requirements are directly formulated in the given use case template – also from external stakeholders. Not all fields and details need to be filled in the first step, but this roughly filled use case<sup>6</sup> can still be used inside standardization for further evaluation.

#### 2. Discussing and harmonizing (different) use cases in order to generate broadly accepted GUC's -> 3.

During the evaluation process further information is provided into the template. According to the suggested transparent and open process different stakeholders (e.g. different TC's) might participate in the evaluation process and provide information in one common use case template. The external source can follow up the detailing and can comment on it. So the use case template and the related collaborative platform (UCMR) acts as originally intended as link between domain experts and system specialists. In case variations of use cases with same functions were provided, they have to be reviewed and combined to a suggestion for one common generic use cases.

#### 3. Generic use cases (GUC), which are used for further analysis in relation to standardization

The following steps are related to use cases for ICT and interoperability issues exceeding the pure use case approach:

#### 4. Analysis: according to the overall process [21][22] a GUC, which is specific enough (Primary Use Case), is mapped to

- a. the reference architecture (here: Smart Grid Architecture Model, SGAM)

The different layers of the architecture are providing lists of standards applicable for the relevant use case.

---

<sup>6</sup> during the use case collection phase a short version of the template which was broadly used

In fact, current examples of the SG-CG/M490/B [22] and the examples around the concept of flexibility within this report are suggesting that there is a strong link between systems which are described in an architecture and primary use cases using this architecture and its components / actors. In this case several use cases are related to one system architecture.

b. to information security requirements

Based on the analysis of the use cases risks can be evaluated and according to the risk level different technical and organizational requirements are suggested (see example below).

As recursive process this step might lead again to an update of the GUC (requirements, additional information like actors).

5. If a gap in standardization is identified, the missing standards lead to a new item in the work program for standardization (SG-CG/FSS, [23]).
6. Exceeding the current use case approach further steps to ensure interoperability are needed (profiling of standards, interoperability tests using test cases which might be generated out of the generic use cases).

## 6.8 The role of use cases in evaluating standards

The process described above is represented in Figure 8 below. It shows that the use cases are a basis for identification, evaluation and maintenance of Smart Grid standards.

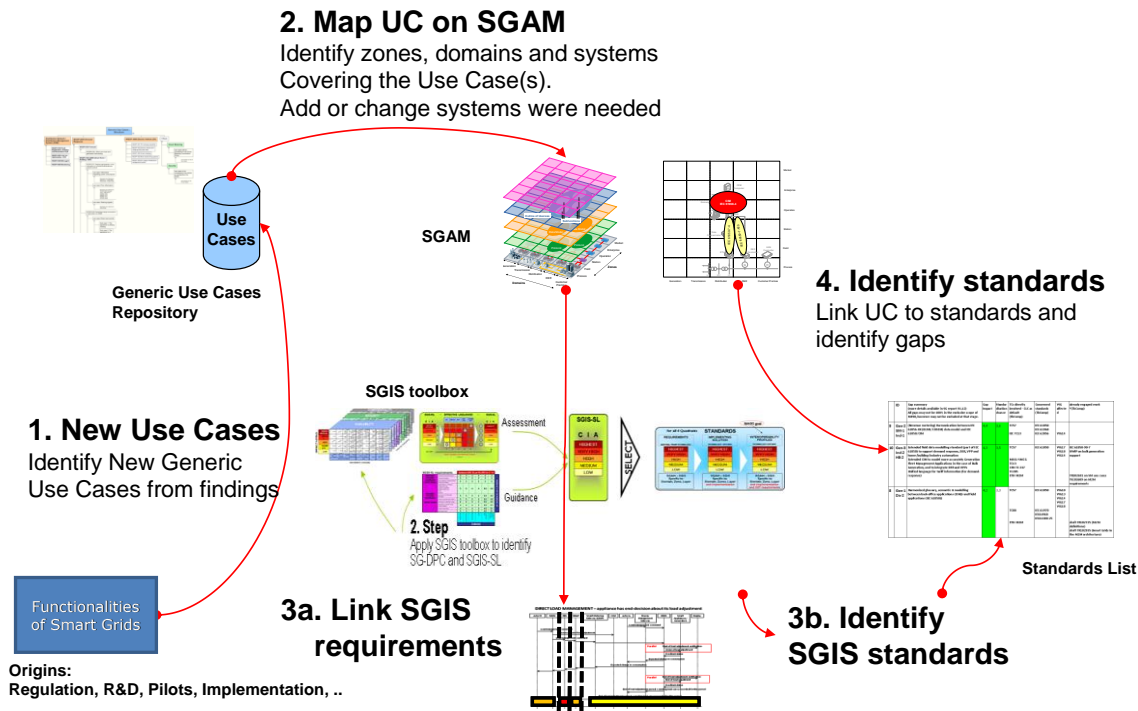

**Figure 8 – The maintenance of a list of Smart Grid standards including information security (based on [21][24])**

The use cases comprises functional and technical requirements for Smart Grid standards. According to step 4 "Analysis" above use cases are mapped on the Smart Grid Architecture Model (comprising definitions of domains, zones and systems). Especially the detailed activities of the step-by-step description of the use cases show the interaction of system components among each other and which can be linked in the architecture.

Figure 9 shows an example of the mapping of a use case, taken from one of the scenarios from the generic use case WGSP-2111, on the zones of the SGAM. The system components are those from the "Flexibility System" which are mapped to the zones of the SGAM (Meter Data Management System, Head End System, Neighbourhood Network Access Point, Local Network Access Point, Consumer Energy Management System, etc.; refer to chapter 8.2.1.4).



### Price & environmental information

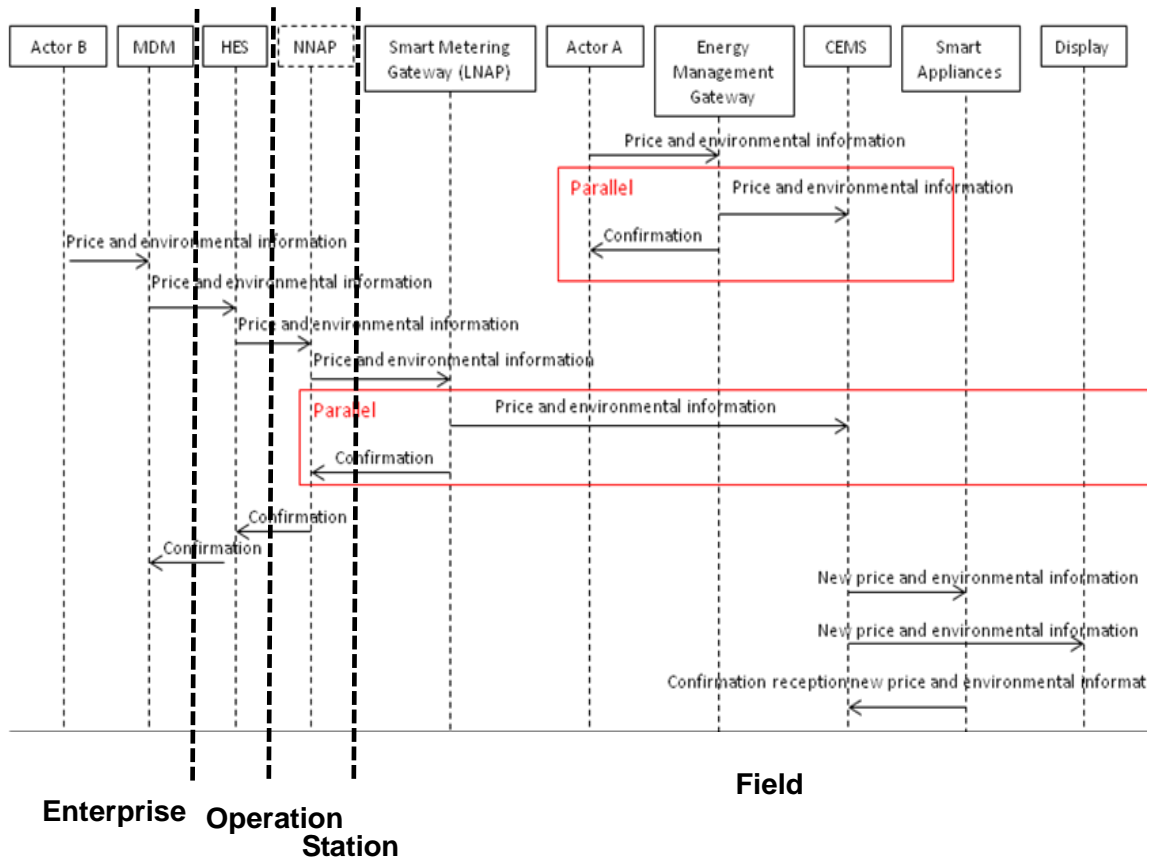

**Figure 9 – Mapping on SGAM zones**

The zones covered by these use cases are: enterprise, operation, station and field.

After mapping a use case on the SGAM it will be possible to perform a risk analysis on the use case, because the risks are depending on the concerning domains and zones.

For every use case, zone and data type a risk analysis must be performed based on the toolbox developed by the Working Group Smart Grid Information Security (SG-CG/SGIS) [24].

Figure 10 shows a table that is used to define the risk level.

<b>RISK IMPACT LEVELS</b>	<b>HIGHLY CRITICAL</b>	regional grids from 10GW	from 10 GW/h	from 50% population in a country or from 25% in several countries	international critical infrastructures affected	not defined	company closure or collateral disruptions	direct and collateral deaths	permanent loss of trust affecting all corporation	>50% EBITDA
	<b>CRITICAL</b>	national grids from 1 GW to 10GW	from 1 GW/h to 10GW/h	from 25% to 50% population size affected	national critical infrastructures affected	not defined	temporary disruption of activities	collateral deaths	permanent loss of trust in a country	<50% EBITDA
	<b>HIGH</b>	city grids from 100MW to 1GW	from 100MW/h to 1GW/h	from 10% to 25% population size affected	essential infrastructures affected	unauthorized disclosure or modification of sensitive data	finances from 10% of EBITDA	direct deaths	temporary loss of trust in a country	<33% EBITDA
	<b>MEDIUM</b>	neighborhood grids from 1MW to 100MW	from 1MW/h to 100MW/h	from 2% to 10% population size affected	complimentary infrastructures affected	unauthorized disclosure or modification of personal data	finances up to 10% of EBITDA	seriously injured or incapacity	temporary and local loss or trust	<10% EBITDA
	<b>LOW</b>	home or building networks under 1 MW	under 1MW/h	under 2% population size affected in a country	no complimentary infrastructures	no personal nor sensitive data involved	warnings	minor accidents	short time & scope (warnings)	<1% EBITDA
		Energy supply (Watt)	Energy flow (Watt/hour)	Population	Infrastructures	Data protection	other laws & regulations	HUMAN	REPUTATION	FINANCIAL
OPERATIONAL (availability)					LEGAL					
<b>MEASUREMENT CATEGORIES</b>										

**Figure 10 – Definition of the risk impact level (source: SG-CG/M490/D)**

The SGIS toolbox [24] describes how the risk level combined with a probability analysis will result in a security level from 1-5. Then it is explained how the security levels are linked to security requirements. So finally this procedure results in the identification of security requirements per use case.

After mapping a use case to the SGAM and linking security requirements, the standards to support this use case can be linked to the use case. This final step also links the functional and technical requirements to the standards and a gap analysis on these standards can be performed.

## 6.9 Current processes

### 6.9.1 Steps taken by the SG-CG/SP until today

The general description of the work progress of the SG-CG/SP is described in Annex B. In short the current intermediate process followed these steps:

1. Definition of methodology (especially defining the template)
2. Information of stakeholders and collection of use cases
3. Analyzing of received use cases

The results of the collection and the analysis are presented in chapter 7

4. Summarizing the ideas into generic use cases and conceptual descriptions

Chapter 8 and 9

5. Discussion of generic use cases (GUC) and conceptual descriptions -> updating of documents

Comments to the previous versions had been received and the main chapters had been discussed in two workshops with stakeholders (May 2012).

6. Suggestions for further GUC's by the other SG-CG working groups (mainly SG-CG/FSS and SG-CG/SGIS, SG-CG/RA)

## 6.9.2 Intermediate process and next steps until a sustainable general work progress is installed

As long as there is no validated standardization process by the European Standards Organization's (ESO's) or recognized International SDO's, following draft principles are followed for the time being in order to ensure continuity and further implementation of the new approach and the new tools.

Recommendations:

### - Relation with Technical Committees

After acceptance of the general process and the use case approach it is considered as most important to involve the technical committees of the ESO's. The SG-CG/SP is only a temporarily working group. Therefore it is quite important to get support from the TC's which are expected to take over the responsibility for single generic use cases or groups of use cases (e.g. a cluster). Within this report a first suggestion is provided which TC should take the responsibility for which GUC. These TC's are called Coordinating TC's. As a lot of use cases are crossing the interest of various TC's further TC's are suggested as "involved". TC's might suggest themselves as involved<sup>7</sup>.

Refer to Table 3 – Mapping of generic use cases to involved Technical Committees.

The coordinating TC's and the involved TC's are detailing the GUC itself and may decide about further GUC on a detailed level (if needed). But all suggestions for new generic use cases should be linked as far as possible to the existing ones in order to keep them consistent.

### - UCMR

- All use cases shall be described and maintained in the Use Case Management Repository (UCMR) as central use case database for the Smart Grid use cases of the Smart Grid Coordination Group.
- The UCMR as well as the current use cases will be maintained until a final decision about an European use case repository is taken. Use cases collected and detailed in the meantime can be transferred, in case the current tool will be changed in future. Although this is not assumed yet, the export functions of the UCMR reduces the risk of lost efforts and allows now a quick start of use case descriptions.
- The UCMR, its use cases and the use case approach has been suggested also in the international standardization in order to ensure a maximum of harmonization worldwide.
- The UCMR with the suggested GUC is public with a read-only access for the time being.
- Members of technical committees of the ESO's can apply for an access with write permission. Recommendation: A tracking of changes should be realized.
- The collected use cases are available for technical committees as further knowledge base (not public).
- TC's can request a workspace in the UCMR for their use case development.

### - Suggesting a new GUC or Actor

- New generic use cases shall be suggested in the UCMR directly.
- Technical committees or external stakeholders may suggest new use cases in the given template or directly in the UCMR (preferred).

---

<sup>7</sup> first contacts shows interest of TC's

- New GUC's suggested by a specific committee which can be clearly related to this work item can be included directly (e.g. Smart Metering use cases by the SM-CG).
- For the time being suggestions for new GUC's or actors are reviewed by the SG-CG/SP or its successor organization after the end / during iteration of the mandate.
- The proposer of the new use case should check, if the use case is already available or similarly available. In this case he is requested to contribute to the existing GUC instead of providing a new use case.

By providing a new use case the author considers<sup>8</sup>:

- the criteria for GUC (e.g. not project specific, ...)
  - using the Use Case Management Repository (UCMR),
  - indicating the use case as NEW in the title,
  - accepting the exploitation rights agreement needed for standardization,
  - explains links to existing GUC
- If use cases are duplicated, they should be described explicitly as alternatives to the already existing ones and should be related to them. This might be needed for instance, if a generic use case on European level will be modified in order to match it to national specific circumstances.
  - After review the new GUC will be opened for discussion and further suggestions by the standardization community on the collaborative platform (UCMR). Recommendation: TC's considered to be relevant should be informed about the new use case, so that the TC's can provide further input, comments or changes.
  - After a time period, which has to be defined, the discussion will be ended and the use case is considered as broadly accepted. In the UCMR the GUC will be shifted to a workspace called FINAL. As the use case process is currently not part of the official standardization processes there will be no official voting. A generic use case in the workspace FINAL can be seen as recommendation for standardization work in the technical committees.
- Recommendation: The method should be suggested and tested also for other issues not directly related to Smart Grid (currently under discussion for E-Mobility working groups).

### 6.9.3 Suggestions for Standard Development Organizations (SDO) relevant for a sustainable use case approach

#### 6.9.3.1 Background

This chapter of the report addressing parts of deliverable no. 3 of mandate M/490 is specified as:

*"Sustainable standardization processes and collaborative tools to enable stakeholder interactions, to improve the two above and adapt them to new requirements based on gap analysis, while ensuring the fit to high level system constraints such as interoperability, security, and privacy, etc."*

As a further background and motivation, one of the recommendations from CEN/CENELEC/ETSI Joint Working Group on Standards for Smart Grids is to [13], [14]:

- *Agree on a European set of use cases*
- *Establish a single repository of use cases to systematically identify existing and future standardization needs.*

---

<sup>8</sup> At the beginning the WG SP may provide support for stakeholder describing use cases, if required.

These expectations had been worked out by the processes and steps taken as described before. Nevertheless, the process of managing use cases within standardization has to be transferred from the intermediate solution to a solution which is fully implemented in the SDO's.

### **6.9.3.2 Introduction**

The following basic requirements should be fulfilled:

- Maintaining a tool/database available for all stakeholders
- Design of a sustainable work process to secure adequate content and quality of the database.

Considering the already realized concept and the existing standardization processes a mixture of both has to be established:

1. Providing the possibility for discussions and common developments of generic use cases on a collaborative platform like the UCMR (as described before)
2. Validating the results with an official procedure (suggestions are provided in the following subchapters)
3. Publishing the official results, recommended with a database access

However another basic question is raised and a suggestion is made: A solution has to be provided for the fact that the broad variety of possible use cases needs a global coordination and ensuring the cross-cutting nature of the use case approach. Therefore, the following tasks might be related to a coordination group: involvement of relevant technical committees, handling of overlapping use cases or missing ones, quality check, common tasks like maintenance of template, glossary, actors, and methodology in general.

On the other hand as already stated before the expertise of the involved TC's is required and they are expected to take over responsibility for a specific set of use cases within their scope of activities (suggestion of new use cases, detailing / maintaining / analysis of existing ones). So the relation between expertise and coordination has to be solved.

It also has to be stated that decisions about the implementation of a use case repository within the own organization or in cooperation with partner SDO's will be taken within the individual SDO's. Detailed processes have to be designed after these decisions. Nevertheless, the following can be seen as a proposal how this might look like. It is based on the current discussions in the SG-CG/SP and on international level (IEC).

### **6.9.3.3 Status of use cases in standardization**

If use cases are used today within standardization, they usually are internal working documents of a TC used to prepare standards or they are described in standards of this TC. Considering the approach of this report that use case approach should provide a collaborative platform between different TC's or standardization organizations, the status of use cases, collected in a repository, have to be discussed within the standardization organizations.

Currently the descriptions of use cases are seen as informative documents like a Technical Report (TR) or a Technical Specification (TS). In future it may be re-considered to define a new type of use cases standards.

### **6.9.3.4 Procedures for the maintenance of the IEC standards in database format**

By storing and maintaining use cases in a database or repository, it is expected that such a repository will fulfill the requirements for easy of accessibility to use cases also from a standardization cooperation perspective.

Some IEC standards are already available in a database format. These standards are accessible either free of charge, or via subscriptions which can be purchased through the IEC National Committees, National Committee-appointed Sales Outlets, or directly from the IEC Web Store. IEC also has specified a procedure as an IEC supplement to the ISO/IEC Directives which describes procedures for the maintenance of any international standard consisting of “collections of items” managed in a database (Annex J in the document ISO/IEC DIR IEC SUP Edition 6.0 2011-04).

As use cases will be collected also on an IEC level, it represents a good solution from a coordination perspective for use cases to be managed in an IEC supported database using the IEC database procedure. At least the existing database procedures as described below might serve as guidance for the implementation of the use case database / repository.

Figure 11 shows the IEC procedure:

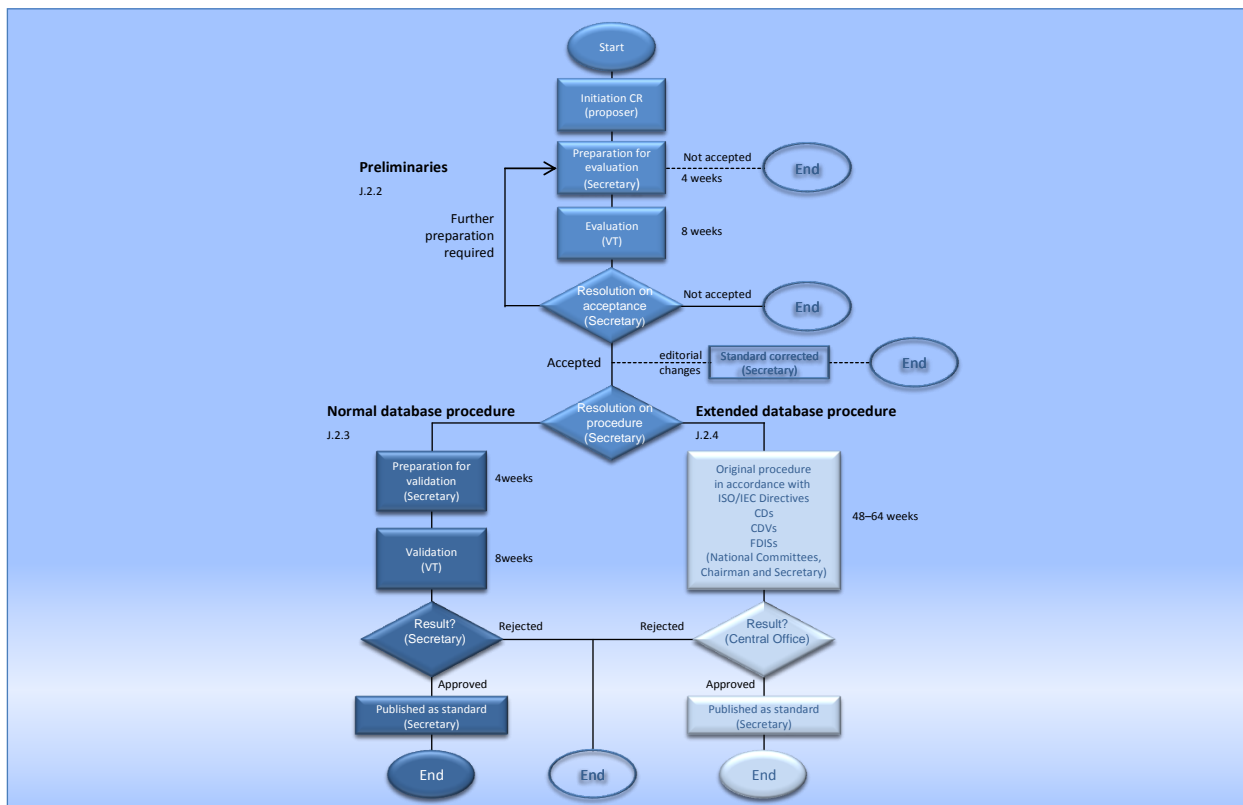

**Figure 11 – Overview of the procedures from [3], CR Change Request, VT Validation Team**

The main parts of the figure are explained in [3] as follows and can be adopted for the use case process in future:

Initiation of Change Request (CR) or new use case

Entering of a new use cases or a suggestion for a modification of an existing one as CR with the required information in a web-accessible database by an authorized person or body also referred to as “proposer”.

Preparation for evaluation

Preparation by the secretary of the technical committee or subcommittee (TC/SC) to ensure that all mandatory entries of the CR are appropriately filled in and that any associated graphics are of a quality sufficient for evaluation, although final quality is not needed.

If required, a Maintenance Team (MT) may be set up to assist the secretary in the preparation activities. When established, the MT has a one to one relation to a “database-based standard” (referred to in the procedure as “database standard”) and consists of members with expertise to assist the secretary in managing the maintenance of this database standard.

#### Evaluation of the CR

Action by the Validation Team (VT) to determine whether the CR is within the scope of the database and valid for further work or should be rejected.

When the quality of the information provided at the preparation stage is satisfactory, the status level of the CR is changed to for evaluation and the VT is informed (with copies to the proposer and possibly other relevant TCs) and asked by the secretary to make an evaluation and to comment.

The commenting is comparable to the commenting on a CD. The evaluation of the CR should be completed within 8 weeks.

For further details, see [3].

#### **6.9.3.5 Use case database for standardization purposes**

As use cases are developed and used for several other purposes than standardization, it is important to decide which use cases to store in an international database.

The requested collection of use cases in Europe, involving all Smart Grid stakeholders like technical and national committees, Smart Grid R&D projects and associations, was the basis for suggesting a first set of generic use cases as described in chapter 7.

The steps of developing commonly use cases and discussion of use case, validation and publishing might be strictly separated: e.g. discussion on the UCMR, voting on a discussed use case, publishing the use case in a standardization database (see below). The other possibility can be that the steps might be interlinked: e.g. the discussion on the collaborative platform is part of the validation process, validated use cases are not published separately – they just receive a different status within the same use cases environment (e.g. for comments /under discussion, for voting, accepted).

It is suggested that the generic use cases should be maintained in an international use case database according to the IEC procedure.

Based on the current activities and the IEC process as basis, the hosting of the international database within IEC has to be further evaluated as preferred solution. and first discussions on IEC level has been started. National or regional specific use cases, which preferably are based on international generic use cases, have to be considered.

#### **6.9.3.6 Utilization of existing IEC databases for use cases**

Two IEC standards in database format are of specific interest as their contents have use case relevance and thus need to be considered in the procedure:

##### Electropedia: The World's Online Electrotechnical Vocabulary – IEC 60050 series

- Electropedia (also known as the "IEV Online") is the world's most comprehensive online electrical and electronic terminology database containing more than 20 000 terms and definitions and is managed by TC1.

##### IEC 61360 - Component Data Dictionary (CDD )

- The IEC Component Data Dictionary (CDD) contains the IEC reference collection of classes and associated characteristic properties (data element types or DETs) for electric/electronic components and materials used in electrotechnical equipment and systems and is managed by SC 3D.

Both databases should maintain the standardized actor list and the CDD may also be the location to store generic use cases for standardization purposes.

The overall process is illustrated in Figure 12 and complements the validation process as described before:

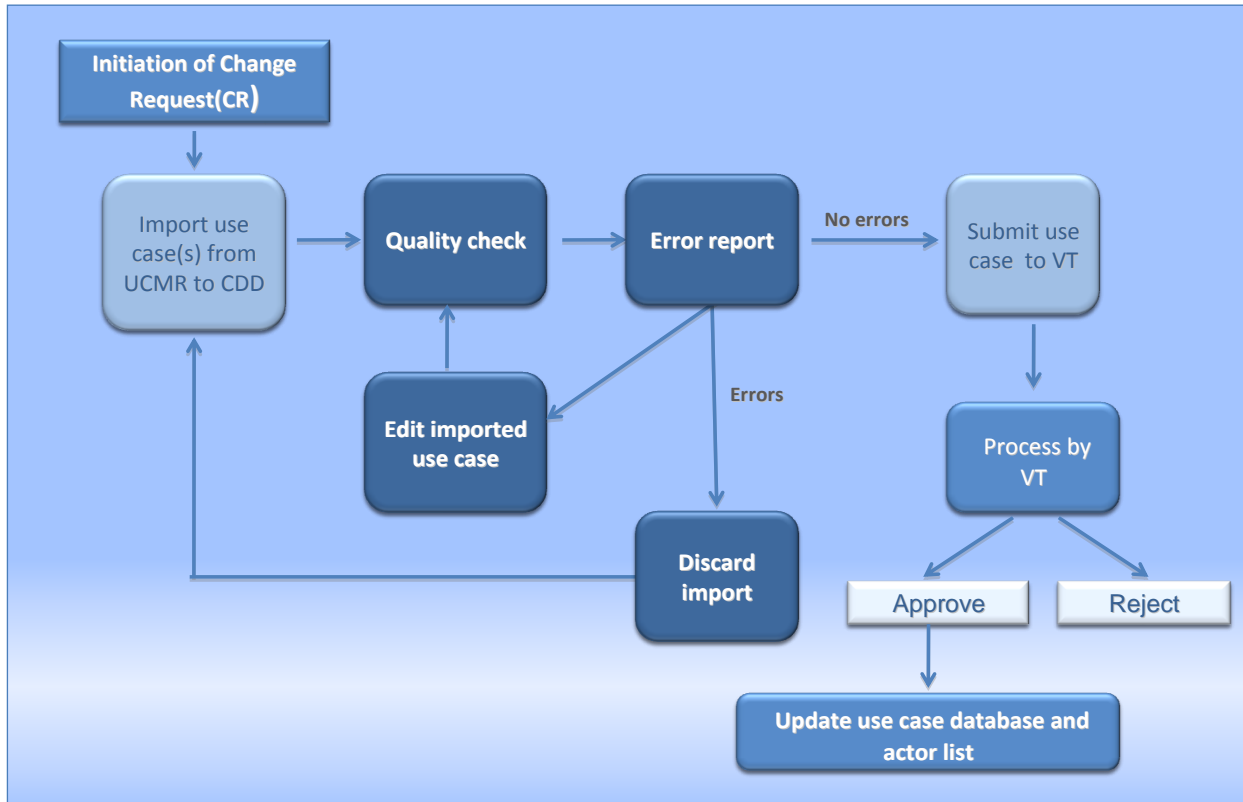

**Figure 12 – Overall process based on IEC/SC 3D workflow**

As shown in the figure, a quality check is included and hence quality rules or guidelines should be developed. Examples of high level rules might be:

- To check if the standardized use case template is applied and that the essential fields are completed
- To check if the standardized actor list is used or if additional actors need to be standardized

IEC SC 3D has drafted a quality guide for the IEC CDD, which could be adapted also to cover use cases.

SC 3D already have features and processes for version control, version history, language variants etc. that are of interest also for the use case management process.



## Recommendation

For the overall responsibility for the management of the process a new subcommittee might be set up as a joint working group (JWG) between IEC / SC 3D as responsible for the IEC CDD and IEC / TC 8 as this committee is working on the collection and methodology of use cases within IEC and its Technical Committees. To serve other TC's and cooperating standardization organizations this JWG should take over cross cutting tasks like the quality check of new use cases and change requests as well as the overall coordination as mentioned before as well as common tasks like the maintenance of template, glossary, actors, methodology in general. Experts from other TC's like TC 1, TC 3, TC 8, TC 13, or TC 57 as well as other stakeholders like CEN, CENELEC, and ETSI should support this joint WG.

## 7 Collection of use cases in the Smart Grid and analysis

The SG-CG/SP asked a broad variety of Smart Grid stakeholders to provide Smart Grid use cases using the relevant template (refer to UCMR) which was based on [1].

Use cases are referenced within this report and the UCMR as "ABCD-1234" whereas "ABCD" represents a short cut to the origin of the use case.

### Results of the collection

- Following a six week collation period over 450 use cases were provided from the various stakeholders.
- Main stakeholder groups included: Smart Grid research & development projects, Technical Committees (TC), National Committees (NC), individual companies, associations. A detailed list of all contributors are provided in Annex B and all use cases can be found in [26].
- Over 80% of the use cases received utilized the distributed templates. Other use cases were provided in a format very similar to the proposed template.
- Nearly all use cases were completed using the short template (the template was provided in three versions: detailed, general, and short). As the time frame for the collection was very short and in order to get a first overview of the use cases it was understandable and fully acceptable that only the short version template was used. By using the short version template this also aided the timely completion of the first analysis of the use cases.. Due to partly unclear titles of the use cases, the suggestion was made that future versions of the template should provide some recommendation for the definition of the use cases name (e.g.: Description of action).
- Using the short version template , 45 use cases were input directly into the online tool for new use cases (Use Case Management Repository, UCMR), partly in parallel to the WORD template. In addition all other use cases received were transferred into the UCMR where they can serve as the basis for a future knowledge base.
- The level of detail of the use cases provided was varied: some use cases were very detailed, some suggested some requirements to Smart Grids, partly just providing keywords while most use cases described the main ideas of high level use cases or business cases . Nevertheless, all use cases were helpful – at least to identify the key areas of interest.
- Due to the short time frame for the collection, it is assumed that most of the use cases had been taken from existing sources and therefore adapted to the suggested template. This might be the reason why the actors were often not chosen from the suggested actors' list. With the generic use cases and the support of the Use Cases Management Repository (UCMR) the actor list was consolidated and will be further updated.

NOTE Smart Metering - A number of smart metering use cases were provided, but were not analyzed in any further detail. These use cases are to be considered by the Smart Metering Coordination Group which is doing a similar use case exercise for Smart Metering.

Smart Grid Information Security - SG-CG/SGIS provided use cases which are specific to information security.

## Analysis

After an initial screening of the use cases received, all use cases have been fully analyzed.

As the mappings are individual interpretations during analysis, the statistics in Annex B showing a mapping of the collected use cases to domains, high level services or the suggested GUC can provide only some first insights. Nevertheless, this seems to be sufficient and valid enough in order to identify interesting and valuable information about areas of main stakeholder interest.

The proposed template would allow further statistical evaluations: e.g. the number of high level use cases, maturity levels, views like technical or commercial. But as a result of using the short version template, where this information had not been asked for, a deeper analysis according to the criteria of the template seems not to be beneficial within this report.

The initial analysis of the collected use cases resulted in the suggestion of clusters, conceptual descriptions and generic use cases (GUC)<sup>9</sup>. Some of them are detailed further by means of both the comments received and output from the stakeholder workshops.

Not all collected use cases have been used for this first selection of prioritized generic use cases. In further discussions and iterations they may also be considered as well. For example, several of these use cases might be needed for adding further detail to the proposed generic use cases.

## **8 Conceptual descriptions of the main use case clusters**

### **8.1 Introduction**

Based on the analysis of the use cases received during the collection period and the subsequent development of the generic use cases it was decided to introduce clusters of use cases by means of conceptual descriptions (refer to chapter 6.5.3). The conceptual descriptions should provide an overview and background to the main concepts as well as considering the first suggestions for functional architectures which are required to detail the generic use cases. The conceptual description or the conceptual model is seen as necessary to understand the generic use cases which refer to this description.

### **8.2 Conceptual description - demand and generation flexibility for technical and commercial operations**

#### **8.2.1 Introduction flexibility concept**

The concept of demand and generation flexibility is a cornerstone for the whole Smart Grid discussion, since this flexibility can significantly support an efficient integration of renewable energy sources into the energy system.

The flexibility concept encompasses:

- Demand Response (DR) and Demand Side Management (DSM) – see below – as a means to achieve flexibility in demand, generation and storage.
- The customer actively providing flexibility to the market

The flexibility of customers could be used for grid operation or within existing or new energy markets.

---

<sup>9</sup> refer to chapter 8 and 9

Therefore this chapter intends to provide an overview of network user/customers flexibilities and related energy markets, mostly referring to Demand Side Management (DSM) or Demand Response (DR) and to suggest a first generalized approach for the provision of flexibility which will lead to the suggestion of first generic flexibility use cases.

### 8.2.1.1 Definitions

In the following section some definitions around providing and using flexibility are formulated. For more details, please refer to the literature listed in the chapters 2 and 12. The concept described in these definitions are elements of a flexibility model where both the grid/market and the customer can take the initiative to use or offer flexible demand/generation/storage.

When referring to Demand Response and Demand Side Management, within this report the following definition of EURELECTRIC in its paper “*EURELECTRIC Views on Demand-Side Participation*” [28] is used

Quote

- Demand Side Management (DSM) or Load Management has been used in the (mainly still vertically integrated as opposed to unbundled) power industry over the last thirty years with the aim “to reduce energy consumption and improve overall electricity usage efficiency through the implementation of policies and methods that control electricity demand. Demand Side Management (DSM) is usually a task for power companies / utilities to reduce or remove peak load, hence defer the installations of new capacities and distribution facilities. The commonly used methods by utilities for demand side management are: combination of high efficiency generation units, peak-load shaving, load shifting, and operating practices facilitating efficient usage of electricity, etc.” Demand Side Management (DSM) is therefore characterized by a ‘top-down’ approach: the utility decides to implement measures on the demand side to increase its efficiency.
- Demand Response (DR), on the contrary, implies a ‘bottom-up’ approach: the customer becomes active in managing his/her consumption – in order to achieve efficiency gains and by this means monetary/economic benefits. Demand Response (DR) can be defined as “the changes in electric usage by end-use customers from their normal consumption patterns in response to changes in the price of electricity over time. Further, DR can be also defined as the incentive payments designed to induce lower electricity use at times of high wholesale market prices or when system reliability is jeopardized. DR includes all intentional modifications to consumption patterns of electricity of end use customers that are intended to alter the timing, level of instantaneous demand, or the total electricity consumption”. DR aims to reduce electricity consumption in times of high energy cost or network constraints by allowing customers to respond to price or quantity signals.

End quote

In “MIRABEL - Micro-Request-Based Aggregation, Forecasting and Scheduling of Energy Demand, Supply and Distribution”, the following definition of the Flexibility Offering concept [8] can be found.

Quote

- The flexibility [offering] concept assumes that parties connected to the grid produce offerings of flexibility in load and (distributed) generation. Thereby, so-called flex-offers are issued indicating these power profile flexibilities, e.g. shifting in time or changing the energy amount. In the flex-offer approach, consumers and producers directly specify their demand and supply power profile flexibility in a fine-grained manner (household and SME<sup>10</sup> level). Flex-offers are dynamically scheduled in near real-time, e.g. in case when the energy production from renewable energy sources, such as wind turbines, deviates from the forecasted production of the energy system.

---

<sup>10</sup> SME Small and Medium-sized Enterprise

End quote

### 8.2.1.2 Providing and using flexibility

The area of demand and generation flexibility consists of two major areas (see Figure 13), each of which will be described in a different chapter.

- the network user / customer, providing flexibility, see chapter 8.2.2
- the grid and / or market(s), using flexibility, see chapter 8.2.3. This might be existing markets possibly with appropriate adaptations and/or new entrants, or new “smart markets”<sup>11</sup>

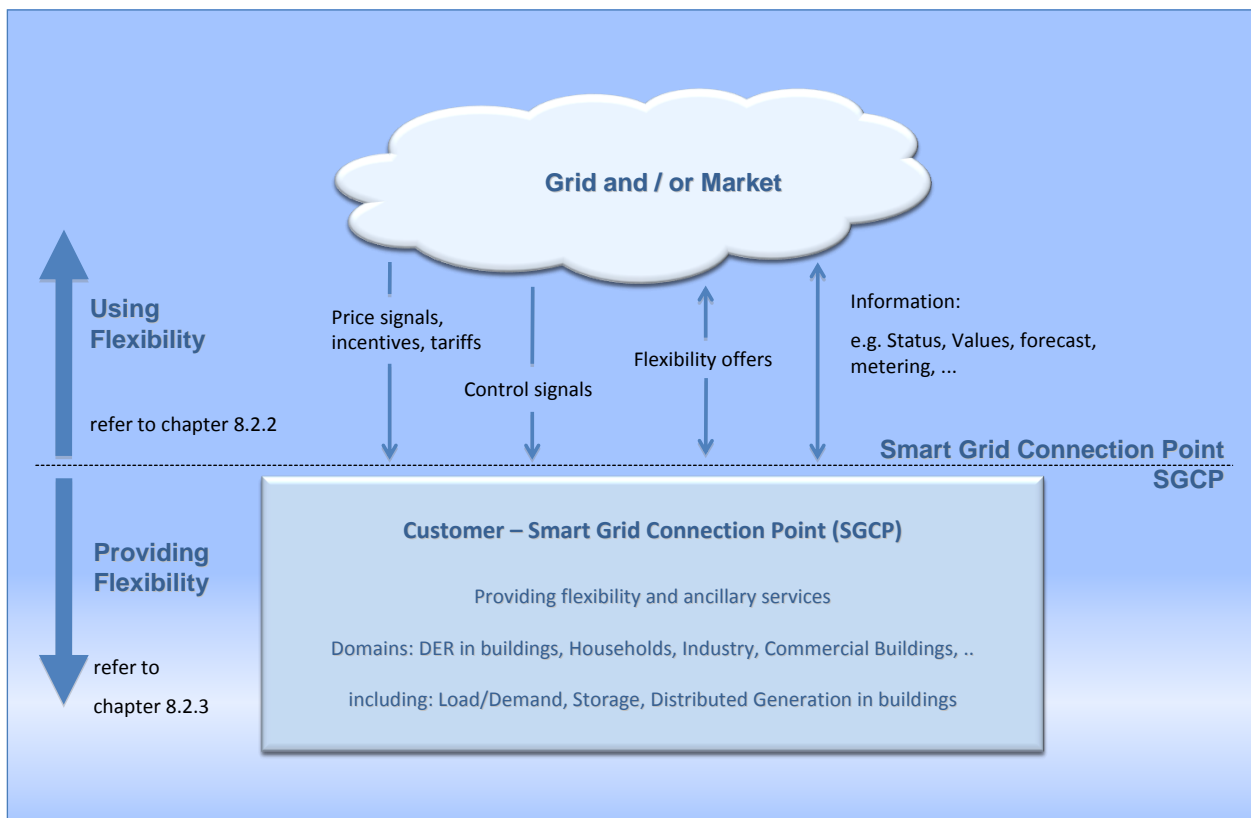

Figure 13 – Smart Grid Connection Point – conceptual model

### 8.2.1.3 Smart Grid Connection Point (SGCP)

In this conceptual model, the Smart Grid Connection Point (SGCP) defines the physical and logical borderline / interface from the customer to the network/market or from the network/market to the customer considering small scale generation, storage or demand. The SGCP can be implemented by one or more separate interfaces (e.g. Smart Metering Gateway to an external actor).

<sup>11</sup>For instance BNetzA (German regulator) distinguishes between Smart Grid and Smart Markets, whereas Smart Markets comprises all new energy service which stem from marketing flexibilities etc. [27]

The SGCP can be used as an abstraction that will help to reduce the complexity in the description of the interactions between different "domains" such as grid/market and "resources" in a general meaning (DER or customer premise) or as shown in Figure 13 between "providing flexibility" and "using flexibility".

The different physical or informational "flows" that pass through the SGCP depend on the services defined between market/grid and the customer. The definition of these are dependent on different functionalities, which should be standardized taking into account as far as possible that there might be different regulations as well as market models as defined by the respective authorities for these functionalities. In the following the flexibility concept concentrates on the generic functionalities for this interface based on use cases that were received in the use case selection period and consequent discussions in the SG-CG.

For a flexibility operator or a balancing responsible party (BRP) the demand or generation flexibility of the SGCP just represents positive or negative control power. In order to define these flexibilities, the supported use cases at a specific SGCP can be used within an auto registration process (see chapter 8.2.4.1).

### 8.2.1.4 Flexibility functional architecture

Most use cases are describing the DR/DSM together with automation functions on the customer side, here called the Customer Energy Manager or CEM.

It seemed that there was quite a harmonized view on a functional architecture in the evaluated use cases. The picture below represents a generic functional architecture for the flexibility use cases.

Here, the CEM provides the flexibility of connected smart devices, through the energy management gateway, while the smart metering and the simple external consumer display provide a number of functionalities which are described in more detail in work of the Smart Meters Coordination Group. The energy management gateway communicates with the metering channel and the smart metering through the Smart Metering Gateway. The gateways in this architecture split different networks (Wide Area Network, Neighborhood Area Network and Local Area Network) and may be, as further described below, integrated with other functional entities.

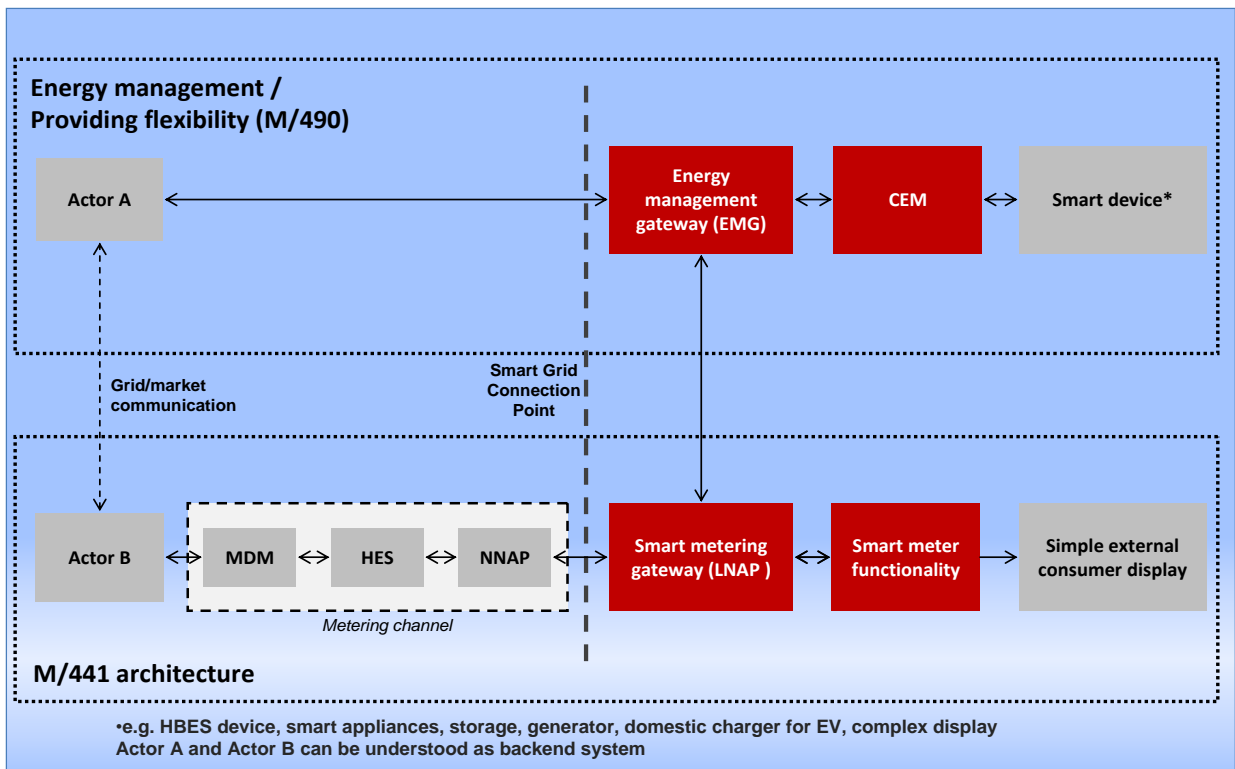

Figure 14 – Flexibility functional architecture (for abbreviations see footnote 12)

Note that the actors in the above architecture are functional entities, which means that some of them may be part of the same physical device (e.g. CEM functionality may be part of a smart device, the smart meter might also encompass the smart metering gateway and CEM, etc...).

Note that the communication path between the smart metering gateway and energy management gateway is optional (as are all communication path is in this architecture). In the aforementioned case, the information exchange between the metering channel and energy management channel will take place between Actor A and Actor B.

The external actors A and B, identified in this functional architecture represent (systems of) market roles that communicate through the Smart Grid Connection Point. Examples of these roles are a meter data collector, meter operator, aggregator, supplier, flexibility operator, etc. The actual role of actor A or B depends on the local market organization in a member state and competition. In the scope of this report, actor A is defined as the external actor communicating with the energy management gateway while actor B is defined as the external actor communicating with the smart metering gateway.

Functionalities of HES, NNAP, LNAP<sup>12</sup>, smart metering and the simple external consumer display are described in more detail in the functional metering reference architecture according to SM-CG (TR50572 [10]). The communication in the metering channel (going via MDM, HES and NNAP) is not described in detail in the use cases of the flexibility cluster since, in these use cases, their function is to pass through the information sent between smart metering gateway and actor B. Although the NNAP and LNAP can include intelligence to locally and independently implement Smart Grid services and applications, their service in the current flexibility use cases is to pass through the information.

This functional architecture can be mapped in the following way on the Smart Grid Architecture Model (SGAM) as defined by SG-CG/RA.

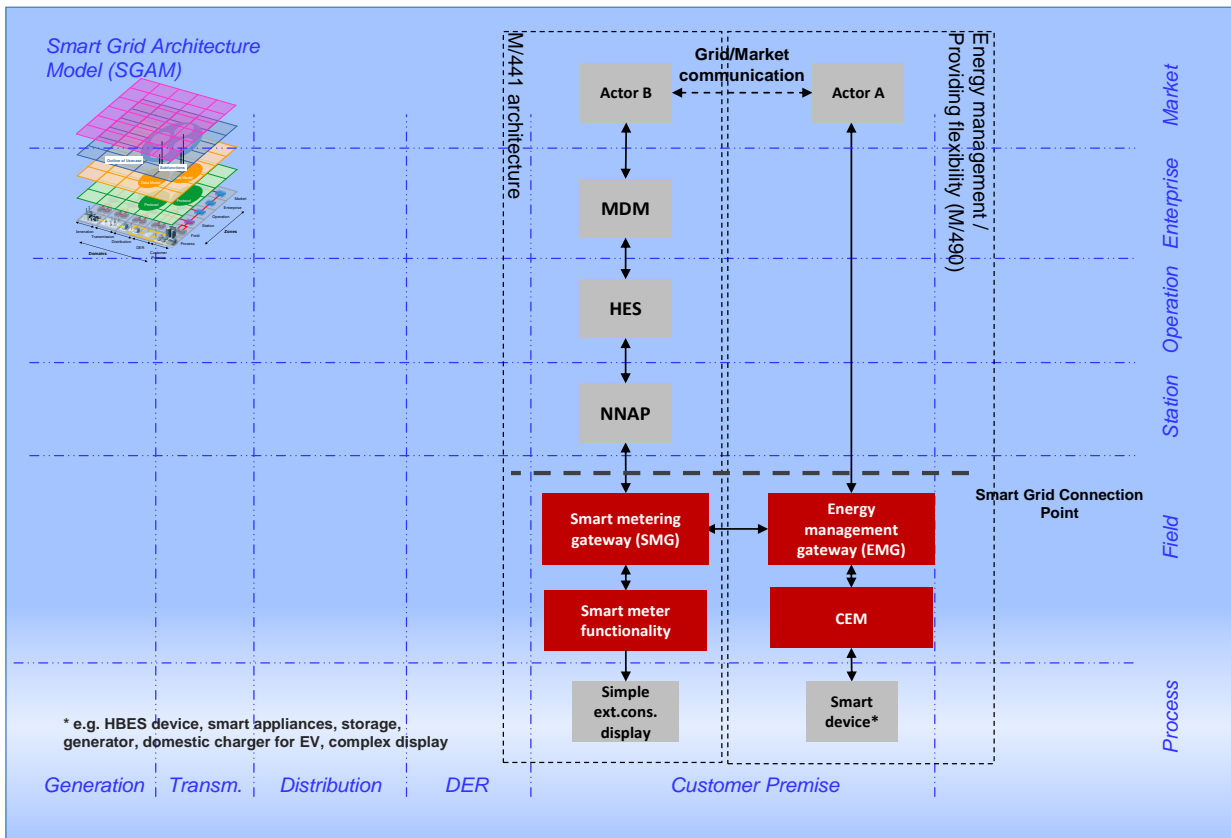

<sup>12</sup> HES Head End System, MDM Meter Data Management, NNAP Neighbourhood Network Access Point, LNAP Local Network Access Point, HBES Home and Building Electronic System

**Figure 15 – Mapping of flexibility functional architecture on SGAM**

## **8.2.2 Network user / customer providing flexibility - Introduction**

The following initial findings and interpretations of the SG-CG/SP are based on the collected use cases. This resulted in a number of suggestions and recommendations for concepts with respect to general functionalities and information architecture.

### **8.2.2.1 Customer Energy Manager (CEM)**

Under the SGCP, two logical systems are present: a smart metering and a CEM. Together, they define the logical and physical borderline and interface from the customer to the grid/market or from the grid/market to the customer.

Although tariff changes without automatic response like time-of-use tariffs (TOU) are possible and considered as a simple DR application, an automatic reaction on tariff changes, like e.g. a combined real-time price / volume tariff or other signals from outside shall make use of customer's flexibility more efficient. This automatic reaction will be managed by the Customer Energy Manager (CEM).

The CEM is a logical function optimizing energy consumption and or production based on signals received from the grid, consumer's settings and contracts, and devices minimum performance standards. The CEM collects messages sent to and received from connected devices; in particular in the in-home/building sector. It can handle general or dedicated load and generation management commands and then forwards these to the connected devices. It provides vice versa information towards the "grid / market". Note that multiple loads/generation resources can be combined in the CEM to be mutually controlled.

The CEM together with a Smart Metering System (SM) for metrological data and as a gateway for tariff and billing information are the logical gateways between the two areas<sup>13</sup> shown below. A logical difference between CEM and smart metering is created in order to provide logical functionalities and use cases for standardization. The deployment of these function blocks will depend on the technologies supplied and may or may not lead to physically separated devices<sup>14</sup>.

The figure below depicts a simplified structure of the CEM at the customer side of the SGCP.

---

<sup>13</sup> grid / market at the one hand and network user / customer at the other

<sup>14</sup> for a more detailed description please refer to the generic use cases of the flexibility cluster in the UMCR

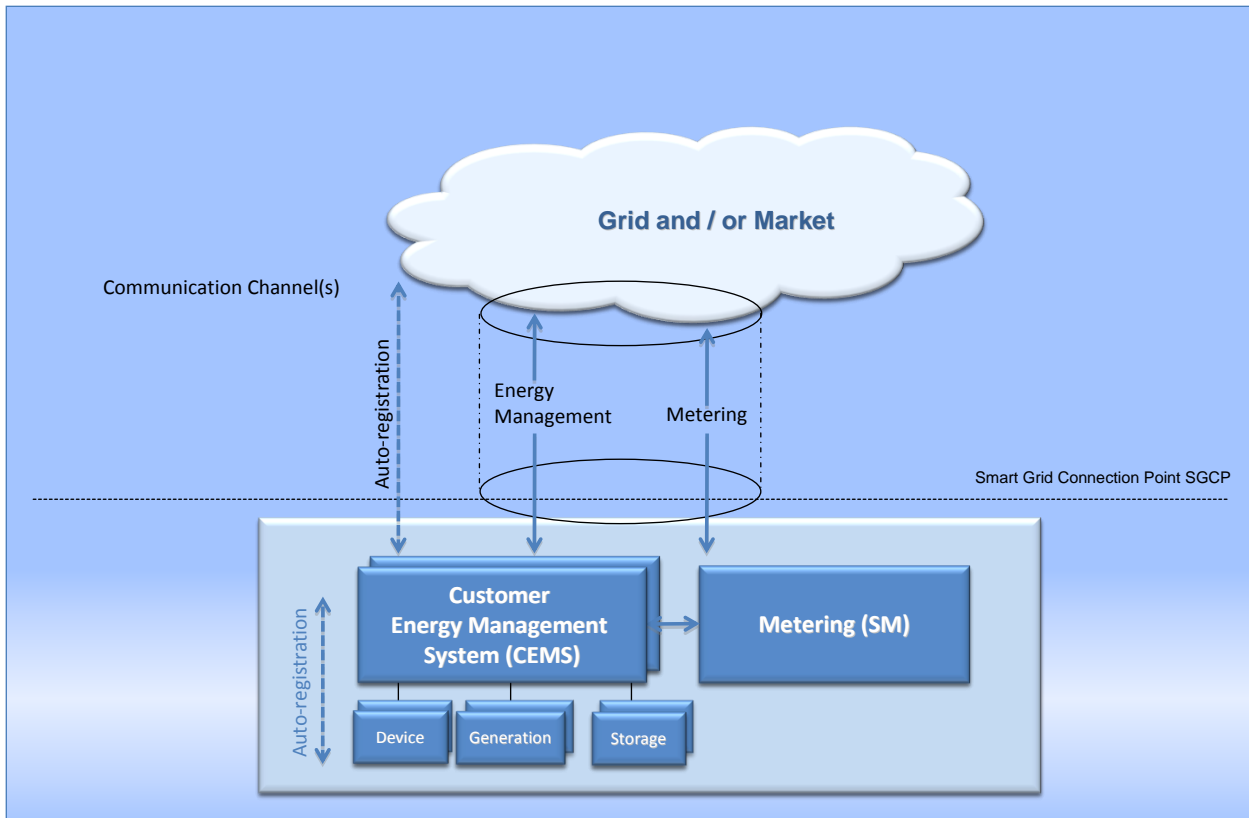

**Figure 16 – Simplified structure of a CEM - Customer Energy Manager** (based on Figure 13)

Although most suggested concepts are based on the idea of one CEM per home / building which coordinates different devices internally, this is not a pre-requisite. The CEM could be a central smart unit, or could be made up of several smart units built in a device: e.g. one for a smart appliance for the connection to a flexibility operator and another CEM for the direct connection of a PV system to the grid.

On the other hand the CEM might be part of a general automated system for home, industry or building where sensors or actors are integrated/summarized and controlled for different purposes. In this case the CEM represents functionalities within the overall automated system.

The CEM may also be combined with smart metering functionalities in the smart metering system. Tariff changes had always been a function of the metering<sup>15</sup>, and some existing smart meters already have CEM functions in order to make these changes usable by the appliances, e.g. either with analogue or digital outputs in order to control appliances according to these tariff changes or to provide them with the tariff information.

Alternatively the CEM might be part of a single device like a Combined Heat & Power (CHP) unit or a heat pump or a smart appliance which can be connected directly. In this case several CEM's may well be in one house. Nevertheless, the collected use cases are describing the functionality by means of a single CEM in the house/building in order to provide an internal optimization between different devices<sup>16</sup>.

Below are some examples of CEM configurations.

<sup>15</sup> IEC/TC 13 Electrical energy measurement, tariff- and load control, scope: [http://www.iec.ch/dyn/www/f?p=103:7:0:::FSP\\_ORG\\_ID:1258](http://www.iec.ch/dyn/www/f?p=103:7:0:::FSP_ORG_ID:1258)

<sup>16</sup> As example: the reduction of the feed-in of a PV can be linked internally to a storage system like an EV. The single CEM of a PV only connected to the SGCP would have to reduce the generation whereas the internal link makes use of the full generation.



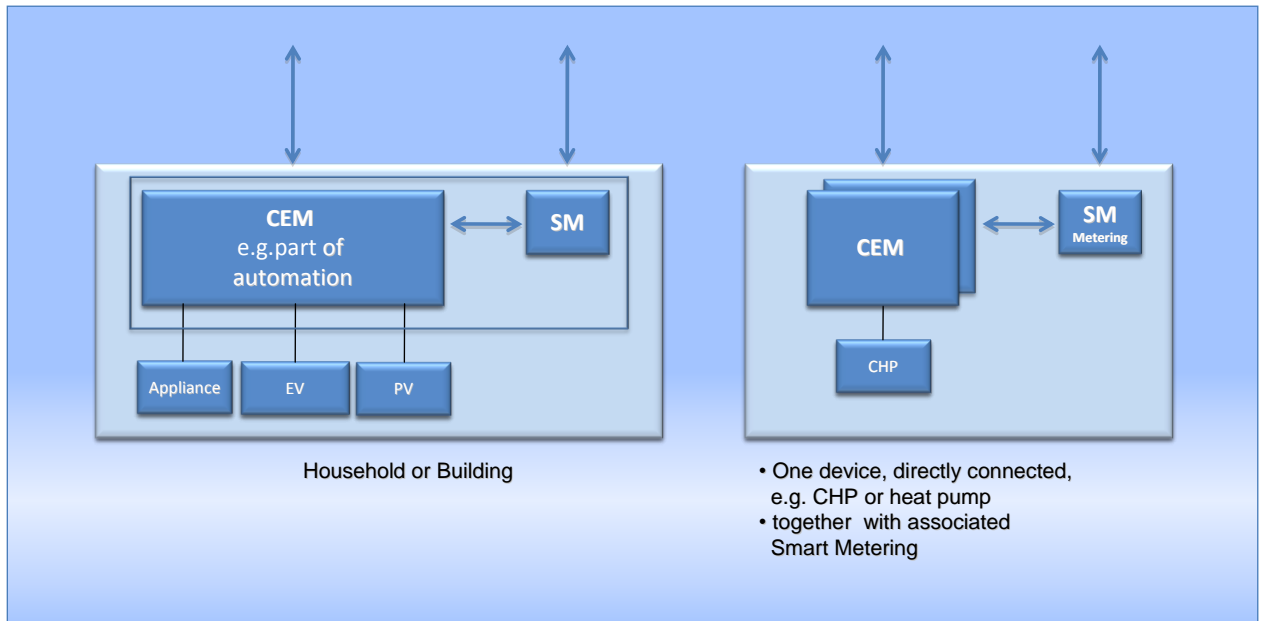

**Figure 17 – Examples for CEM configurations<sup>17</sup>**

A lot of the use cases are dealing with the smart home, smart building or the charging of Electric Vehicles (EV) behind the Smart Grid Connection Point. The concept of the CEM and SM seems to be broadly accepted (for SM, please, refer for further details to the Smart Metering Coordination Group SM-CG [8]).

Internal use cases from the CEM towards devices are not detailed here, as this is not in the scope of the mandate M/490. They are listed in an overview and in the repository. Those use cases shall be detailed in the respective technical committees for home/building automation<sup>18</sup> or product committees dealing with the automation functions.

The use of network user flexibilities of industry or commercial buildings / infrastructure seems to be in the minority of the received use cases to date, although they represent a bigger potential for e.g. load shifting measures due to higher power ratings. These measures are already in place today for customers with special contracts and high consumption. Following public discussions it seems that these sectors will soon be a priority (e.g. E-Energy [31]). The use of flexibilities are equally valid for these customers, although maybe bigger players like an industry park or facility management for buildings may also act as a flexibility operator directly negotiating in a local, regional or even national / international market (which is for some big players is already the case today).

## 8.2.3 The interaction of markets and use cases in relation to the delivery of flexibility services

### 8.2.3.1 Introduction

In this chapter consideration will be given to a number of use cases provided by a range of stakeholders, which focus on both market and grid operation alongside DR/DSM in relation to the delivery and receipt of 'flexibility'. It is important to note that the flexibility provided at the Smart Grid Connection Point can serve very different purposes broadly split into technical and commercial purposes, which will be considered in more detail within the high level use cases explored in this chapter. However, it should be noted that new market

<sup>17</sup> drawings are showing optional solutions, further details are explained in the generic use cases of the CEM

<sup>18</sup> e.g. CENELEC / TC 205, CEN / TC 247 on European level or IEC / TC 57 WG 21, TC 8 WG 6 DCT 6, PC 118 on international level. Similar functions for the flexibility are related to Smart Charging which is described as a separate cluster in the following chapter. Also here several TC's and WG's might be involved, refer to Table 3 – Mapping of generic use cases to involved Technical Committees

models, which are using the flexibility provided <sup>19</sup>, are still emerging through the work being undertaken by the Smart Grid Task Force Expert Group 3 (EG3) and therefore further harmonization and development will be required. Nevertheless, this chapter will focus on the role of use cases within the broader standardization process in order to support the future market whilst not artificially limiting the range of possible solutions. However, in general within this chapter the report will focus on two major blocks namely the **use of flexibility** and the **provision of flexibility** as described in the previous chapter.

### 8.2.3.2 Current and future market roles, responsibilities and relationships

The increased participation of **flexible resources** for example renewable energy sources – including smaller, distributed resources – will present new challenges to the operations of existing electricity transmission and distribution systems on the technical side, and to existing markets on the commercial side. Generally, the two physical variables of concern when considering these flexible resources in the context of the stable operation the transmission and distribution system are Power and Voltage:

1. **For voltage**, statutory limits define the maximum and minimum voltage that a DSO can operate the grid at.
2. **For power** it is the physical limits of the network (e.g. lines, cables, transformers, and switchgear) that define the secure operating region.

In light of a variety of policy goals and market drivers, such as energy market liberalization, greater customer involvement in energy markets through distributed generation, new energy efficiency services, these two variables are being put under increased pressure.

#### Where and in what way will the use of flexible resources impact the current power system?

The use of flexible resources in the power system can occur over different time horizons (i.e. can be considered over longer time periods of a year or more) and touches on a number of areas such as:

- **System balancing** – ensuring frequency stability, preventing deviation between measured and scheduled inter-control-area power exchange, etc.
- **Local network constraint management** – ensuring grid capacity isn't exceeded (on different voltage levels) and that voltages remain within the statutory limits
- **Voltage / VAr optimization** – see WGSP-0200
- **Network restoration and black start** – using flexibility in energy resources for 'orderly' restoration
- **Power flow stabilization** – reducing the variation in power flow across (network) assets to increase asset lifetime
- **Market balancing** – reducing the difference between scheduled and measured inflow/off-take of market participants
- **Energy market participation** – participation of any (aggregated) flexible resources in energy markets (on time scales varying from e.g. minute-ahead to day-ahead)

The market participation of (aggregated) flexible resources is an emerging area and is subject to much on-going research. The use of flexibility resources, in the ways identified above, will present a number of impacts and drive new interactions between existing (and new) actors which could be co-ordinated in a number of ways within a given market. Therefore, conceptualizing the impact to grid and market operations within a number of key states from accommodating increasing volumes of flexible resources is important in supporting understanding of the instances in which new use cases and standards are likely to emerge.

#### Identifying the contribution of 'flexible resources' within different grid and market operating states

---

<sup>19</sup> existing energy markets are described in [20], [19], for standard contributions to existing markets, please refer to IEC / TC 57 CIM

A helpful framework to aid consideration of the identification of key interactions between the roles of existing actors and future actors and the impact of flexible resources within in different states of grid and market operation is the Traffic Light Concept (TLC) illustrated in Figure 18.

Using the TLC, potential future grid and market interactions could be considered as follows:

The **green shaded** region defines the region where the 'smart market' competitively operates freely; the DSO may or may not interact with the market at this point. This should be seen as the 'normal operating state.'

The **yellow state** indicates the state where the DSO actively engages with the market in order to keep the system from becoming unstable, it is therefore a temporary state preventing the grid from entering the red state. This could be by executing pre-agreed contracts or by stepping in to procure in real time at market prices. This does not mean that the customer has to accept any situation where a third party (DSO) decides when they can use what is in their home or business premise. Instead intelligent solutions and economic incentives should be provided to allow the customer to decide and accept some limits.

In the **red state** the DSO needs to take control of market interactions in a certain area where the constraint has occurred. However, actions in this state must be specific and well defined and be temporary in nature. In this situation the DSO can override contracts existing in the market, execute dedicated emergency actions through flexibility operators, or execute direct controls over generation or demand in order to re-stabilise the system as far as a contract or regulation / legislation allows to do so.

In simple terms the TLC assumes that the highest premise is system availability, with the grid operators as the responsible actors. The traffic lights themselves inform the market participants of grid constraints, whereby price and control signals steer market actions. Here the TLC is also a use case itself and not only a general framework. But as framework for thinking it is helpfully illuminates a key boundary area which is the 'amber' region between areas whereby DSOs offer market participants the opportunity to deliver system support services. Within the 'amber' region assured available flexibilities are essential for the interaction between market and grid. DSO planning should allow the DSO to use flexibility via market solutions or to verify traded flexibilities, where this is more efficient and effective than investing new assets. However, the red shaded state is not a long term substitute for necessary grid investment. Finally from a customer perspective it is important to recognize and be sensitive to the fact that customers will not accept, unless incentivized or required by law under grid codes, a wholesale imposition of the situation where a third party (DSO) decides when they can use what is in their home or business.

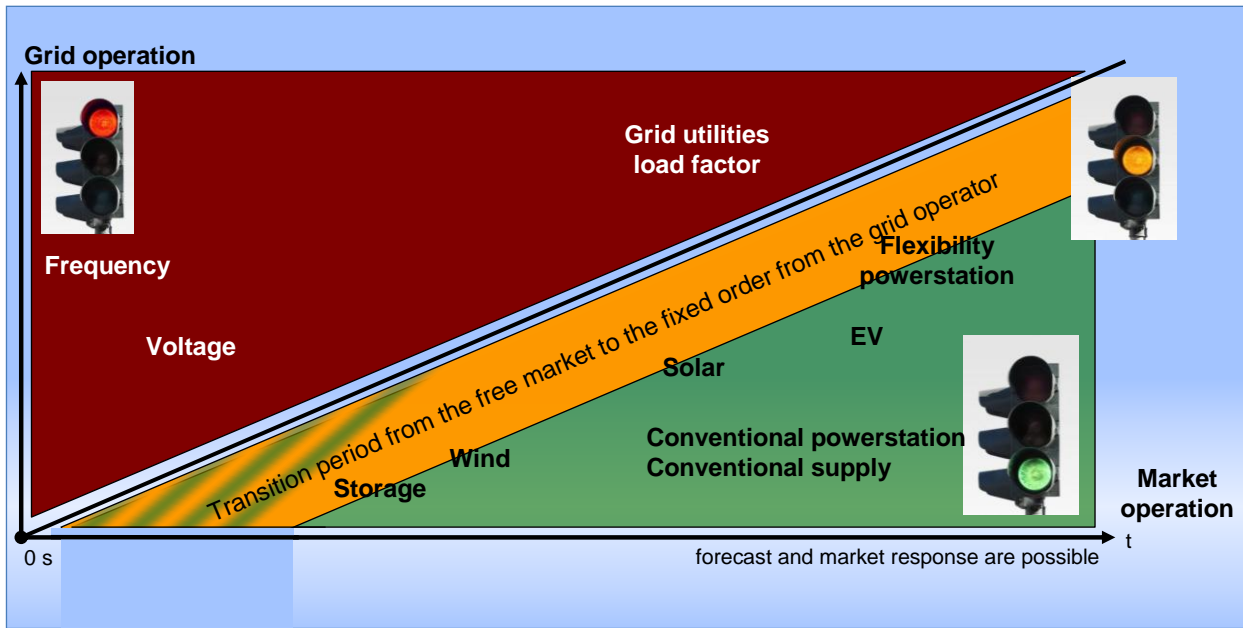

Figure 18 – Traffic Light Concept (Source: BDEW German Association of Energy and Water Industries )

### 8.2.3.3 Assessing the impact of the use of ‘flexible resources’ on local network constraint management

The use of flexible resources, for example in the ways identified above, may interfere with the use of other resources to integrate intermittent generation in a commercial trade portfolio and due to local network constraints may cause congestion. At this level interaction between these actors may potentially be coordinated in various ways, including but not limited to:

- **Green Situation** - Grid or system operator originated incentives – application of general pricing, penalties or rebates/compensation based location<sup>20</sup>, time, imbalance, load factor, etc.
- **Red Situation** - Grid or system operator overrides – override of control (directly or indirectly) of supply or demand in certain cases (‘emergencies’), governed by e.g. regulation or contracts.
- **Green/Yellow Situation** - Grid or system operator acquiring flexibility services – grid or system operators explicitly acquiring flexibility services to implement some of the use cases mentioned above; possibly governed by service level agreements on e.g. guaranty of availability, delivery time.
- **Green/Yellow Situation** - Schedule validation – the use flexible resources in relation to system / grid related constraints can be coordinated by a process of schedule validation by system / grid operators<sup>21</sup>.

The original use cases that served as a basis for this concept description are: ENNET-0001 through ENNET-0018, and the use cases described in the ADDRESS project. Identification of further relevant use cases and further analysis of relevant use cases is required to work out generic use cases.

<sup>20</sup> E.g. location marginal pricing

<sup>21</sup> This is an existing process used on the ‘higher system levels’, but which may be ‘extrapolated’ to e.g. the distribution level.

### 8.2.3.4 Moving towards a 'smarter energy' future

The drivers behind the shift towards a smarter energy future are well known, however, in light of the expected shift to electric mobility, the electrification of domestic heating and the integration of intermittent renewables and DERs, the important role of flexibility operators in supporting system availability becomes even more pronounced.

Within the TLC the role of the flexibility operator has been suggested as acting towards both new and existing markets. These complex market interactions are not in the focus of this report, but again the TLC can provide a useful framework for exploring use cases:

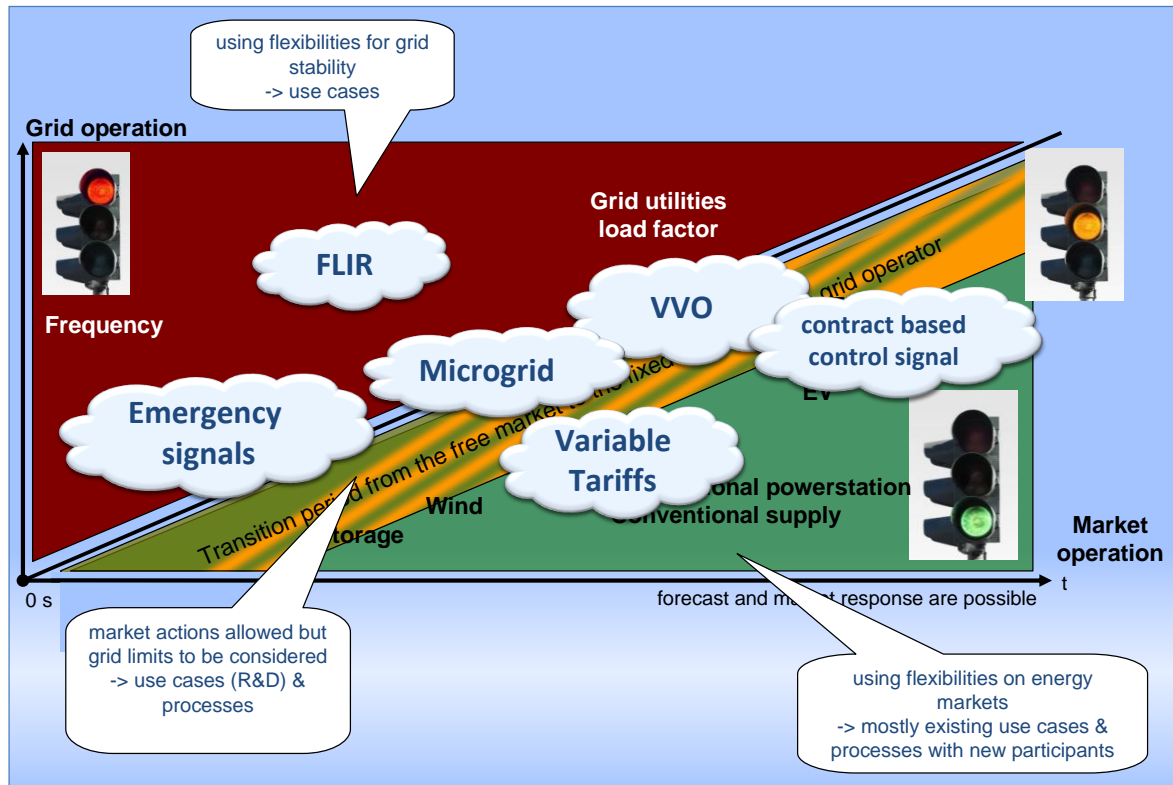

Figure 19 – Traffic light concept and use cases

Current, complex markets are not described in detail within this sub-chapter as they are mature and use cases in this area are not part of the Smart Grid Mandate M/490 (refer to [20]). Nevertheless, it is worth emphasizing that a number of possibilities with respect to future market designs and energy related products influencing flexibility use cases and related ICT interfaces exist.

Today markets are realized mainly on a transmission level (control areas with balancing authorities, wholesale markets such as EPEX and EEX<sup>22</sup>). Participation is only possible for market participants who provide a large volume of energy (several MW, but decreasing currently) and which have passed a prequalification. These wholesale markets will continue as set out in the third package and the relevant grid codes. In this future world the Smart Grid Connection Point will represent the critical interface/boundary between the **use** of flexibility by the grid and/or market and the **provision** of flexibility. The Smart Grid Connection Point (SGCP) is discussed in more detail in chapter 8.2.1.3 and Figure 13.

<sup>22</sup> EPEX European Power Exchange <http://www.epexspot.com/en/>; EEX European Energy Exchange AG <http://www.eex.com/en/>

### 8.2.3.5 Grid and market area – using the flexibilities

In this sub-chapter, a number of the use cases offered by stakeholders market and/or grid’s use of flexibility will be explored. It is worth noting that **the flexibility provided at the Smart Grid Connection Point can serve very different purposes in this area. An overview is provided in this chapter.** However, in comparison to the aforementioned customer area, it is evident that in relation to new market models which harness the ‘provided flexibility’ that further development and harmonization is required. Nevertheless, the following use cases have been provided as a base to start from and encase consideration of the standardization effort required in order to support emerging future market models. **Although it is important to stress the intension here is not to artificially limit the range of such models and the possible solutions within them.**

In general it may be differentiated between two major blocks on the “grid and market” side:

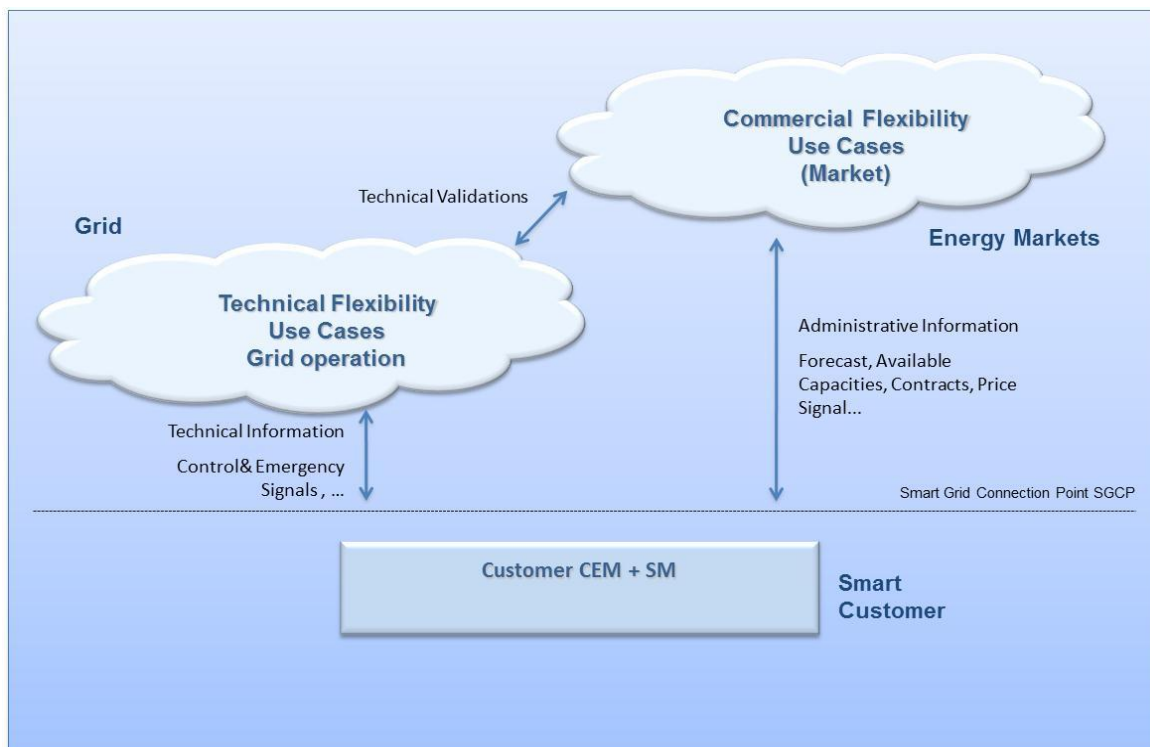

**Figure 20 – Commercial and technical flexibility use cases in the grid and market area<sup>23</sup>**

#### Exploring technical and commercial flexibility use cases

In this sub-section the proposed use cases referring to ‘technical’ and ‘commercial’ flexibility are briefly described.

#### Operation dealing with **technical flexibility** use cases (Cluster)

*The primary task of these use cases is to stabilize the grid in the given limits for power quality.* The following key actions are suggested under these use cases, reflecting different sections within the previously discussed ‘Traffic Light Concept’.

Use Cases:

---

<sup>23</sup> Generic use cases (e.g. DR/DSM) are providing flexibility and offer the basic functionality for both, technical and commercial flexibility. There will be “higher level” use cases dedicated to either technical or commercial.

1. The Distribution System Operator (DSO) sends a control request for stability reasons (e.g. emergency signals, load shedding, need for reactive power, requesting more or less generation).
2. DSO receives information from e.g. the Smart Meter with<sup>24</sup> information regarding power quality, outage, ...
3. **Yellow Situation** – DSO reacts: e.g. providing a correction (price, control) for market price signals in case of local grid overload (Congestion management) or in a **Red Situation** sending direct command signal according to legislation or contractual situation.
4. The DSO is the actor / market role for the technical use cases within the operation block.
5. Those technical demand response control functions might be used by other high level use cases like Microgrids (MG) or Volt Var Optimization (VVO), please refer to the respective generic use cases.

#### Operation dealing with **commercial flexibility** use cases

It is worth emphasizing that the general premise employed here is that the application of commercial flexibility use cases can be differentiated. The general instances in which commercial flexibility use cases are likely to be relevant include:

#### **Energy and balancing power**

- Selling, buying, trading energy (whole sale markets) based on prices in a liberalized market environment
- balancing (after market closure)

#### **Existing or new markets**<sup>19</sup>

- Existing energy markets: several use cases suggest the use of additional flexibility which has to be gathered in order to participate in existing markets (primary, secondary, tertiary markets, intra-day, day-ahead ...)
- New markets are suggested for real time corrections, e.g. within a balancing area

#### Consideration of geographical information and technical limits, such as limited line capacity

Following an assessment of the use cases received to date, a number of generic actor groups have become clear. In order to ensure that modeling remains at a 'general level' and future proof, it is suggested that the roles of general generic actors such as the 'Flexibility Operator' are mapped to possible roles alongside the actors listed below.

Typical generic actors and market roles mentioned in the use cases provided include:

- *Aggregator,*
- *Market place*
- *Energy supplier*
- *Agent*
- *Balancing Responsible Party (BRP)*
- *Balancing Group Coordinator (BGC),*
- *Distribution System Operator (DSO),*
- *Transmission System Operator (TSO)*

However, as Figure 21 below illustrates in practice it is likely that these use cases will be related to different time scales, namely Wholesale markets -> balancing power markets -> Automatic control (technical use cases, operation).

---

<sup>24</sup> Discussions, if the information must be anonymous due to privacy considerations or if e.g. local geographical information is required

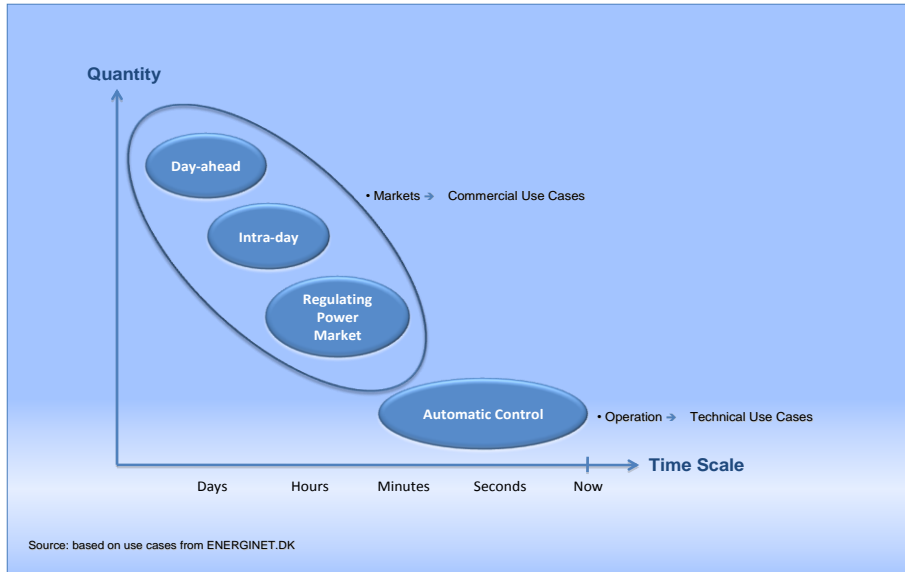

**Figure 21 - Use of flexibility options on different time scales**

### 8.2.3.6 Use cases and market interactions – exploring the role of the flexibility operator

In this section the role of the flexibility operator will be explored, with relevant potential use cases noted which may interact with a range of possible market models. It should be emphasized that potential market models and regulation continue to be developed in this area. In particular the output from the European Commission’s Smart Grid Task Force Expert Group 3 (EG3) will have an important impact on the use cases relating to the role of the flexibility operator. Therefore, use cases should be revisited, iterated and updated as the output from this group with respect a market model for Smart Grids is finalized.

**Nevertheless, the role of the flexibility operator is a general role that pools the small flexibilities of customers / network users (e.g. from CEMs) in order to make use of them in the grid or on energy markets.** The basic concept of the flexibility operator seems to be widely accepted, although the name of the flexibility operator and its detailed tasks are varying. The concept is often referred to as an aggregator, but in this case the name should underline the general role concept of “Using flexibility”. According to the description of the role concept, the generic actor “flexibility operator” might be carried out by existing market roles like energy suppliers with variable prices, aggregators, Virtual Power Plant (VPP), energy servicing company, agent, etc. (refer to [19]).

It is worth emphasizing that the flexibility operator **defines their own optimization strategy making use of the flexibilities offered to them on the one hand and on the other hand participating in new or existing balancing power markets on the other hand.** As such different levels / strategies of the flexibility concept can be considered and they are described in more detail in the generic use cases (WGSP-21xx).



### Overview of potential flexibility operator market roles

The following list of actor interaction with a flexibility operator is not intended to be exhaustive, but instead the descriptions offered here are intended to provide a general overview of the 'flexibility concept' and therefore is not a legal definition:

The suggested market roles and actions include the following and may represent commercial use cases:

- **Energy supplier** - sends different price signals to their customers in order to influence their consumption behavior. The customer might use the information and react manually or automatically.
- **Aggregator** – responsible for balancing their contracted position which they have in turn contracted with in a given bidding zone or DSO area/areas. In essence they pool flexibility in order to use them for technical or commercial use cases in the market or grid area, as outlined below:

#### Case of an aggregator

**CEM** (one or more) - is responsible for gathering flexibilities within the customer premises and providing them to a flexibility operator like an aggregator, and therefore does not directly participate in flexibility markets.

**Aggregator** - is responsible for summing up flexibilities from several CEMs and actively participates in markets or further commercial transactions.

As such the following high level activity sequence has been suggested

1. Get flexibilities from CEM's with load/generation/storage and market them
2. Activate flexibilities (e.g. smart start of appliances, industry loads, CHP, PV, storage and EV)
3. Billing of flexibilities (refund, penalties etc.)

Note: In exceptional cases it might be that major grid users (e.g. industry, DER, infrastructure, commercial buildings) acts directly as flexibility operator. Therefore, in this case the CEM and flexibility operator system are combined.

- **DSO** - is interested in equipment which can be controlled in order to stabilize the grid and optimize power quality. In the case where they either have direct contract to control a customer's load or have contracted with an aggregator, the DSO will send command signals based on legal or contractual preconditions. The reaction of the customer might be fiscal (i.e. paid for) according to these preconditions, but there might also be mandatory legal requirements (especially for a Feed-In Management of distributed generation) with or without revenue.
- **Agent, Energy Servicing Companies** is likely to provide energy management tasks in the name of the customer(s): e.g. negotiating congestion management, reaction on tariffs.

Currently the barriers for participating in these existing markets are high. Therefore, in order to incentivize greater demand side participation, classical DSM concepts provided by the energy supplier should be complemented by additional concepts in a new market design which close the gap between the small ratings of the individual flexibilities and the market places (refer to UCMR, use cases e.g. RWE-0001, DKE-0010, SEC-0001, FINS-0115 / 117, INTEG-0007).

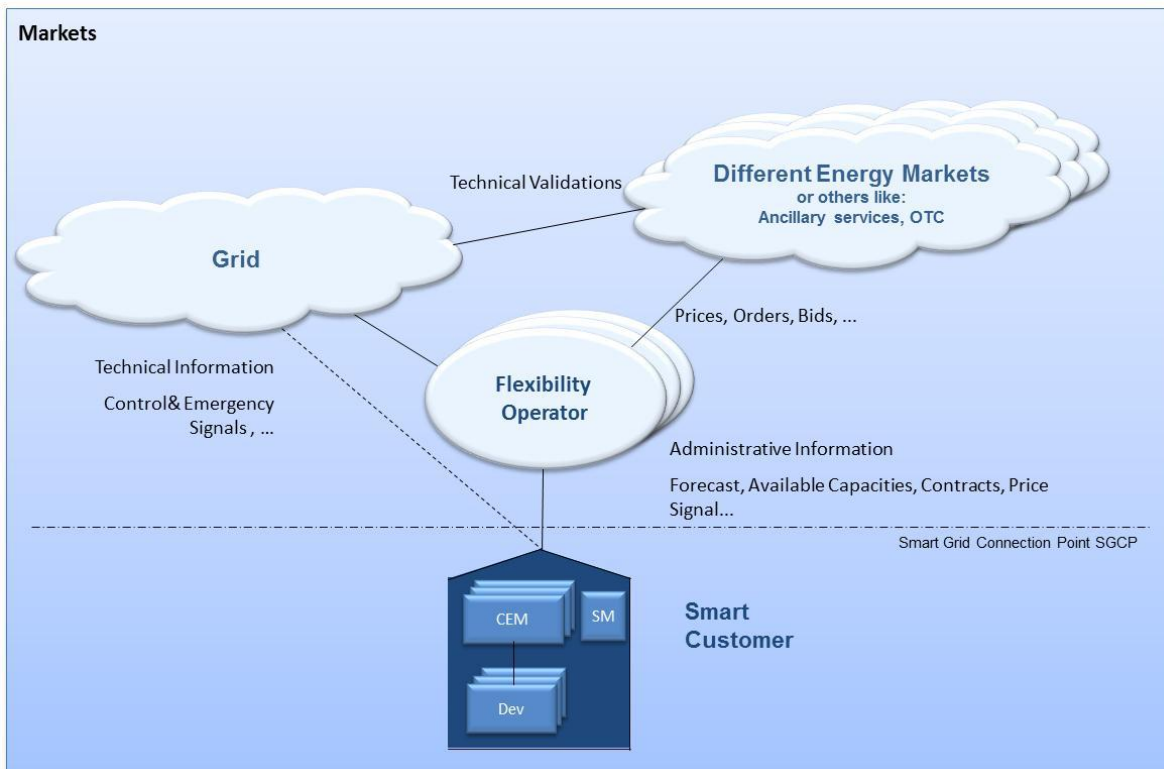

**Figure 22 – Flexibility operator gathering flexibilities from different CEMs and sells them to markets**

### 8.2.3.7 Open issues which are still under discussion

The following key issues have been captured and remain under discussion at the time of writing this report. However, their implications are worthy of consideration and are explored briefly within this sub-section.

#### Consideration of technical limitations in the grid (applying the aforementioned traffic light concept)

A number of the use cases provided encouraged the careful consideration of the spectrum of possible violations of technical limitations or power quality at both local / regional level (e.g. overload of lines during “happy hour” prices). Although it was also suggested that market design should be based on the principle that large liquid wholesale energy markets are efficient and that balancing and grid constraints etc. are strictly imposed from the beginning which then create other markets for services such as the case in the Smart Grid and smart market. In order to promote efficient investment in the systems enabling flexibility it is important for flexibility operators to be allowed to access multiple markets. It was also suggested that the rules governing these interactions need to be clear. Therefore a variety of different use cases for congestion or capacity management / markets have been suggested:

- Distinction of market / price processes and technical limitations

Flexibility use cases can be split into both commercial and technical categories (ENNET-0016/18 referring to them as Commercial Virtual Power Plant (CVPP) and Technical Virtual Power Plant (TVPP), similar: e.g. MOMA-0002, PMA-0002, INTEG-0004, MER-0001). However, the question of whether flexibilities can be offered to different markets simultaneously and how use cases can help bring clarity to the range of possible interactions with different markets is one which need to be clarified further and perhaps discussed via an expert group.

- Combined consideration of commercial activities and technical limitations (e.g. DKE-0010/0026)

A number of the use cases provided suggested that this issue needs to be differentiated based on the products which will be merchandized: e.g. wholesale market – no location considered, special ancillary services – geographical information of the products offered needs to be considered.

The following description (provided by [29], [30]) represents one such example of a use case which had been described in similar ways in several use cases:

Quote

*After the market gate closure, the aggregators [SG-CG/SP: flexibility operators] send their Active Demand (AD) [flexibility] program to the DSO. The DSO verifies the technical feasibility of the AD program on the distribution grid. If the amount of power involved is significant, the DSO aggregates the distribution network situation at the connection point with the TSO and sends this situation to the TSO for verification. TSO verifies the technical feasibility of the AD program on the transmission grid. The assessment is basically made by means of a load-flow calculation, carried out taking into account both the AD actions and the scheduled/ forecasted operation of the grid. If the assessment results in the violation of some constraints in the network, the system operator (SO), i.e. either the DSO or the TSO depending on the case, will first look for a possible solution that it has at its hand. If the SO cannot find such solution, then it will determine “curtailment” factors for the AD actions that cause the violations. The curtailment factors are determined so as to minimize the curtailment of the traded AD products. At the end of the technical verification process the DSO sends to the aggregation function [SG-CG/SP: flexibility operator]: either an acceptance signal, if the foreseen AD actions can be fully carried out, or a curtailment factor, so that the aggregator can take the appropriate measures regarding its AD program.*

Unquote

Many concepts for commercial use cases still remain under R&D:

An additional issue requiring consideration is the fact that a number of commercial use cases still remain at the R&D stage.

- Concept of microgrids

One such example is the concept of ‘micro-grids’ (refer to WGSP-0400). A CEM or the flexibility operator system might act also as a microgrid which may operate in islanding mode. In this case the flexibility operator also has to provide some of the functionalities of a local grid operator in cases of islanding mode and to balance load and generation. In this sense the flexibility operator role is only a part of a microgrid operator.

- Cellular structure (R&D project “moma” / E-Energy as example)

Another future example is the case of where the flexibility operator may be a local cell which interacts also with the neighbor cells (other flexibility operators) in order to balance regional/local supply and demand. However, it is worth noting that this is not currently the case within certain market’s regulatory regimes. Various neighbor cells may implement some kind of swarm intelligence acting as a group by means of decentralized automation, just supervised by central control. One possible case of direct control of a large number of DERs and smart customers could be new decentralized automation concepts.

Further key considerations relating to system stability and political framework

A great deal of R&D is on-going in this field. First results from R&D projects are presented in the use cases collection which are also presented as a basis for discussion. Nevertheless, several open questions still need to be verified or even evaluated and tested, for example:

- Stability

Several measures to stabilize the grid are working together. In the past, the task of maintaining system balance was controlled due to the system inherent stability of large generation units and a well-defined set of

control and recovery actions. Power control like primary, secondary and tertiary controls is clearly differentiated by the respective time constants.

As discussed, in the future control of the grid will require to rely more heavily on statistical and probabilistic measures due in part to the expected proliferation of small embedded generation units which may cause system instability within specific parts of the network. To manage such challenges certain actions may be required to be taken in parallel and increasingly involving lower voltage levels which more closely involve the demand side. As the system can be considered as a control loop, stability functions will need to be defined. However, whilst the proliferation of DERs present system challenges, in certain instances it may be more economic in the future for DSOs to procure services from a competitive market based on management of DERs from operators in the market, respecting the physical boundaries of the energy system.

- Political framework

It is also important to note that a number of legislative initiatives are in progress such as those which focus on the definition of legal frameworks for initiating first steps towards a Smart Grid: national and European grid codes, national laws, and regulations. These will directly influence business cases and related use cases - also for a flexibility use / demand response. Examples: feed-in tariffs, legal obligation to provide services or to change supply patterns.

## 8.2.4 Recommendations

Based on the use case analysis, the work on conceptual descriptions and generic use cases, this report makes a number of recommendations which are presented in this section.

### 8.2.4.1 Auto registration of participating devices and customers

#### Auto registration CEM <to> flexibility operator

Subsequently the suggestion of the Smart Grid connection point which is defined by criteria and as it is expected that there are millions of these SGCPs, several use cases are demanding that there should be an automatic registration procedure and partly a kind of plug & play functionality for the technical registration and connection of all smart customers to their flexibility operators or other relevant market roles like DSO, energy supplier or energy services companies.

New Smart Grid market roles like an aggregator, which collects small energy flexibilities, need low transaction costs in order to achieve a valid business case. Use cases and standardization with automatic functionalities like auto-registration are a possibility for lowering these transaction costs (e.g. by reducing the engineering connection effort).

Similar to other ICT systems (e.g. registration of DSL connection) with auto registration, the CEM will provide and receive information to/from "Grid / Market". This information may include supported functionalities given the related contracts or technological possibilities (e.g. load shifting, reduction of generation or provision of reactive power). Further information exchange during auto registration may include: contract details (legal/billing relevance), power ratings, available status information, geographical information, SGIS information like credentials and authentication, time synchronization and others.

Relevant contract details are to be dealt with in advance of auto registration.

Auto registration is itself seen as use case, WGSP-2130.

#### Auto registration smart devices <to> CEM or to SGCP

Also within the Customers Energy Manager (CEM see 8.2.2.1 above), auto-registration and "plug & play" functionalities should be applied in order to ease the use of smart devices and to convince the customers to participate in the Smart Grid. In case the CEM is part of the smart device, this registration might be limited to linking in-home devices to the home gateway (Energy Management Gateway or Smart Metering Gateway).

Also the CEM might exchange the required information of the smart devices and aggregates them towards the flexibility operator or other relevant market roles.

In case of multiple smart devices one CEM may perform the registration towards the grid / flexibility operator. Alternatively the internal CEM's of the smart devices may individually register to the grid / flexibility operator directly (refer to examples provided in Figure 17).

This auto registration is not part of the Mandate M/490, but it is logically interrelated with the interface to the flexibility operator or grid.

#### **8.2.4.2 Recommendations from commercial / grid area**

The transformation of the energy system towards a lower carbon, smarter system brings about a number of practical and technical challenges and thus requires more sophisticated and responsive approaches to communication. This brings with it the need for interoperable standards to promote a consistent approach to interfacing and integrating with current and future actors within the smart market. However, in acknowledging the need to follow such a direction, regional variation in legislation, such as national grid connection rules and network codes will need to be carefully considered within standardization processes. Therefore, a clear need exists for clear co-ordination and alignment between work being undertaken by EG3 and in the area of network codes. Important linkages exist between the elements of market model design, network codes and standardization which could be identified, collated and acted upon via a common expert group focusing on the development of market use cases which can help direct standardization activity within this field.

Although there are very different markets, discussions should take place to see if there is the possibility for both a generic market design and a generic market participation use case.

The problem for different price systems is that the same rule applies for different price and/or tariff schemes. On one hand it is expected that the energy suppliers are as innovative and competitive as possible in the liberalized market, inventing new "products" (tariffs, energy supply schemes, CO<sub>2</sub> emission reduction optimization, special energy service contracts, etc.) for energy supply which might include flexibility concepts. On the other hand standardized interfaces are required so that all participating market partners (particularly the CEM and smart devices) automatically understand any new tariff schemes or prices. These tariff arrangements should be as flexible as possible within practical limits. However, it is important to note the need from appliance manufacturers for standardized arrangements so as to ensure participation and interoperability within a smart market context, thus avoiding an appliance being stranded or 'losing its smartness' upon a 'change of supplier' scenario, or change of geographic location. Use cases can play an important role in engaging diverse groups of stakeholders around the need to encourage interoperability and in helping to define suitable standardized arrangements.

### **8.3 Conceptual description - Smart Charging**

#### **8.3.1 Introduction**

Besides analyzing the received use cases, this paragraph will also define a conceptual model in which the received use cases can be plotted. This model is based on literature concerning current Electric Vehicle (EV) pilots / initiatives and experiences. The concept of smart charging is further elaborated, since it helps clarify the relationship between motivations, goals and roles.

#### **8.3.2 Analysis of received smart charging use cases**

Most of the collected and analyzed EV related use cases (in total 41) are of a very high level. Most of them only describe a possible procedure and only a few are based on real experiments or pilot projects. Approximately half of the use cases are based on demonstration projects and on real results. 25 use cases did not use the template and 16 did use it.

The relationship to Smart Grids is in almost any case only an indication that this is a possibility, sometimes only for load shifting and in other cases for load control. Mostly for optimizing the upstream energy system like peak shaving, congestion management or integrating renewables. Therefore EV can be part of other high level use cases like VVO or DR (flexibility).

The EV related use cases can roughly be divided into 5 categories based on use cases received:

1. WGSP-1100 Uncontrolled charging
2. WGSP-1200 Charging with demand response
3. WGSP-1300 Smart (re- / de) charging
4. WGSP-1400 Ensuring interoperability and settlement
5. WGSP-1500 Manage charge infrastructure

### 8.3.3 Conceptual model

In this chapter further attention will be given to the smart charging concept, since it concerns a concept that has not been discussed previously in the report. The other concepts are either covered in chapter 8.2 about the flexibility concept (incl. DR). Interoperability and settlement are not really a part of the Smart Grid concept, but are preconditions. This also applies to the Charge Infrastructure Management System. For this reason this chapter will refer to the use cases and will not go into the details here.

The smart charging use case will be used by the SG-CG/SGIS to evaluate the security toolbox and to enhance the privacy and security requirement use case. The same use case will also be used by SGTF-EG2 to serve as an illustrative example for the data privacy impact analysis template in their report.

To be able to work out the use cases, the first step is to establish a conceptual model for the field of EV charging and the mapping of the use cases to this model. In the figure below, the field of EV charging is broken down into different areas:

- Charge station services: This includes everything related to an EV that wants to charge at a charging point. Standard charging (plug in and “just charge”) leads to the use case “WGSP-1100 Uncontrolled charging”. Demand response and price signals leads to “WGSP-1200 Charging with demand response” and Smart charging leads to WGSP-1300 through all kinds of motivations that are described below.
- Provisioning<sup>25</sup>: Once an EV connects to a charge point, it has to get authorized and authenticated to charge. Provisioning concerns this step in the charge process.
- Interoperability: This concerns interoperability between EV’s and charge points, not only from a technical point of view, but this also concerns “roaming” (term from the area of mobile phone communication). An EV should be able to charge at any charge point from different charge point operators, in different countries etc.
- Payment and billing services: When an EV is charged, it has to pay for this. This has to be “handled” in some way (“settling”).
- Auxiliary services: This can be all kinds of services related to charging and smart charging, like route-based or location-based information services, reservations, energy efficiency optimization, CO<sub>2</sub> reduction mechanism etc. for EV users (e.g. nearby charge point locations).

---

<sup>25</sup> fulfilling preconditions before providing a service, here: charging, e.g. security/data privacy issues like access rights

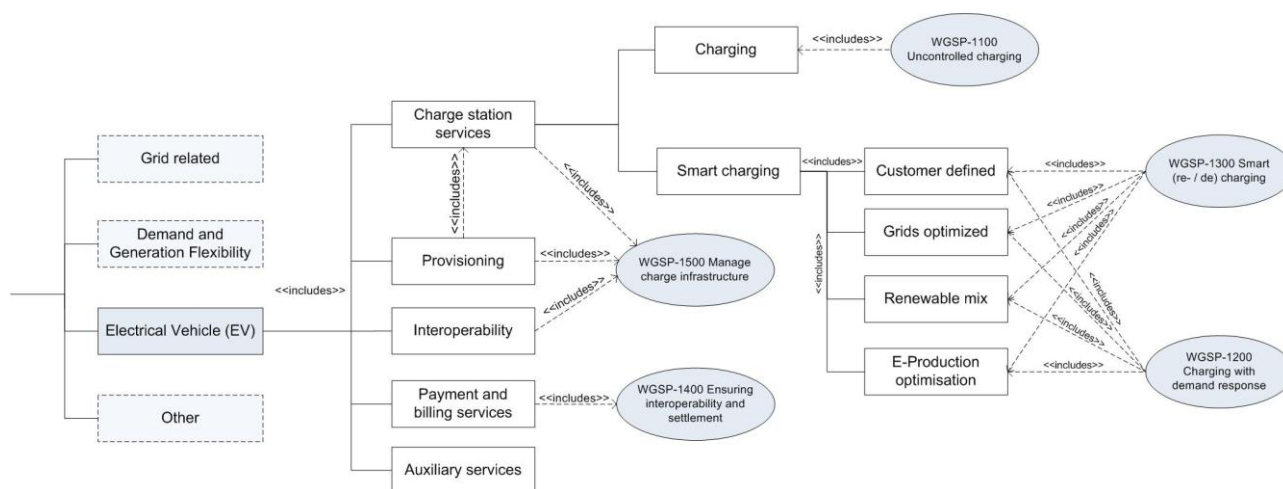

**Figure 23 – EV charging overview**

Uncontrolled charging is the basic form of charging EV's. In this way of charging the charge process is not externally controlled. This is also called “dumb” charging, which can be done in different ways at different locations. The aim is simply to recharge at any location where necessary. This can, for example, be done at individual domestic charge points using standard sockets, using sophisticated home chargers (power charging) or at shared or public charge points.

The smart charging<sup>26</sup> concept is split into different requirements why it should be done and what kind of problems it solves:

- Customer defined charging: The chief aim for smart charging is to maximize consumer convenience (facilitate EV users, optimize charging conditions and respect customers needs and requirements) through the use of available infrastructure (grid connected charging stations). To facilitate the EV user, smart charging should include the customer needs.
- Grid optimized charging: The construction of the EV infrastructure must be done within the available grid capacity and to avoid unnecessary grid investments. Since the grid has limited capacity and can have voltage constraints, optimization is used to prevent grid failures or power quality issues, using load control (eventually with use of (fixed) storage systems or vehicle to grid (V2G)).
- E-Production optimization: This concerns optimization (cost-effectiveness) of electricity production (peak shaving) and avoiding unnecessary investment in production capacity, using load control (eventually with use of (fixed) storage systems or vehicle to grid (V2G)).
- Renewable mix charging: This is related to all forms of smart charging (customer defined, grid optimized and E-Production optimization). In the first phase, when EV's are mainly used by “early adopters”, it can be expected that charging from RES is welcomed by this group of EV users.

The above 4 different requirements are related to the whole chain from energy supply via the transport and distribution networks and the charge station to the EV.

Use case WGSP-1200 describes demand response with signals. The idea is to use price signals or other incentives to influence the customer. This also implies that the customer should be able to respond in some

<sup>26</sup> Smart charging in this paragraph also concerns de-charging.

way. Signals can be based on factors concerning grid optimization, RES, E-production optimization or customer wishes. Please refer to chapter 8.2 for more information about demand and generation flexibility.

For smart (re-/ de) charging (use case WGSP-1300), in the picture below, the chain from energy supply to EV is schematically displayed. Each node in the chain is related to (at least) one of the requirements.

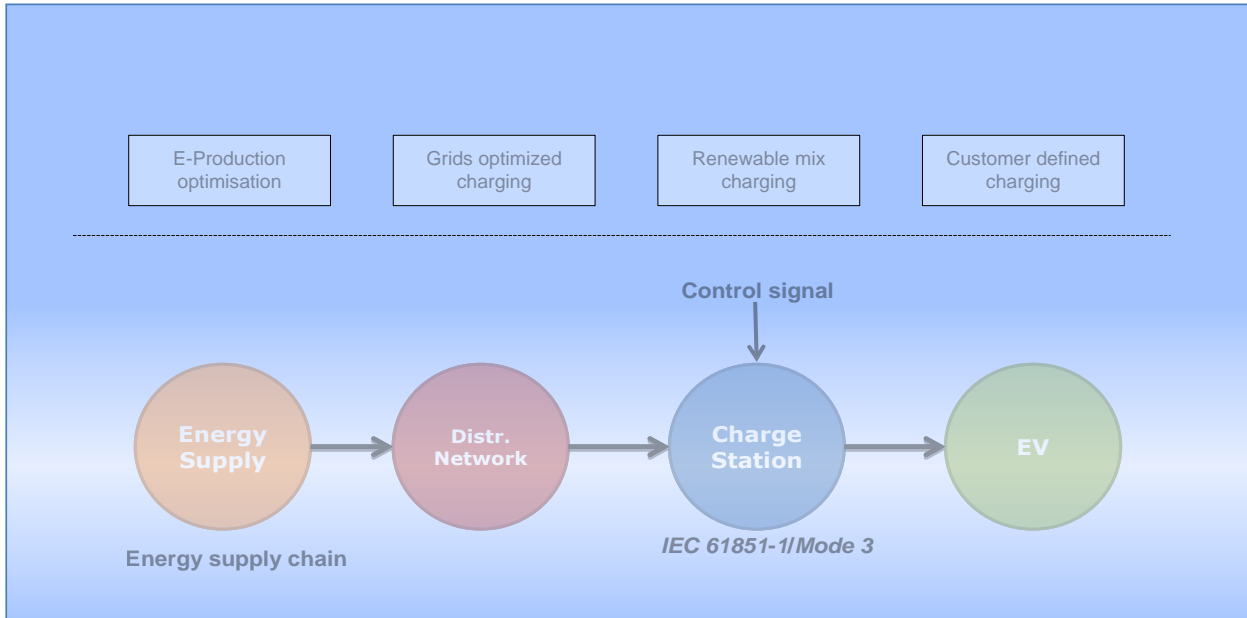

**Figure 24 – EV Charging Supply Chain**

This visualizes that constructing an EV infrastructure and developing related procedures for the charging of electric vehicles is a complex task. Sometimes the optimization have to consider conflicting objectives. As previously indicated, the chief aim is to maximize consumer convenience (facilitate EV drivers) through the use of available infrastructure (grid connected charging stations), moreover construction of an EV infrastructure must be done in a cost-effective way. This also means balancing the energy demand (charging requests) with available supply and grid capacity so to avoid unnecessary utility and grid investments. In addition it should also achieve the goal of a low-carbon EV mobility solution. RES, which are both centralized as well as decentralized, should be integrated.

By taking control of the charging process, one can optimize the use of the grid and available energy to minimize additional investments, and facilitate the integration and storage of renewable energy (RES) – which is known as ‘smart charging’<sup>27</sup>.

In an EV charging supply chain the following actors are identified: the Energy B2B-market, DSO, CSO, CSP and the EV (Figure 25). The charge station operator (CSO) operates the charging stations. An EV connects to a charging station to charge the car battery. The DSO manages the distribution grid. The charge service provider (CSP) supplies charging services.

It is also important to facilitate a free market model for the actors in EV charging supply chain. An EV customer must be able to select a CSP that offers EV charging services/options tailored to its needs/convenience. For example, a customer has preferences for RES, lowest price, maximum charging times etc. This example concerns “Smart charging services” in the “market” between EV and CSP. Besides this, on other levels services are provided as well. The actual charging between EV and CSP can be considered as a service in the network level (charging infra operations). The DSO provides a system service when charging. These different levels of services are visualized in the scheme below.

<sup>27</sup> Proposed originally by EURELECTRIC



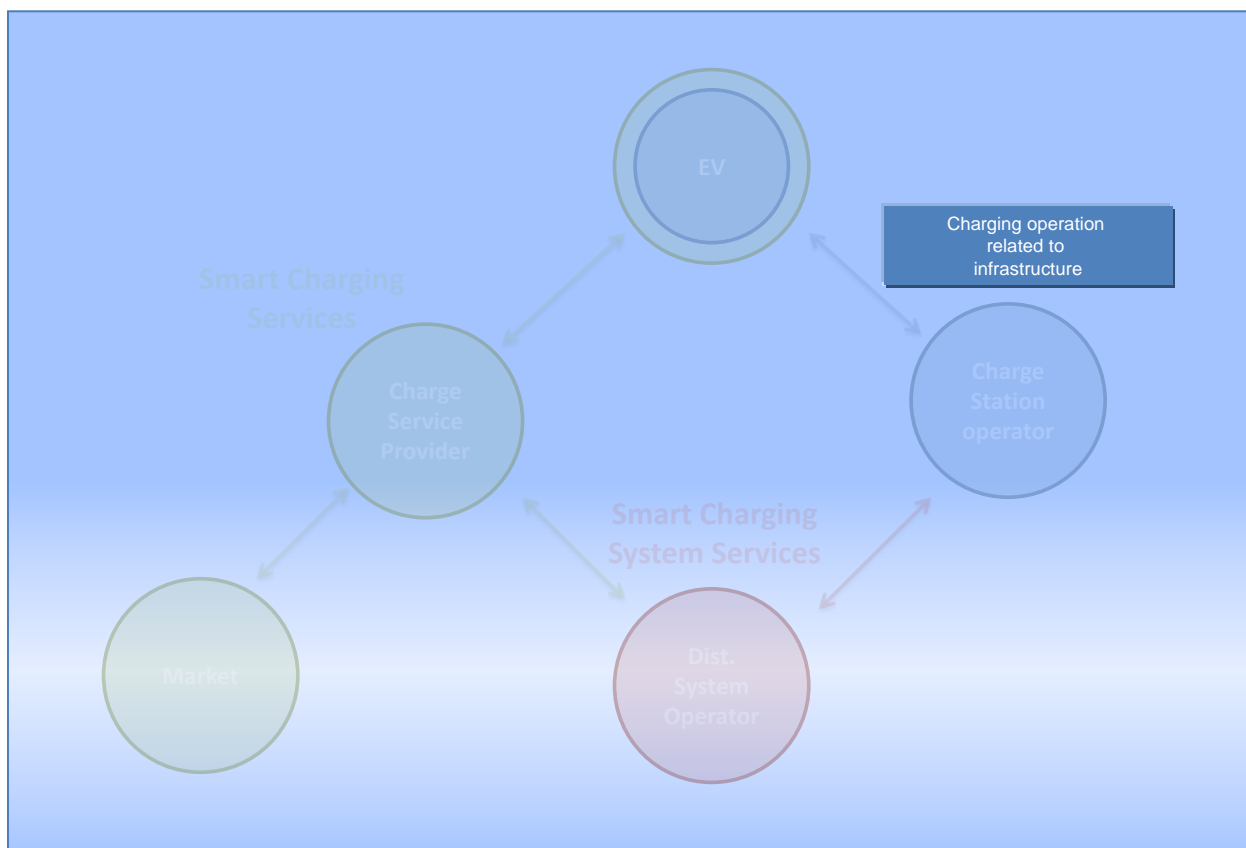

**Figure 25 – EV charging infrastructure**

The system service provided by the DSO includes local capacity management, handling emergencies (grid overload), balancing and local forecasting. In most situations grid capacity should not be a obstructive issue, in some cases problems can be avoided by being smart and in some cases the DSO is responding to emergency situations. This all depends on multiple variables. The interaction between grid and market can best be captured using the traffic light concept shown earlier.

The use case “WGSP-1400 Ensuring interoperability and settlement” includes payment and billing services. Handling payments and settling can be done in a variety of ways, such as mobile billing i.e. Radio-Frequency Identification (RFID), Mobile Phone, and Credit Card systems. The settling is part of this use case. Furthermore, customers of different CSP’s should be able to use different charge points and should not be bothered with settling between actors. This requires interoperability between actors, locations, countries etc.

Besides managing charge station *services*, the hardware involved should also be managed. This aspect of E-mobility is included in use case WGSP-1500 “Manage charge infrastructure”. Managing the infrastructure involves tasks such as keeping the charge points operating and up to date. It also includes provision which is defined in the above text as identification of customers, authorization and authentication. Transactions that are performed should be exchanged between different actors. The infrastructure involved enables communication for load management (flexibility).

## 9 Generic use cases

Generic use cases (GUC) are provided in the Use Cases Management Repository (UCMR, [26]). These GUC are originated from different sources:

- The Working Group “Sustainable Processes” (SG-CG/SP) suggested the generic use cases based on an analysis of the use cases collected. In general these use cases are more related to expected future Smart Grid use cases
- The Working Group “First set of standards” (SG-CG/FSS) provided suggestions for GUCs in relation to the description of systems within their report. These GUCs, which are more or less describing important state-of-the-art functionalities, will be added to the UCMR with a short narrative description and might be further detailed by experts when needed. Please refer to [23].
- The Working Group “Smart Grid Information Security” (SG-CG/SGIS) will provide GUCs in the field of information security, reviewing their already supplied use cases which had been provided during the collection phase.
- The Working Group “Reference Architecture” (SG-CG/RA) is working on additional use cases which had been analyzed for the reference architecture work and might complement the set of generic use cases.
- In parallel to the SG-CG, the Smart Metering Coordination Group (SM-CG) is working on a set of smart metering use cases which will be added as generic use cases as soon as they are finalized.
- In future the set of collected use cases might be reviewed again by technical committees when detailing use cases. Therefore further use cases provided during the collection might be considered as generic use case.

The use cases described in the reports should be seen as a kind of snapshot, because the work is on-going. The latest information will be provided in the UCMR<sup>28</sup>.

In the following only the SG-CG/SP use cases are further described (Figure 26).

Structuring of the GUC has to be updated according to the general discussion leading to the description in chapter 6.5.3. Further alignment with SG-CG/FSS is needed to prepare an overall structure of all generic use cases suggested so far.

---

<sup>28</sup> For a summary of all currently described generic use cases, please refer to the Use Cases Management Repository (UCMR [26]). Additionally, Generic use cases related to the Mandate 441 Smart Metering are currently under development in the Smart Metering Coordination Group [8].

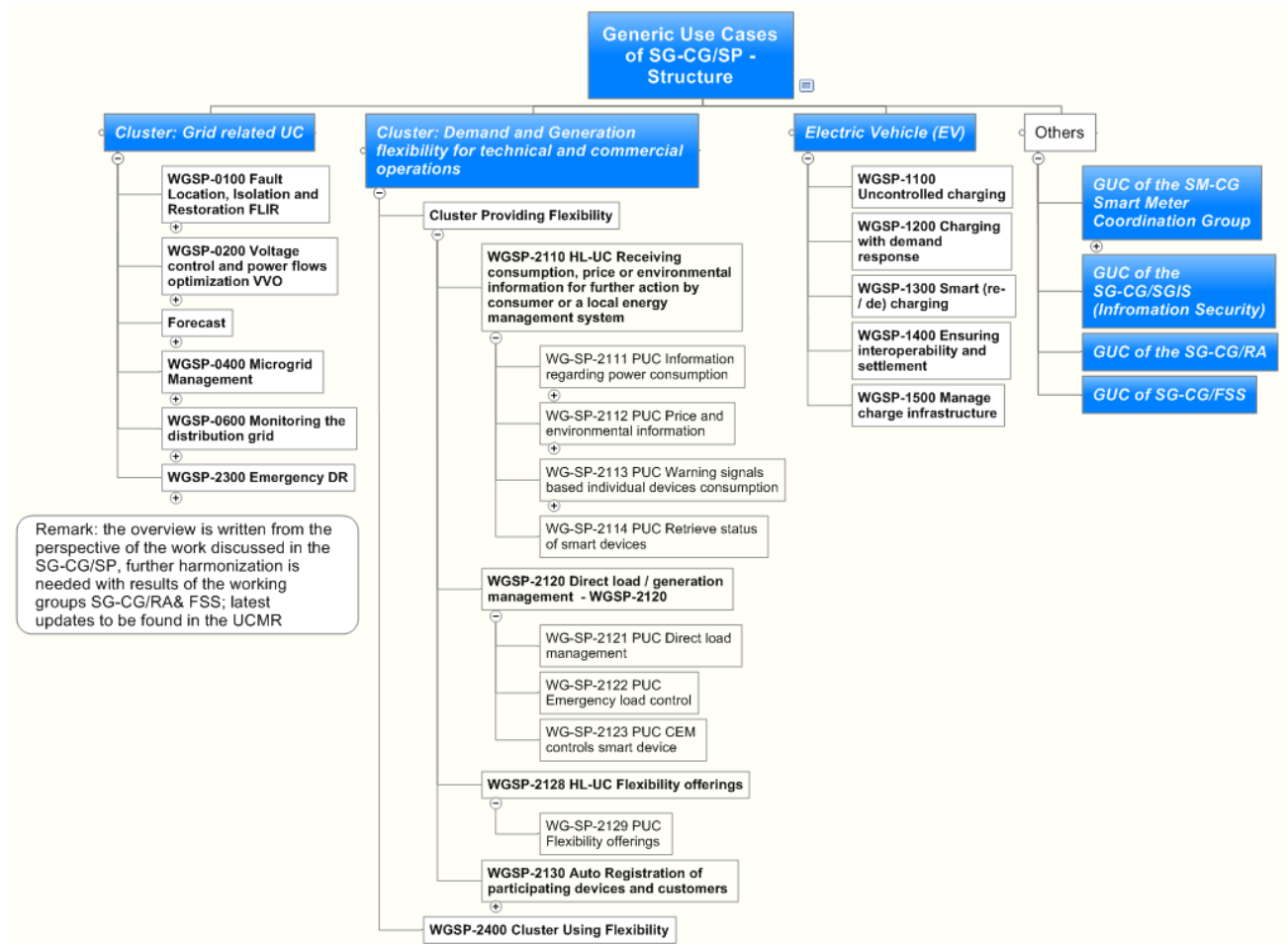

**Figure 26 – Generic use case of the SG-CG/SP - Structure**

Roughly the use cases have been sorted according to the following clusters:

- Grid related use cases

Keywords: Monitoring, further automation for grid stability (e.g. FLIR, VVO see below), especially decentralized functionalities

Several use cases are describing existing functionalities, here especially coming from power automation, network operation and monitoring (SCADA). Those use cases are well known today, but have to be adapted to the Smart Grid in order to realize spreading of intermittent power sources (generation or storage) at any level of voltage. These technologies are now being introduced at lower voltage levels, whereas they are used today mainly in the transmission grid or on higher voltage levels<sup>29</sup>.

- Flexibility use case (refer to the conceptual description)
  - Providing flexibility: DER, active customers/active load

<sup>29</sup> Mostly these use cases are considered in IEC/TC 57, [www.iec.ch/tc57](http://www.iec.ch/tc57). Further use cases in the area of DMS and others are developed or under development by TC 57, e.g. IEC TC57 WG 14 is in charge of System Interfaces for Distribution Management (SIDM), see IEC 61968-1 describing the interface reference model for Distribution Management. Refer also to report SG-CG/M490/B [22]

- Using the flexibilities for markets, services or grid operation
- Smart charging use cases (refer to the conceptual description)

The WGSP generic use case can be linked to the provided use cases. This is documented in the UCMR and the following table shows an example.

**Table 1 – Example of the mapping of generic use cases to the use cases received during the collection**

Generic use cases – structure	Use cases of the collection which are considered for the generic use cases
<b>WGSP-0100</b> Fault Location, Isolation and Restoration (FLIR)	TC57-0001, W2E-0002, FIN-0002, FIN-0004, ETSI-0004, ON-0014, ON-0015, FINS-0006, ENER-0005, ENER-0007
<b>WGSP-0200</b> Volt Var Optimization (VVO)	ENNET-0015, RSE-0001, DKE-0001, DKE-0003, FNN-0004, MOMA-0001, ON-0017, FINS-0003, FINS-0019, FINS-0020, FINS-0021, FINS-0022, FINS-0023, ENER-0009, ENER-0022, TC205-0047, DKE-0025, RWE-005, RWE-006, RWE-007, ENEL-0003, ENEL-0004
<b>WGSP-0400</b> Microgrid management	FINS-0015, FINS-0031, FINS-0033, FINS-0040, FINS-0041, ENNET-0014
- Islanding trigger	
- Actions for changing from normal operation mode to islanding mode	FINS-0031, FINS-0033
- Black start in case of failure to island	FINS-0015
- Island operation	
- Reconnection to main grid	FINS-0031
- Microgrid services provisioning	FINS-0040, FINS-0041
<b>WGSP-0600</b> Monitoring the distribution grid	EDF-0012, FINS-0005, FINS-0034 - 0037, ENER-0004, ENER-0006, ENER-0013, ENER-0028, INTEG-0003, RWE-0003, RWE-0004, RWE-0008, FNN-0001-0009

This and the next chapters provide a short overview of the suggested SG-CG/SP generic use cases. The complete descriptions are available separately in the Use Case Management Repository (UCMR).

It also has to be stated that these generic use cases are not considered as complete, but they are seen as a first set of prioritized high level use cases for Smart Grids. Within the following discussion phase with the experts of the Smart Grid community further suggestions were included. Still further discussions are needed as the relevant TCs have to be involved in the next steps more deeply.

#### Recommendation

The suggested GUCs are seen as a starting point. New use cases should be related to the existing GUCs and the existing actor list as far as possible in order to keep the set of GUCs consistent.

## 9.1 Grid related generic use cases

### 9.1.1 Generic use case *Fault Location, Isolation and Restoration (FLIR)* – WGSP-0100

FLIR automates the management of faults in the distribution grid. It supports the localization of the fault, the isolation of the fault and the restoration of energy delivery.

The FLIR use case describes a control centre based implementation and is divided into four sequences:

1. Fault detection and clearance – The protection devices in the grid detect the fault and issue suitable breaker tripping.

2. Fault localization – Identify the physical location of the fault by analyzing the telemetered alarms received from protection devices in the grid.
3. Fault isolation – Determine switching actions which will isolate the faulty equipment(s) from the rest of the grid.
4. System restoration – Resupply those healthy parts of the grid, which are de-energized during the fault clearing, but considering safety issues.

### **9.1.2 Generic high level use case *Voltage control and power flows optimization (VVO)* – WGSP-0200**

This use case is related to the automatic control of voltage profile and power flows in active distribution grids with locally connected generators.

Voltage profile and power flows in active distribution grids change dynamically, mainly because of the stochastic production of renewable sources. The power injected by distributed generators can overload feeder segments or result in voltages exceeding limits in some parts of the grid. In order to guarantee the correct voltage value at each customer site, the voltage profile of the distribution grid is continuously monitored and optimized using the available network flexibilities.

Considering an area of the distribution grid, the optimization function computes the optimal settings of controllable generators, storage units, flexible loads and other deployed power equipment (e.g. tap changers, switched capacitor banks and controllable voltage devices) in the controlled area. The costs of control actions and load/generation forecasts in the area can also be taken into account in order to select the appropriate control strategy. In addition to voltage profile, the optimization function can also support other objectives (e.g. reduce grid losses, minimize feeder overloads, improve load/generation spatial balance) which can be changed at different times according to grid scenarios, operator requests, or other application triggers.

The optimization function can be implemented in a delocalized control center for the selected area. Considering the hierarchical architecture of distribution grids, control areas can coincide with sections of the grid underlying a substation and having one point of common coupling with a distribution bus or an upper level grid. In this case, the optimization can be performed by the Substation Control System, and the main voltage optimization criteria can be extended to supply ancillary services to the upper level grid, contributing to the stability of the electric power system. The function then improves the spatial reactive power balance, as well as voltage quality in electric distribution systems and the spatial balance of active power.

Depending on the particular grid control area where the voltage control is applied and on the optimization objectives, some generation/load units can be controlled either directly by the control center for the selected area or via the flexibility operator. The control actions will be based on legal or contractual preconditions between the customers and the supplier (or other market players such as aggregators, energy services companies). The reaction of the customer might be remunerated according to a commercial contract, but there might also be mandatory legal requirements with or without revenue.

### **9.1.3 Generic high level use case *Short term load and generation forecasting* – WGSP-0301**

The load and generation profiles are forecasted for a given period, for example the next day, according to weather forecasts, historic load and generation profiles, load and generation statistics, events (social, generation maintenance events...).

The distribution system operator has to forecast generation and consumption in order to monitor and plan operation of the distribution system for short term situations. In a similar way the flexibility operator has also to forecast generation and consumption at the premises of the consumers in its portfolio in order to forecast active demand and generation flexibility, prepare its offers to the market and/or the electricity system players and design the signals sent to the CEM.

Generation and consumption can be forecast within various time horizons with different precision. The required data are gathered from e.g. past statistics, planned up-times, prosumer vacation/travel times and maintenance schedules etc.

Non-variable generation from e.g. fuel generators, biogas, geothermal, or water turbines is more predictable than variable-output generation.

Forecasting of variable-output generation - from e.g. wind power or PVs - has to be based on the availability of DERs and numerical weather prediction data, which are then fed into statistical data modeling tools.

Consumption (Load) forecasts will be based on available information such as past consumer data statistics, expected/planned needs (daily, weekly and monthly periods, etc.), expected weather forecasts, vacation/travel times and storage level.

#### **9.1.4 Generic high level use case *Microgrid Management* – WGSP-0400**

A microgrid is a low-voltage and/or medium-voltage grid equipped with additional installations which aggregates and manages largely autonomously its own supply- and demand-side resources. Some microgrids may produce enough electric energy to meet the power needs of the users within the microgrid.

In special circumstances, the microgrid (part of the distribution grid) can be islanded in order to operate autonomously, providing electricity supply to its customers (or part of its customers under a specific contract) for a limited period of time.

#### **9.1.5 Generic high level use case *Monitoring the distribution grid* – WGSP-0600**

Once connected with a communication line the new Smart Grid devices and their communication possibilities (smart metering, substations) should also be used for better monitoring of the grid on lower voltage levels. This information will be provided in the SCADA system of the Distribution System Operator (DSO) and for further evaluation (e.g. fault identification, outage monitoring, etc.) and control. The increasing amount of DER providing energy to the distribution grid also on the lower voltage levels results in the need for better monitoring of, for example, voltage values or power ratings.

#### **9.1.6 Generic high level use case *Emergency Signals* - WGSP-2300**

For emergency situations in the grid the grid operator has a portfolio of options available in order to influence the situation (e.g. via reserve power). This use case describes the option to shut down consumption by intelligent load shedding via direct load management, if all other options have failed (see WGSP-2120 from the CEM perspective and respective individual contractual and/or legal preconditions like a grid code existing).

When grid energy production and consumption imbalance occurs due to either an unexpected demand increase or a sudden drop in generation, then immediate action must be taken.

In an emergency situation the grid operator requests

- demand power reduction of flexible loads, switch-off of controllable interruptible loads according to an intelligent load shedding plan to avoid abrupt uncontrolled load shedding and increase of power supply, e.g. by connected DER (Case: Demand exceeds supply).
- generation power reduction or disconnection, increase of flexible demand, e.g. Heat Pump (HP) (Case: Supply exceeds demand)

Moreover, the use case comprises the following functions:

- Load Shedding Plan Selection. Within the boundaries of this function the operator selects the most appropriate load shedding plan to execute according to the given time, severity and locality data of the critical situation.

- Load Shedding Execution. This function carries out the transmission of the proper control signals to consumers.

### 9.1.7 Generic use cases related to *Electric Vehicles charging* – WGSP-1000

Based on the use cases received, the EV charging related use cases have been divided into 5 categories:

1. WGSP-1100 Uncontrolled charging
2. WGSP-1200 Charging with demand response
3. WGSP-1300 Smart (re- / de) charging
4. WGSP-1400 Ensuring interoperability and settlement
5. WGSP-1500 Manage charge infrastructure

1. Uncontrolled charging

This category provides only the possibility for connecting the EV to the grid at different locations. The aim is to recharge at any location where necessary. Low power or high power AC and DC are foreseen. This implies no charge control. For further information, refer to IEC 61851-1 mode 1 and mode 3.

2. Charging with demand response

This category provides the possibility to connect the EV recharge at any place via EVSE (Electric Vehicle Supply Equipment) and / or with an additional special IEC-15118 compliant communication device. The extra communication makes it possible to receive price signals or other incentives so that a customer reaction is possible. This provides the possibility for demand response in the same way as for other loads connected to the grid.

3. Smart (re- / de)charging

Smart recharging provides a more controlled way of EV charging. This opens a real possibility for smart charging and even V2G possibilities based on flexible contracts and technical signals for load control. This can be realized via EVSE (Electric Vehicle Supply Equipment) and / or with an additional special IEC-15118 compliant communication device. For further information on load control, refer to IEC 61851-1 mode 3.

4. Ensuring interoperability and settlement

This use case describes interoperability related matters and settlement such as identification, billing etc. between different actors.

5. Manage charge infrastructure

This use case describes the complete system necessary for intelligent charge equipment management, including identification, status reports, malfunction management etc. and for supplying all information for smart charging and settlement.

## 9.2 Suggested generic use cases related to the flexibility concept

### 9.2.1 Generic high level use case *Receiving consumption, price or environmental information for further action by consumer or a local energy manager*- WGSP-2110

The objective of this use case is to exchange information between external actors and the premises in order to:

- Make consumers aware of their energy consumption
- Enable consumers or their Customer Energy Manager (CEM) to react on (changes in) energy prices or other signals
- Optimize consumption to use cheaper or greener energy (depending on personal preferences)
- Enable external actors to retrieve the state of in-home smart devices
- Keep consumption below a certain level

A combination of the functions described in this use case can be labeled as “Demand Response”.

This high level use case comprises four different primary use cases:

1. Exchange information regarding power consumption or generation
2. Exchange price and/or environmental information
3. Send warning signals
4. Retrieve status of smart devices

### **9.2.2 Generic high level use case *Direct load / generation management* - WGSP-2120**

Demand Side Management signals are sent to the Consumer Energy Manager (CEM) to trigger a program that manages load by interacting with a number of in-home smart devices connected to the CEM.

The objective of this use case is to manage in-home devices in order to control power consumption, generation or storage resources for example to avoid the risk of black out, react to real-time peak power signals, balance the load between consumption and local production, ...

This high level use case comprises three different primary use cases:

1. Load / generation / storage management
  - Scenario 1: A smart device has the final decision on its own load adjustment.
  - Scenario 2: Device has no control of its own load adjustment.
2. Emergencies
  - Scenario 1: Emergency load control
  - Scenario 2: Announce end of emergency load control
3. CEM controls smart devices

### **9.2.3 Generic high level use case *Flexibility offerings* - WGSP-2128**

The flexibility concept assumes that parties connected to the grid produce offerings of flexibility in load and (distributed) generation. Thereby, so-called flex-offers are issued indicating these power profile flexibilities. Flex-offers are dynamically scheduled in near real-time, e.g. in the case when energy production from renewable energy sources, such as wind turbines, deviates from the forecasted production of the energy system.

The objectives of this use case are the exchange of offerings of the use of flexibility in supply and demand with another party, negotiation of these offerings and activation.



This use case describes how two market roles negotiate (offer, accept and assign) about usage of demand or generation flexibility.

Flexibility offerings are sent from flexibility providers to one or more (potential) users of flexibility. The offerings state the available flexibility in the dimensions of time (when can production / consumption take place) power and/or energy (what can be produced / consumed) and finance (in return for what compensation).

These offerings are negotiated by a process of offering, accepting or rejecting, possibly followed by providing a different offering. Reasons for accepting and rejecting include suitability of the offered flexibility (the expected value of the flexibility in e.g. a portfolio) and financial aspects. The negotiation has to consider grid constraints as mentioned in Chapter 8.2.3.6 which explains the traffic light concept. Finally, after successful negotiation, the acquired flexibility is exercised by the acquiring party.

#### **9.2.4 Generic high level use case *Auto Registration of participating devices and customers* - WGSP-2130**

Considering the intention that in future millions of smaller DER devices and also households, buildings and industry should participate via a Customer Energy Manager (CEM), an easy integration of new devices or customers is an essential precondition for Smart Grids and Smart Markets<sup>30</sup>.

1 The CEM registers the abilities and flexibilities of connected devices (storage, load, generation) automatically and may forward the combined information towards a flexibility operator, the distribution system operator or relevant market roles.

2 New devices in a household or building may register themselves automatically in the Customer Energy Manager (CEM).

#### **9.2.5 Generic high level use cases *Using Flexibility* - WGSP-2400**

Possible generic use cases are already indicated in the conceptual description. These have to be worked out in the next steps together with expert groups in this field.

---

<sup>30</sup> For flexibility use cases (refer to WGSP-211x) just providing variable tariffs, the auto registration can be reduced to a kind of "Pairing" or "Auto-registration light" that means a simple connection of the CEM (central or single device) to the tariff system just receiving new tariffs.

### 9.3 Analysis of the SG-CG/SP generic use cases

As described in chapter 6.5.2 several mappings of use cases are possible. For the SG-CG/SP generic use cases some mappings are part of the use case template and partly mappings have been added for evaluation. The following is just showing some examples for mappings. As it was recommended to provide a general database approach for all kind of different mappings, these mappings have been introduced to the UCMR.

#### Mapping of the generic use cases to high level services

The former EG1 of the EC TF Smart Grids provided a list with high level services and functionalities. The following examples illustrate which generic use cases serve which high level services. Further details can be found in the UCMR.

**Table 2 – Examples: Generic use cases related to the high level services defined in the EG1 report of the EC**

ID-Number	Use Case Name	A. Enabling the network to integrate users with new requirements	B. Enhancing efficiency in day-to-day grid operation	C. Ensuring network security, system control and quality of supply	D. Enabling better planning of future network investment	E. Improving market functioning and customer service	F. Enabling and encouraging stronger and more direct involvement of consumers in their energy usage and management
	<b>EV Charging</b>	X	X	X	X	X	X
WGSP-1100	Uncontrolled charging	X	X				
WGSP-1200	Charging with demand response	X	X	X	X	X	X
WGSP-1300	Smart (re- / de) charging	X	X	X	X	X	X
WGSP-1400	Ensuring interoperability and settlement	X				X	
WGSP-1500	Manage charge infrastructure				X	X	

#### Mapping generic use case to Technical Committees

Having already emphasized the need to involve the technical committee in the next steps and to define in cooperation a “Coordinating TC” for a cluster of generic use cases or for single GUCs, Table 3 provides some first suggestions.

Beneath the traditional set-up of the TCs, IEC structured itself regarding Smart Grids in 2011, through IEC/TC 8 “System aspects for electrical energy supply”. TC 8 is to prepare and coordinate, in co-operation with other TC/SC’s, the development of international standards and other deliverables with emphasis on overall system aspects of electricity supply systems and an acceptable balance between cost and quality for

the users of electrical energy. Electricity supply system encompasses transmission and distribution networks and connected user installations (generators and loads) with their network interfaces<sup>31</sup>.

In 2011 Ad-hoc group 4 “Smart Grid Requirements” was created and 11 Domain Core Team (DCT) set up in order to cover all Smart Grid requirements. These domain core teams are responsible for gathering generic use cases and for coordinating other IEC TC’s work on these use cases. AHG 4 also created a team responsible for methods and tools for use case management. Following the adopted new work item proposal 8/1309/NP TC 8 created officially working group WG 5 “Methodology and Tools” and WG 6 “Generic Smart Grid Requirements”..

The DCTs are listed below:

1. Transmission Grid Management
2. Distribution Grid Management / Microgrid
3. Smart Substation Automation
4. Distributed Energy Resources (DER)
5. Advanced Metering Infrastructure
6. Smart Home / Commercial / Industrial / DR-Customer Energy Management
7. Energy Storage
8. Electric-transportation (ET)
9. Asset Management
10. Bulk Generation
11. Market

Note: Therefore the generic use cases provided by SG-CG/SP have been fed to the IEC/TC 8 DCTs for further alignment and internationalization of the GUCs.

Some general considerations regarding the mapping of TCs to generic use cases:

- Grid related use cases are mainly related to TC 57, as they are partly already considered there today, but IEC TC8 DCT2 should analyze and consolidate these use cases with other regional input.
- Use cases in the area of demand and generation flexibility: This is a major area which touches the responsibility of multiple TCs. Anyhow, a coordinating TC has to be identified.
- Electric vehicles: The new Ad-hoc group Smart charging (EM-AhG Smart charging) under the responsibility of the SG-CG and the new E-Mobility Coordination Group had been set up. Results of this report will be used further in this AHG, SG-CG/SP participated in the kick off meeting. IEC/TC 8 AHG 4-DCT8 will also analyze the electric transportation use cases.
- Smart Metering: Smart Metering Coordination Group / TC 13
- Security: SG-CG/SGIS, further involved TC and organizations are mentioned in the SG-CG/M490/D SGIS report [24]

The majority of TCs mentioned below belong to IEC and have mirror committees in CENELEC (if not mentioned differently).

---

<sup>31</sup> Refer to scope of TC 8: [http://www.iec.ch/dyn/www/f?p=103:7:0:::FSP\\_ORG\\_ID:1240](http://www.iec.ch/dyn/www/f?p=103:7:0:::FSP_ORG_ID:1240)

**Table 3 – Mapping of generic use cases to involved Technical Committees**

ID-Number	Use Case Name	Suggestion for a coordinating Technical Committee (TC) ( <u>underlined</u> ) and involved TCs
	<b>Cluster: Grid related use cases</b>	
WGSP-0100	FLIR	IEC and CLC: <u>TC 57</u> , TC 8(X) IEC: TC 95
WGSP-0200	VVO	IEC and CLC: <u>TC 57</u> , TC 8(X), TC 77, TC 85 (X)
WGSP-0301	Short term load and generation forecasting	IEC and CLC: <u>TC 57</u> , TC 13, TC 8(X)
WGSP-0400	Microgrid management	IEC and CLC: <u>TC 57</u> , TC 8(X)
WGSP-0600	Monitoring the distribution grid	IEC and CLC: <u>TC 57</u> , TC 13, TC 8(X)
WGSP-2300	Emergency Signals	IEC and CLC: TC 8 (X), <u>TC 57</u> , (TC 13), TC 59(X), TC 61
	<b>Cluster: EV Charging</b>	IEC and CLC: TC 69(X), TC 57, TC 13, TC 8(X) ISO TC 22 CEN 301 CEN/CENELEC/ETSI: EM-AhG Smart charging IEC/SMB SG 6 Electrotechnology for mobility
WGSP-1100	Uncontrolled charging	IEC and CLC: TC 69(X), TC 57, TC 8(X) CENELEC 205 CEN/CENELEC/ETSI: EM-AhG Smart charging
WGSP -1200	Charging with demand response	IEC and CLC: TC 69(X) TC 13, TC 8(X) CEN/CENELEC/ETSI: EM-AhG Smart charging
WGSP-1300	Smart (re- / de) charging	IEC and CLC: TC 69(X), TC 57, TC 13, TC 8(X) CENELEC 205, CEN/CENELEC/ETSI: EM-AhG Smart charging
WGSP-1400	Ensuring interoperability and settlement	IEC and CLC: TC 69(X), TC 13, TC 8(X) CEN/CENELEC/ETSI: EM-AhG Smart charging
WGSP-1500	Manage charge infrastructure	IEC and CLC: TC 69(X), TC 13, TC 8(X) CEN/CENELEC/ETSI: EM-AhG Smart charging
	<b>Cluster: Demand and generation flexibility</b>	
	<b>Cluster: Providing flexibility</b>	IEC and CLC: TC 57, TC 8 (X), TC 13, TC 59(X) <u>CENELEC TC 205</u> IEC PC 118
WGSP-2110 (including WGSP-2111 to 2114)	Receiving consumption, price or environmental information for further action by consumer or a local energy management system	IEC and CLC: TC 57, TC 8 (X), TC 13, TC 59(X), TC 61 CENELEC TC 205 IEC PC 118
WGSP-2120 (including WGSP-2121 to 2123)	Direct load / generation management	IEC and CLC: <u>TC 57</u> , TC 8 (X), TC 13, TC 59(X), TC 61 CENELEC TC 205 IEC PC 118
WGSP-2128 (including WGSP-2129)	Flexibility offerings	IEC and CLC: <u>TC 57</u> , TC 8 (X), TC 13, TC 59(X), TC 61 CENELEC TC 205 IEC PC 118
WGSP-2130	Auto-registration	IEC and CLC: <u>TC 57</u> (for registration towards FO), TC 13, TC 59(X) <u>CENELEC TC 205</u> (inside home)
(WGSP-2400)	<b>Cluster: Using flexibility</b>	IEC and CLC: TC 8 (X), <u>TC 57</u>

## Mapping to the Smart Grid Architecture Model (SGAM)

It has to be mentioned that the collection of use cases and the current template used in the UCMR is using a domain definition according to TC 8 above. In parallel the SGAM was developed in SG-CG/RA. So in future use cases will additionally be linked to the SGAM and the existing GUCs have to be aligned with the domains and zones as defined in the SGAM (refer also to Annex B).

## **10 Description of the Use Case Management Repository (UCMR)**

With a large number of use cases from many different authors and different institutions the complexity in creation, administration and usage of use cases increases. Use cases are interlinked with each other and consider various documents, for example projects or input from national/international committees, which additionally increases the complexity.

To develop and manage use cases, a consistent framework – as elaborated by this group – for creation, classification, later retrieval and analysis has to be provided. The consistent usage of these mechanisms requires also a large manual effort including checking existing entities, adding new ones to a central list, administrating an overview of existing use cases and so on. Having a larger number of use cases makes these tasks likely to introduce redundancy as well as errors and makes a kind of quality assurance necessary.

Information technology (IT) is seen as a support mechanism to cope with these issues and can assist in the creation, administration and presentation of use cases. In the course of the work within this group, a first prototype IT tool has been developed in a joint project led by DKE together with OFFIS and IBM in order to support the work of the SG-CG/SP.

### **10.1 Necessary IT support**

In order to support the use case management, a web-based tool approach was chosen. The Use Case Management Repository is built on “Chronos Web Modeller” which is an open source tool that is freely available and has already proved helpful to support use case development within two German Smart Grid projects under the guidance of IBM. The implementation was done by OFFIS based on the further developed IEC/PAS 62559 template and the modifications worked out by SG-CG/SP. Both define the central data model for the tool.

This choice enables world-wide access, collaborative editing and furthermore avoids software installations on individual computers, which often comes along with license fees and administrative issues, especially in corporate environments. By following this approach, it is aimed to allow as many people as possible to become involved in use case creation and to provide the gathered information to a large audience.

Use case data are stored in a central repository along with associated artefacts such as actors, technical requirements and references to source-documents. This enables an easy linkage between related entities (Figure 27).

This fact also provides the possibility to assist users in use case creation insofar that required information, as needed at some points within the template, can be provided (e.g. actors, selection lists for domains or level of detail). Moreover the centralized collection of artefacts in a central repository only requires a single point of maintenance (for data and the application itself) and allows a cost-effective operation.

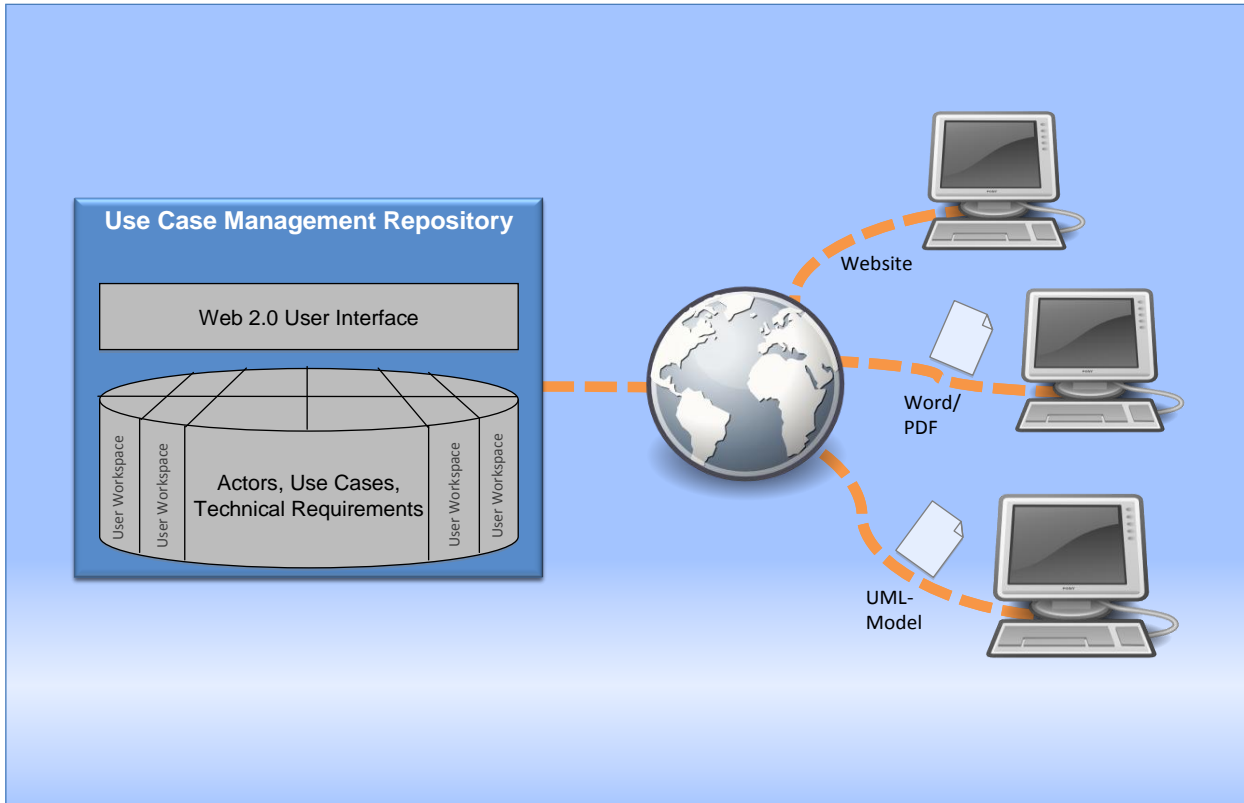

**Figure 27 – Use Case Management Repository (UCMR) - Overview**

Regarding work with multiple users, particularly in the use case creation phase, a multi-user concept was implemented in order to prevent concurrent overriding of data. In addition, a version history allows tracking changes made to data entities. As different users are interested in different parts of the use case, different views have to support their concerns. To deal with this, the working group developed three templates that differ in their level of detail; those aspects are also partly reflected in the tool to ease use case creation.

Additionally the tool offers the opportunity to classify use cases using a given, consistent vocabulary as well as keywords. One major advantage at this point is – in comparison to a template written e.g. in a word processor – that default selections are offered so that no mistyping can occur. Furthermore, changes and additions in this context can be consistently made at a single point.

Due to the electronic data acquisition based on a structured formal model, entered information can be extracted and transformed into various output formats. Currently, use cases can be exported in the form of documents (OpenOffice.org, Word and PDF) and UML models<sup>32</sup>. In particular the UML machine-readable format provides added value for further exploitation in external tools. Defined use cases can so serve as a basis of, for example, industry-specific use cases, test cases and especially be input for model-driven development.

<sup>32</sup> The models exported are UML 2.0-compatible and serialized using the XML format (version 2.1) using a specific profile extending the UML concepts. The exported XML files are created using the Eclipse Modeling Framework and were successfully tested to be imported into Sparx Systems Enterprise Architect (version 8).

The UCMR/Chronos UML-profile serves as the basis for the description of the UCMR-created artefacts. It extends UML use cases as well as UML actors and defines additional UCMR-specific concepts based on UML classes which are associated with use cases.

## 10.2 Collaborative editing process

The process of use case collection and harmonization is also supported with a first simple implementation. Each user is provided with a personal workspace where use cases can be edited individually. To collaboratively work on use cases, the tool provides additional workspaces for groups and as a reference repository. Users are free to create new use cases, actors and other related entities in their own workspace and reference entities from other (non-personal) workspaces. Special window elements can be used to display and edit relations to other use cases and used entities.

When an individual user finishes his/her work on a use case, it can be transferred to one of the group workspaces. In addition to just collaboratively creating a use case, they can be utilized for quality assurance and harmonization tasks by a group of people. After finishing this step and validation (refer to chapter 6.6) the use case and related artefacts can be moved by the person responsible to a selected workspace that is to be used for reference and publication.

## 10.3 Outlook for future additions

Within the given timeframe and the current status of the tool, it can be said that it covers many aspects of collaborative use case development in the standardization area that became apparent up to now. Nevertheless, the tool developed is only the starting point for a sustainable standardization process support. As soon as further organizational processes are elaborated, associated adequate tool support is needed.

The management and further harmonization of use cases can be supported by additional functionality, as for instance grouping of related use cases, selections/sorting of use cases according to specified criteria, search functionality, examining different aspects of use cases and also coverage analyses for defined criteria. Moreover, checks for defined conventions guiding use case development should be implemented to assure quality at creation time.

Concerning the publication and export of results, an attached tool that provides simplified access to the files that may be exported is desirable in order to improve the later exploitation of use cases for a larger public. After the life-cycle of a use case is determined, concepts for round-trip engineering may become more relevant which will for instance require an import functionality.

As this modified version of the original “Chronos Web Modeller” has only been used by a small number of people, there is little information available on the performance and scalability of the system. Further guided evaluation is required to enhance e.g. usability and identify further functionality as well as user requirements. Additionally, different user rights to enable, for instance read only access on specific workspaces or to hide group workspaces which are not relevant to the user, were not required, but it might be necessary in future when more user groups are active. In addition, a more sophisticated workflow support to approve and assign use cases to users responsible for quality assurance is absolutely essential as soon as a larger number of users become involved in use case development.

## 11 Outlook and identified issues

### Concept of use cases

The concept of use cases as a supportive measure for standardization is not limited to the Smart Grid area. The experience collected within the Smart Grid can be reused for a similar process in other domains. It is expected that especially innovative and complex systems might use the advantages of the use case approach for standardization needs (in combination with the overall process defined in the SG-CG/M490/A [21]). Although the template is developed for Smart Grid, the idea of use cases and the process behind it can be adopted to other areas with slight changes.

As described it is necessary, to define or modify standardization processes in detail after these first experiences (refer to chapter 6.6 for first suggestions).

### Identified issues / recommendations:

- To standardization itself
  - o Adopt the use case approach for Smart Grids to more generic standardization together with relevant processes (e.g. related to the current IEC activities and existing IEC procedures, refer to chapter 6.9.3)
  - o Further development of the Use Case Management Repository (UCMR) and its use in standardization
  - o The suggested generic use cases (GUC) are seen as a starting point. New use cases will be developed, but it is recommended that they should be related to the existing GUCs and the existing actor list as far as possible in order to keep the set of GUCs consistent.
  - o Define sufficient level of description for the tasks within standardization

Within this document some first suggestions are made to provide some generic use cases and architectures in order to simplify solutions with respect to standardization.

As shown the use case approach can be performed on different levels of detail. Certainly within a concrete Smart Grid project software engineering has to drill much deeper than it might be necessary for standardization. Nevertheless, a detailed use case includes UML diagrams like activity diagrams and sequence diagrams. At this level of detail, the message payloads exchanged between actors must be precisely defined, using information data models standardized by IEC. But it should be kept in mind that the details of the use cases have to reflect the aim of the use case approach in the SG-CG: it should help standardization.

- o The use case approach is the starting point for having a model driven integration approach for semantic information models standardized at the IEC level, which are recognized as key standards by various studies and roadmaps worldwide.
- To the European Commission (EC)
  - o It is recommended to mandate the use of the developed approach together with the use case template. The UCMR could also be used by publicly funded R&D projects as a means of knowledge management and knowledge transfer towards the relevant community standardization organizations and the legislator (in the case that the use cases are relevant for changes to the legislative framework).
  - o Any R&D project funded by the EC should take into account “Smart Grid Good Working Practices (SGGWP)”. Among those SGGWP, use case definition is essential. A way to define the main objectives of R&D projects should be through a use case work package. Sharing use cases among R&D projects, and having a use case repository would definitely help “not to reinvent the wheel” in different R&D projects.
- On-going discussion
  - o Cooperative approach of legislative and standards developments

Standardized use cases, architectures and standards for the Smart Grid within Europe should go hand in hand with the respective legal framework as it influences the use cases. Partly the legal and regulatory framework might be needed as a basis also for detailed standardized solutions (e.g. regarding a harmonized market design), partly the legislative activities and especially different national legislative frameworks are hindering innovative developments and their timely standardized solutions. Respecting the primacy of political and regulatory decisions, it should be noted that parallel activities without coordination endanger the success of both sides.

The common work of the SG-CG together with the Commission working on the mandate M/490 can be seen as a positive example in this respect. Especially the market area use



cases are highly dependent upon the market design which is mainly based on legal and regulatory frameworks which are currently under discussion. A common approach (e.g. a common smart market expert committee describing relevant use cases which can be used in standardization) is suggested.

Further steps for use case management within the work of the iteration of mandate M/490

**Table 4 – Outlook to the work program during iteration of the mandate M/490**

No.	Next steps / tasks for mandate iteration
<b>A</b>	Use Case Management
A.1	<ul style="list-style-type: none"> <li>- Ongoing: Transfer of the use cases approach (together with an agreed overall process) and the suggested generic use cases towards Technical Committees and relevant stakeholders               <ul style="list-style-type: none"> <li>o Involve TCs</li> <li>o Make new workshops / webinar</li> <li>o Discuss setting up new working groups for topics such as flexibility (e.g. detailing of the GUCs) or use cases related to the market / grid area (including experts from standardization, regulation (e.g. EG3) and grid codes)</li> </ul> </li> </ul> <p>Expected results:</p> <ul style="list-style-type: none"> <li>- Handing over concepts to relevant technical committees for further evaluation</li> <li>- Establishing the proposed processes step by step</li> </ul>
A.2	<p>Ongoing: Continuous work on generic use cases in the UCMR, especially for the flexibility concept</p> <ul style="list-style-type: none"> <li>- details, interrelations, structure</li> <li>- actor list, glossary</li> <li>- mappings</li> <li>- link to other working groups inside the SG-CG</li> </ul>
<b>B</b>	<p>Use Case Management Repository (UCMR)</p> <ul style="list-style-type: none"> <li>- Further develop the UCMR as tool according to a workflow, which has to be defined within the standardization organizations</li> <li>- Integration of new proposed function (e.g. inclusion of mappings and relations)</li> </ul>
<b>C</b>	<p>Ongoing: Processes relevant for the use case approach to hand over the suggested processes to standardization organizations</p> <p>Further alignment with the overall framework and the other developed methodologies in the SG-CG</p>
<b>D</b>	<p>Alignment of methodologies</p> <p>Parallel developed methodologies in the working groups to be further aligned.</p>

## Annex A

### Actors List

Describing all use cases in a consistent manner actors should be standardized as far as possible. For this reason an actor list has been suggested together with the modified template. The actor list is based on existing sources.

This actor list has 3 main sources :

- IEC 61968 Interface Reference Model (which is described in 61968-1 International Standard). This IRM is commonly used in the development of System interfaces for Distribution Management [6]
- ENTSO-E Role Model. Based on ETSO, EFET, EbiX role model. This role model is managed by ENTSO-E. A UML version of this role model can be found. European market leverages this role model [19]
- SMCG : Smart Meter Coordination Group associated to M441 mandate, [8]

The actors are also implemented in the UCMR.

<b>Name</b>	<b>Actor Type</b>	<b>Actor Description</b>	<b>Source</b>
Account Management (ACT)	Application	Business function or service that manages supplier and customer business accounts.	61968-IRM
Accounting Point responsible	Role	Responsible for the maintenance and mapping between the logical registers and the accounting points in compliance with local market rules	ENTSO-E role model
Actor A	External Actor	External actor (Smart Grid Market Role) interacting with the system functions and components in the home or home automation network through the energy management communication channel. Examples of such market roles are the Energy Provider, the Energy Services Provider, the aggregator, etc.	GUC
Actor B	External Actor	External actor (Smart Grid Market Role) interacting with the system functions and components in the home or home automation network through the metering communication channel. This actor is responsible for collecting metering data. Examples of such market roles are the DSO, metering company, etc.	GUC
Aggregator	Role	offers services to aggregate energy production from different sources (generators) and acts towards the grid as one entity, including local aggregation of demand (Demand Response management) and supply (generation management). In cases where the aggregator is not a supplier, it maintains a contract with the supplier.	EG3
AMI operator	generic role	General operator of the AMI system	
AMI service engineer [E]	generic role	External actor responsible for the installation, operation, maintenance and de-installation of the system components. It may access, if properly identified and authorized, those components either directly, via local operation and maintenance interfaces, or from a system component from a higher hierarchical level (e.g. meters may be accessed for maintenance purposes via NNAPs or the HES).	SMCG
AMI System	System	Advanced Metering Infrastructure System	SMCG
Ancillary Services providers	Role		EG3
Appliances	System	Object devices	DKE Repository

Name	Actor Type	Actor Description	Source
Area Energy Service Operator	Role	A party offering services regarding the energy management of a specific location or geographical area. These services could be dedicated to the charge management of electric vehicles as well as the energy management of the location, like tertiary buildings (in such a case the charging of EVs could be included in a local optimization). An Area Energy Service Operator could, at the same time, offer EV charging Energy (e-Mobility) Services (user profile and billing could be integrated in its service offer). Additional information: an Area Energy Service Operator could be considered as an Aggregator for specific services, linked to the charge management.	AhG Charging
Asset investment planning (AM-AIP)	Application	Asset investment planning involves strategy definition and prioritisation, maintenance strategy planning, risk management, programme management and decision-making. It drives the condition, configuration, performance, operating costs, and flexibility of the asset base, with the aim of maximising value.	61968-IRM
Asset Management System	Application	Application which optimizes the utilization of assets regarding loading, maintenance and lifetime	SG3
Balance Responsible Party	Role	A party that has a contract proving financial security and identifying balance responsibility with the imbalance settlement responsible of the market balance area entitling the party to operate in the market. This is the only role allowing a party to buy or sell energy on a wholesale level. Additional information: The meaning of the word "balance" in this context signifies that the quantity contracted to provide or to consume must be equal to the quantity really provided or consumed. Such a party is often owned by a number of market players. Equivalent to "Program responsible party" in the Netherlands. Equivalent to "Balance responsible group" in Germany. Equivalent to "market agent" in Spain.	ENTSO-E role model
Balance Supplier	Role	A party that markets the difference between actual metered energy consumption and the energy bought with firm energy contracts by the party connected to the grid. In addition the balance supplier markets any difference with the firm energy contract (of the party connected to the grid) and the metered production. Additional information: There is only one balance supplier for each metering point.	ENTSO-E role model
Battery Service Operator	Role	A party that operates the service for the battery of an electric vehicle that may include the battery rental. The Battery Service Operator will manage the compromise of usage of the battery between an usage for mobility and an usage for electricity or grid management services. A Battery Service Operator could subscribe to different services like electricity charging services to an Area Energy Service Operator or Energy (e-Mobility) Service Operator. The links with these Energy Operators have not been shown on the diagram only for readability reason. Additional information: a Battery Service Operator could be considered as an Aggregator for the usage of the battery.	AhG Charging
Billing Agent	Role	The party responsible for invoicing a concerned party. Note: This role has been introduced into the role model in order to underline the fact that the Imbalance settlement responsible has not the responsibility to invoice. However this role is not specific to the settlement process and may be used in other processes as required.	ENTSO-E role model
Block energy supplier	Role	A party that is selling energy on a firm basis (a fixed volume per market time period)	ENTSO-E role model
Building Management System	System	A system consisting of several decentralized controllers and a centralized management system to monitor and control the heating, ventilation, air conditioning, light and other facilities within a building.	SG3
Building operator	Role	A consumer of electricity which is a private or business building, may also be involved in contract-based Demand/Response.	near to EG3
Business Planning and Reporting (BPR)	Application	These actors perform strategic business modeling, manpower planning, reporting, account management, and both assess and report on risk, performance and business impact.	61968-IRM
Call Taker	Person	actor generally using a trouble call management system	
Capacity Trader	Role	A party that has a contract to participate in the capacity market to acquire capacity through a Transmission Capacity Allocator. Note: The capacity may be acquired on behalf of an Interconnection Trade Responsible or for sale on secondary	ENTSO-E role model

Name	Actor Type	Actor Description	Source
		capacity markets.	
Charge Spot Area Owner	Role	A party that owns the location in which the charge spots are installed.	AhG Charging
Charge Spot Operator, CSO		Operates charging stations. Receives charge plans and is responsible for the execution of a charge plan. Other responsibilities: Authenticate or relay to CSP for authentication, negotiation of charging capabilities and finally executing charging service request within boundaries (grid capacity, RE/E-availability).Energy metering	GUC
Charging Spot, CS		The connector from station to EV's	GUC
Closed-Loop Controller	Application	Control the grid, when RTSS detects contingency or anomalies that should be immediately be resolved.	GUC
Construction (MC-CON)	Application	Examples of construction work include service installations, line extensions, and system betterment projects.	61968-IRM
Construction supervision (NE-CSP)	Application	Monitoring and management of construction work to minimize negative variances from planned costs, performance, and schedule.	61968-IRM
Consumer	Role	End user of electricity, gas, water or heat. NOTE: As the consumer can also generate energy using a Distributed Energy Resource, he is sometimes called the "Prosumer".	ENTSO-E role model updated by SMCG
Consumer	Role	A party that consumes electricity. Additional information: This is a type of Party Connected to the Grid	ENTSO-E role model
Consumption Responsible Party	Role	A party who can be brought to rights, legally and financially, for any imbalance between energy bought and consumed for all associated metering points. Additional information: This is a type of Balance Responsible Party	ENTSO-E role model
Control Area Operator	Role	Responsible for : 1. The coordination of exchange programs between its related market balance areas and for the exchanges between its associated control areas. 2. The load frequency control for its own area. 3. The coordination of the correction of time deviations.	ENTSO-E role model
Control Block Operator	Role	Responsible for : 1. The coordination of exchanges between its associated control blocks and the organisation of the coordination of exchange programs between its related control areas. 2. The load frequency control within its own block and ensuring that its control areas respect their obligations in respect to load frequency control and time deviation. 3. The organisation of the settlement and/or compensation between its control areas.	ENTSO-E role model
Coordination Center Operator	Role	Responsible for : 1. The coordination of exchange programs between its related control blocks and for the exchanges between its associated coordination center zones. 2. Ensuring that its control blocks respect their obligations in respect to load frequency control. 3. Calculating the time deviation in cooperation with the associated coordination centers. 4. Carrying out the settlement and/or compensation between its control blocks and against the other coordination center zones	ENTSO-E role model
Customer Energy Management System	System	Energy management system for energy customers to optimize the utilization of energy according to supply contracts or other economical targets. Is responsible for gathering flexibilities within the customer premises and providing them to an aggregator, and therefore does not directly participate in flexibility markets	SG3

Name	Actor Type	Actor Description	Source
Customer Energy Manager (CEM)		The CEM is a logical function optimizing energy consumption and or production based on signals received from the grid, consumer's settings and contracts, and devices minimum performance standards. The Customer Energy Manager collects messages sent to and received from connected devices; especially the in-home/building sector has to be mentioned. It can handle general or dedicated load and generation management commands and then forwards these to the connected devices. It provides vice versa information towards the "grid / market". Note that multiple loads/generation resources can be combined in the CEM to be mutually controlled. When the CEM is integrated with communication functionalities it is called a Customer Energy Management System or CEMS.	GUC
Customer Information System	System	System or application which maintains all needed information for energy customers. Typically associated with call center software to provide customer services like hot-line etc.	SG3
Customer Portal	Application	Web-server application which allows utility customers to register and login to retrieve information about their tariffs, consumption and other information.	SG3
Customer service (CS-CSR)	Application	This function set covers the different aspects related to customer interfaces required for operation and commercial purposes.	61968-IRM
Customer Support (CS)	System	Customer Support actors help customers to purchase, provision, schedule installation, troubleshoot power system services, and relay/record customer trouble reports.	61968-IRM
Data Aggregator	System	Devices, which are intermediate machines in a communication network, can aggregate the same timing data from field sensing devices.	GUC
Demand Response Management System	System	a system or an application which maintains the control of many load devices to curtail their energy consumption in response to energy shortages or high energy prices.	SG3
DER		Generic Distributed Energy Resource - "DER devices are generation and energy storage systems that are connected to a power distribution system"	GUC
DER Management System	System	which provides applications to monitor and control a set of DER	
Design (MC-DGN)	Application	A design is created by an engineer or work planner. Designs can be made up of individual line items or by a set of "compatible units" or CUs. Line items and compatible units are associated with a Design Location which is associated with a design location.	61968-IRM
Dispatcher	Person	actor in charge of dispatching Electricity (usually at the transmission level)	
Display (C)	User generic role	External actor interacting directly with the simple external consumer display.	SMCG
Distribution Management System	System	a system which provides applications to monitor and control a distribution grid from a centralized location, typically the control center. A DMS typically has interfaces to other systems, like an GIS or an OMS	SG3
Distribution Network Operator, DNO	Role	Organization responsible for managing the electricity, gas, heat and/or water network supplying consumer premises. Also referred to as DSO.	SMCG
Distribution System Operator (DSO)	Role	according to the Article 2.6 of the Directive: "a natural or legal person responsible for operating, ensuring the maintenance of and, if necessary, developing the distribution system in a given area and, where applicable, its interconnections with other systems and for ensuring the long-term ability of the system to meet reasonable demands for the distribution of electricity". Moreover, the DSO is responsible for regional grid access and grid stability, integration of renewables at the distribution level and regional load balancing.	EG3
DMS Operator	Person	Operator of the Distribution Management System	
El. Vehicle (EV/PHV)	System	An vehicle with an electric drive (as only drive or in combination with a fuel engine) and a battery which can be charged at a charging station.	DKE Repository
Electricity Installer / Contractor	Role	Electrical contractors design, install and maintain intelligent systems for all kinds of industrial, commercial and domestic purposes. Alongside the power and lighting applications, they equally install ICT and telecommunications, public street lighting, high medium and low voltage lines, control and energy management	EG3

Name	Actor Type	Actor Description	Source
		systems, access, fire and security control equipment, lightning protection systems, advertising and identification signs, emergency power generating systems and renewable energy systems.	
Energy (e-Mobility) Service Operator	Role	A party offering specific services for the charge management of electric vehicles. Services included in the EV Charging Energy (e-Mobility) Service. This role is at the interface of the mobility world, which includes the vehicle (including all associated domains with the electric world), and the energy supply (including all the associated domains). Such type of operator will ease the interface with customers, allowing a good optimization of the charge management to the user needs. An Energy (e-Mobility) Service Operator could offer, at the same time, charge reservation either on its own or through subscription to the Area Energy Service Operator. Additional information: an Energy (e-Mobility) Service Operator could be considered as an Aggregator for specific services linked to the charge management. One benefit of a Energy (e-Mobility) Service Operator offering EV Charging Energy (e-Mobility) Services is to offer, from customer point of view, only one interface for the service, regardless the location it will be provided.	AhG Charging
Energy market	B2B	The Energy B2B market is responsible for supplying electricity (and optionally e-pricing)	
Energy Management Gateway	System	An access point (functional entity) sending and receiving smart grid related information and commands between actor A and the CEM, letting the CEM decide how to process the events. The communication is often achieved through an internet connection of through a wireless connection.	GUC
Energy Management LAN	System	Virtual field bus in the smart home, mainly used for energy management functions	DKE Repository
Energy Management System	System	System which provides applications to monitor and control a transmission grid and the output of the connected power plants from a centralized location, typically the control center. A DMS typically has interfaces to other EMS	SG3
Energy Manager	Application	This gateway may also provide services including protocol conversion, device management, security and service capabilities	DKE Repository
Energy Market Management System	System	System which provides applications to manage all transactions and workflows necessary to implement an energy market	SG3
Energy Service Provider, ESP	Role	Organisation offering energy services to the consumer.	SMCG
Energy Trading Application	System	Application(s) which are used to trade energy in corresponding markets, supports the dispatch in the decision to buy, sell or to self-produce energy and also provides facilities to exchange the necessary information with the Energy Market Management Systems.	SG3
Enterprise Resource Planning (ERP)	System	Enterprise Resource Planning (ERP) systems integrate internal and external management information across an entire organization, embracing finance/accounting, manufacturing, sales and service, customer relationship management, etc. (source: Wikipedia)	SG3
Field Actuators	system	Primary equipment switches, which are located along the grid lines, realize control actions from the control facility on the Grid. They can be manually operated or remotely operated	GUC
Field crew	Person	actor on the field	
Field Force Management System	System	Applications helping to manage Field Force	SG3
Field recording (MC-FRD)	Application	Field recording is often accomplished through hand held devices which allow field personnel to view and enter information relevant to the work they are performing in the field. For example, line crews and servicemen can access their respective district maps, do searches by pole number, substation, transformer number, switch numbers, and feeder names.	61968-IRM
Field Sensing Devices	System	Devices, which are spread on the Grid lines, continuously report current dynamic status such as voltage, current, frequency and so on.	
Financial (FIN)	Application	Financial actors measure performance across the whole organization, including the evaluation of investments in capital projects, maintenance, or operations. They track risk, benefits, costs and impact on levels of service.	61968-IRM

Name	Actor Type	Actor Description	Source
Fleet Operator	Role	A party that operates fleets of vehicles (mix of internal combustion engine vehicles and electric ones). The fleet operators could manage their activities in various ways: in private area such as airport fleets or in open market, like car sharing or more conventional car rental. A Fleet Operator could subscribe to different services, like parking services, mobility services and electricity charging services to an Area Energy Service Operator or Energy (e-Mobility) Service Operator. Additional information: a Fleet Operator could be considered as an Aggregator for specific mobility needs, could sometimes predict the energy demand for the mobility of its fleet and therefore aggregate it. He is responsible for the economical optimization between charge management and mobility.	AhG Charging
Flexibility Operator (FO)	Role	generic role which links the role customer and its possibility to provide flexibilities to the roles market and grid; generic role that could be taken by many stakeholders, such as a DSO company, an Energy Service Company (ESCO) or an energy supplier	WGSP
Flexible Load		Load that can be modulated	GUC
Generator	Role	Generating electricity, contributing actively to voltage and reactive power control, required to provide the relevant data (information on outages, forecast, actual production) to the energy marketplace (see also the Articles 2.1 and 2.2 of the Directive).	EG3
Geographic Information System	System	Geographic Information System is a system designed to capture, store, manipulate, analyze, manage, and present all types of geographical data. In the simplest terms, GIS is the merging of cartography, statistical analysis, and database technology.	SG3
Geographical inventory (AM-GINV)	Application	Management of geospatial data, typically by utilizing computer graphics technology to enter, store, and update graphic and non-graphic information. Geographic depictions and related non-graphic data elements for each entity are typically stored in some form of a data store. The graphic representations are referenced using a coordinate system that relates to locations on the surface of the earth. Information in the data store can be queried and displayed based upon either the graphic or non-graphic attributes of the entities.	61968-IRM
GIS Operator	Person	Operator of the Geographical Information System	
Grid	System	Bulk power systems including power generation, transmission, and MV distribution.	GUC
Grid Access Provider	Role	A party responsible for providing access to the grid through a local metering point and its use for energy consumption or production to the party connected to the grid.	ENTSO-E role model
Grid communications network providers	Role	Plan, build and maintain the communications systems that enable the data communication required to maintain grid stability, load balancing and fault protection systems by a TSO or DSO. This function is mostly executed by the TSO or the DSO, or may be performed by an independent actor but the overall responsibility and ownership of information remains with TSO and DSO. 4 Grid communications network provider ensures compliance with the agreed service levels (Service Level Agreements including quality of service, data security and privacy) and compliance with any national and/or international regulations as necessary;	EG3
Grid Operator	Role	A party that operates one or more grids.	ENTSO-E role model
Head End System (HES)	System	Central Data System collecting data via the AMI of various meters in its service area. It communicates via a WAN directly to the meters and/or to the NNAP of LNAP.	SMCG
HES operator (A)	generic role	External actor interacting with the system functions and components via the HES Head End System (Metering)	SMCG
Home automation end device	System	Device providing additional functionalities enabling consumers to interact with their own environment.	SMCG
Home Automation Operator (D)	generic role	External actor interacting directly with the home automation end device.	SMCG
Home customer	Role	A residential consumer of electricity (including also agriculture users) may also be involved in contract-based Demand/Response.	EG3
Human Resources (HR)	Application	Human Resources (HR) actors manage personnel information and activities including safety, training, benefits, performance, review, compensation, recruiting, scheduling, training/employee job-ratings and expenses. HR also determines overtime scheduling and job qualifications for specific tasks.	61968-IRM
Imbalance Settlement	Role	A party that is responsible for settlement of the difference between the contracted quantities and the realised quantities of energy products for the balance responsible parties in a market balance area.	ENTSO-E role model

Name	Actor Type	Actor Description	Source
Responsible			
Industrial consumer	Role	A large consumer of electricity in an industrial / manufacturing industry. May be involved in contract based Demand/Response.	EG3
Interconnection Trade Responsible	Role	Is a Balance Responsible Party or depends on one. He is recognised by the Nomination Validator for the nomination of already allocated capacity. Additional information: This is a type of Balance Responsible Party	ENTSO-E role model
LNAP	System	The Local Network Access Point is a functional entity that provides access to one or more metering end devices, displays and home automation end devices connected to the local network (LN). It may allow data exchange between different functional entities connected to the same LN.	SMCG
Maintenance and Construction (MC)	System	Maintenance and Construction actors coordinate equipment inspection, cleaning and adjustment , organize construction and design, dispatch and schedule maintenance and construction work, capture records gathered by field personnel and permit them to view necessary information to perform their tasks.	61968-IRM
Maintenance and inspection (MC-MAI)	Application	Work involving inspection, cleaning, adjustment, or other service of equipment to enable it to perform better or to extend its service life. Examples of maintenance work are routine oil changes and painting. Examples of inspection work are pole inspections, vault inspections, and substation inspections.	61968-IRM
Market Information Aggregator	Role	Market Information Aggregator, A party that provides market related information that has been compiled from the figures supplied by different actors in the market. This information may also be published or distributed for general use. Note: The Market Information Aggregator may receive information from any market participant that is relevant for publication or distribution.	ENTSO-E role model
Market Operator	Role	The unique power exchange of trades for the actual delivery of energy that receives the bids from the Balance Responsible Parties that have a contract to bid. The market operator determines the market energy price for the market balance area after applying technical constraints from the system operator. It may also establish the price for the reconciliation within a metering grid area.	ENTSO-E role model
Meter Data Collector , MDC	Role	A party responsible for meter reading and quality control of the reading.	ENTSO-E role model
Meter Data Management System, MDMS	System	System for validating, storing, processing and analyzing large quantities of meter data.	ENTSO-E role model
Meter Operator, MO	Role	A party responsible for installing, maintaining, testing, certifying and decommissioning physical meters	ENTSO-E role model
Meter User (B)	generic role	External actor interacting directly with the smart meter (Metering End Device).	SMCG
Metered Data Aggregator , MDA	Role	A party responsible for the establishment and qualification of metered data from the Metered data responsible. This data is aggregated according to a defined set of market rules.	ENTSO-E role model
Mobility Service Operator	Role	A party offering standard mobility services for all type of vehicles (internal combustion engine vehicles as well as plug-in electric or full electric vehicles). "Mobility services" covers maintenance and repair contract, navigation or guidance services, help desk services, driving assistance and any other type of services, linked to any vehicle data management exchanged between the vehicle and a communication platform with data aggregation or mining or extraction operation according data privacy regulations. A Mobility Service Operator could subscribe EV Charging Energy (e-Mobility) Services provided by an Energy (e-Mobility) Service Operator exactly in the same manner as it could subscribe other Area Energy Services managed by an Area Energy Service Operator. Additional information: a Mobility Service Operator could be considered as an Aggregator for conventional mobility services.	AhG Charging
Modeler	Person	Person in charge of modeling the network	



Name	Actor Type	Actor Description	Source
MOL Responsible	Role	Responsible for the management of the available tenders for all Acquiring System Operators to establish the order of the reserve capacity that can be activated.	ENTSO-E role model
Network calculations (NE-NCLC)	Application	Used to develop a long-term (generally one year and beyond) plan for the reliability (adequacy) of the interconnected electric transmission and distribution networks.	61968-IRM
Network Extension Planning (NE)	System	Network Extension planning actors develop long term plans for power system reliability, monitor the cost, performance and schedule of construction, and define projects to extend the network such as new lines, feeders or switchgear.	61968-IRM
Network operation monitoring (NO-NMON)	Application	Part of Network Operation Provides the means for supervising main substation topology (breaker and switch state) and control equipment status. It also provides the utilities for handling network connectivity and loading conditions. It also makes it possible to locate customer telephone complaints and supervise the location of field crews.	61968-IRM
Network operation simulation (OP-SIM)	Application	This set of functions allows facilities to define, prepare and optimise the sequence of operations required for carrying out maintenance work on the system (release/clearance orders) and operational planning.	61968-IRM
Network Operations (NO)	System	The Network Operation domain is a sub-domain within Operation providing the monitoring, control, and maintenance of the utilities network. Key applications include monitoring and control remote field equipment (e.g.: Phase Measurement Units (PMU), capacitor banks, sectionalizers )	61968-IRM
Network Operations Analysis (NO-OFA)	Application	Operation Feedback Analysis actors compare records taken from real-time operation related with information on network incidents, connectivity and loading to optimize operations and schedule periodic maintenance.	61968-IRM
Network Operations Calculations (NO-CLC)	Application	Real-time Network Calculations actors provide system operators with the ability to assess the reliability and security of the power system.	61968-IRM
Network Operations Control (NO-CTL)	Application	Centralized automated and manual control operations of the system to manage the flow of power and optimize reliability of the system. Network control is coordinated by actors in this domain, they may only supervise wide area, substation, and local automatic or manual control. An example would be the use of phase angle regulators within a substation to control power flow between two adjacent power systems	61968-IRM
Network Operations Fault Analysis (NO-FLT)	Application	Fault Management actors enhance the speed at which faults are located, identified, and sectionalized so service can be restored. They provide information for customers, coordinate with workforce dispatch and compile information for statistics.	61968-IRM
Network Operations Reporting and Statistics (NO-OST)	Application	Operational Statistics and Reporting actors archive on-line data and to perform feedback analysis about system efficiency and reliability.	61968-IRM
NNAP	System	The Neighbourhood Network Access Point is a functional entity that provides access to one or more LNAP's, metering end devices, displays and home automation end devices connected to the neighbourhood network (NN). It may allow data exchange between different functional entities connected to the same NN.	SMCG
Nomination Validator	Role	Has the responsibility of ensuring that all capacity nominated is within the allowed limits and confirming all valid nominations to all involved parties. He informs the Interconnection Trade Responsible of the maximum nominated capacity allowed. Depending on market rules for a given interconnection the corresponding System Operators may appoint one Nomination Validator.	ENTSO-E role model
Object device	System	Combination of load and generation object devices	DKE Repository
Operational Planning (OP)	System	Operational Planning and Optimization actors perform simulation of network operations, schedule switching actions, dispatch repair crews, inform affected customers, and schedule the importing of power. They keep the cost of imported power low through peak generation, switching, load shedding or demand response.	61968-IRM

Name	Actor Type	Actor Description	Source
Outage Management System	System	Outage Management System; key application or system for distribution network operations, supports the control room operator during his jobs to plan and coordinate grid maintenance requiring de-energizing of network parts or to coordinate the remedial ac	SG3
Parking Service Operator	Role	A party that offers parking services. A Parking Service Operator could subscribe to electricity charging services to an Area Energy Service Operator or Energy (e-Mobility) Service Operator. He could offer the service, in a complete different manner, including the charging service in the fees of the parking, because the current cost of one hour of parking is higher than the cost of electrical energy delivered by a slow charge service. The links with these Energy Operators have not been shown on the diagram only for readability reason. Additional information: a Parking Service Operator could be considered as an Aggregator.	AhG Charging
Party Connected to the Grid	Role	A party that contracts for the right to consume or produce electricity at a metering point.	ENTSO-E role model
Point of sale (CS-POS)	Application	A point of sale system is used for the management of prepayment meters, where a customer either purchases a token or makes a prepayment for service.	61968-IRM
Power equipment		Equipment which directly operates on the Power System and controlled by SCS, including e.g.: On Load tap changers (OLTC), Switched Capacitor banks , FACTS devices, Voltage Regulator Controllers	GUC
Power import scheduling and optimisation (OP-IMP)	Application	Power import scheduling and optimisation aims to minimise the cost of imported power by keeping the average imported power close to the contracted value, making use of peak plants, load switching or load shedding.	61968-IRM
Power Plant System	System	Applications managing a Power Plant	SG3
Premises (PRM)	Application	Information regarding the location of a service. This set of functions includes: Address management; Right of ways, easements, grants; and Real estate management.	61968-IRM
Process Automation System	System	Automation system to monitor and control industrial production plants.	SG3
Producer	Role	A party that produces electricity Additional information: This is a type of Party Connected to the Grid	ENTSO-E role model
Production Responsible Party	Role	A party who can be brought to rights, legally and financially, for any imbalance between energy sold and produced for all associated metering points. Additional information: This is a type of Balance Responsible Party.	ENTSO-E role model
Project definition (NE-PRJ)	Application	Planned work activities to enhance or extend the network and/or other assets. Example include line extension for new housing development, a new substation, switchgear change at a substation. Capital development projects (i.e., not billed to a customer) are usually justified with an business case.	61968-IRM
Real-time State Estimator (RTSS)	Application	Estimates current spatial-temporal state of grid in real-time. If a contingency in the grid is expected, it triggers a close-loop control or notify systems operators of the contingency via GUIs	GUC
Reconciliation Accountable	Role	A party that is financially accountable for the reconciled volume of energy products for a profiled Local metering point.	ENTSO-E role model
Reconciliation Responsible	Role	A party that is responsible for reconciling, within a Metering grid area, the volumes used in the imbalance settlement process for profiled metering points and the actual metered quantities.	ENTSO-E role model
Records and asset management (AM)	System	The Records and Asset Management actors track and report on the substation and network equipment inventory, provide geospatial data and geographic displays, maintain records on non-electrical assets, and perform asset investment planning.	61968-IRM
Renewable Generation	system	Compute forecast for renewable generation in controlled area based on weather forecast	GUC

Name	Actor Type	Actor Description	Source
Forecaster			
Reserve Allocator	Role	Informs the market of reserve requirements, receives tenders against the requirements and in compliance with the prequalification criteria, determines what tenders meet requirements and assigns tenders.	ENTSO-E role model
Resource Provider	Role	A role that manages a resource object and provides the schedules for it	ENTSO-E role model
Retail Energy Market System	System	Applications related to the Retail Market	SG3
Retailer	Role	Entity selling electrical energy to consumers - could also be a grid user who has a grid connection and access contract with the TSO or DSO. In addition, multiple combinations of different grid user groups (e.g. those grid users that do both consume and produce electricity) exist. In the remainder of this document, the terms customer/consumer and grid user are used interchangeably where appropriate.	EG3
SCADA system	Application	Supervisory Control And Data Acquisition system provides the basic functionality for implementing EMS or DMS, especially provides the communication with the substations to monitor and control the grid.	DKE Repository
Scheduling Coordinator	Role	A party that is responsible for the schedule information and its exchange on behalf of a balance responsible party. For example in the Polish market a Scheduling Coordinator is responsible for information interchange for scheduling and settlement.	ENTSO-E role model
Simple external consumer display	System	Display providing accurate information on consumption, tariffs and so on in order to increase consumer awareness.	SMCG
Simple external consumer display		Dedicated display screen in connection with the smart meter/SGCP available to the customer to check power consumption, planned load reductions and load reductions historical. Other not dedicated means also exist to deliver consumption information to the customer, such as the personal computer, the mobile phone or the TV set.	GUC
Smart appliance (white goods)		An example of a smart device is a smart white goods appliance which is an appliance that has the capability to act in response to a signal from the grid and thereby optimize its behaviour towards the energy supply network. The signal can be received from a utility or a third party energy service provider directly or via a home energy management system. The signal can be information like the cost of energy or the amount of available renewable energy, or it can be a Demand Respond signal (delay load signal or other related information) that the appliance must receive, interpret and react upon based on pre-set or active consumer input. The smart appliance is not guaranteed to respond, but will do so based on its status and user settings in order to ensure the expected performance.  The consumer has the ultimate control of the appliance and can override any specific mode (e.g. override a delay to allow immediate operation, limit delays to no more than a certain number of hours, or maintain a set room temperature). Any appliance operation settings or modes shall be easy for an average, non-technical consumer to activate or implement.	GUC
smart device		A smart device may be an appliance, generator or storage device (Local storage devices include direct and functional electricity storages such as electrochemical batteries, heat pumps and micro CHP such as fuel cells with heat buffers, air conditioning and cooling devices with thermal inertia, etc...). The smart device can receive data directly from the grid, through an interface with the CEM and can react to commands and signals from the grid in an intelligent way.  Since the smart device is outside the scope of the SGCG, it must be seen as an external actor	GUC
Smart Meter (SM)	Meter System	The metering end device is a combination of the following meter-related functions from the Smart Metering reference architecture: <ul style="list-style-type: none"> <li>• Metrology functions including the conventional meter display (register or index) that are under legal metrological control. When under metrological control, these functions shall meet the essential requirements of the MID;</li> <li>• One or more additional functions not covered by the MID. These may also make use of the display;</li> <li>• Meter communication functions.</li> </ul>	GUC

Name	Actor Type	Actor Description	Source
Smart Metering gateway (LNAP)		<p>An access point (functional entity) that allows access to one or more metering end devices and, when equipped with an interface, to advanced display / home automation end devices connected to the local network.</p> <p>A LNAP also may allow data exchange between different functional entities connected to the same LN. The LNAP may act simply as a router transferring messages between the metering end device and/or display/home automation devices and the Neighbourhood network of wide area network.</p> <p>It may also provide services including protocol conversion, device management, security and service capabilities. Services may be provided as functions of the LNAP itself or provide proxy services on behalf of limited capability devices connected to the local network</p>	GUC
Stakeholder Planning and Reporting (SPM)	Application	These actors perform track and manage the needs and concerns of various utility stakeholders by monitoring customer input, regulators, service standards, and legal proceedings.	61968-IRM
Substation and network inventory (AM-EINV)	Application	The electrical substation and network assets that a utility owns, or for which has legal responsibility, and will maintain an accurate asset register developed around an asset hierarchy that supports advanced asset management functions.	61968-IRM
Substation Control System (SCS)		(Primary or secondary) Substation Control System implementing the function. Performs state estimation based on real-time measurement data. Derives control actions from analysis of power flow situation.	GUC
Supplier	Role	Entity that offers contracts for supply of energy to a consumer (the supply contract). Within this role he will initiate DSM activities NOTE: In some countries referred to as Retailer	ENTSO-E role model
Supply Chain Logistics (SC)	Application	Business function or service that manages supplier and customer business accounts.	61968-IRM
Switch action scheduling / operation work scheduling (OP-SSC)	Application	Switch action scheduling provides supports for handling all aspects relevant to switch order formulation, drawing up operating guidelines, dispatching repair crews and informing customers affected. It assists in collecting the related data and delivering it in the various forms required.	61968-IRM
System Administrator	Person		
System Operator	Role	A party that is responsible for a stable power system operation (including the organisation of physical balance) through a transmission grid in a geographical area. The SO will also determine and be responsible for cross border capacity and exchanges. If necessary he may reduce allocated capacity to ensure operational stability. Transmission as mentioned above means "the transport of electricity on the extra high or high voltage network with a view to its delivery to final customers or to distributors. Operation of transmission includes as well the tasks of system operation concerning its management of energy flows, reliability of the system and availability of all necessary system services." (definition taken from the UCTE Operation handbook Glossary). Note: additional obligations may be imposed through local market rules.	ENTSO-E role model
System Operator	Person	Operator who monitors dynamic behavior of the Grid via GUIs and take actions to either prevent contingencies or improve system efficiency.	GUC
Timer	System	An initiator that triggers of time based/scheduled use cases	SMCG
Trade Responsible Party	Role	A party who can be brought to rights, legally and financially, for any imbalance between energy bought and consumed for all associated metering points. Note: A power exchange without any privileged responsibilities acts as a Trade Responsible Party Additional information: This is a type of Balance Responsible Party.	ENTSO-E role model

Name	Actor Type	Actor Description	Source
Transmission Capacity Allocator	Role	Manages the allocation of transmission capacity for an allocated capacity area. For explicit auctions: The Transmission Capacity Allocator manages, on behalf of the System Operators, the allocation of available transmission capacity for an Allocated capacity area. He offers the available transmission capacity to the market, allocates the available transmission capacity to individual Capacity Traders and calculates the billing amount of already allocated capacities to the Capacity Traders.	ENTSO-E role model
Transmission System Operator (TSO)	Role	according to the Article 2.4 of the Electricity Directive 2009/72/EC (Directive): "a natural or legal person responsible for operating, ensuring the maintenance of and, if necessary, developing the transmission system in a given area and, where applicable, its interconnections with other systems, and for ensuring the long-term ability of the system to meet reasonable demands for the transmission of electricity". Moreover, the TSO is responsible for connection of all grid users at the transmission level and connection of the DSOs within the TSO control area.	EG3
Transportation consumer	Role	A consumer of electricity providing transport systems. May be involved in contract based Demand/Response.	EG3
Trouble call management (CS-TCM)	Application	Customer troubles related to blackouts are transmitted and compared with network data in order to provide accurate information on the incident.	61968-IRM
Utility Business Systems (UBS)	System	Usually called back-office systems	
Vehicle Manufacturer	Role	A party that produces the electric vehicles, develops the data information messages, which will be available for the service management.	AhG Charging
Vehicle Owner	Role	A party that owns the electric vehicle.	AhG Charging
Vehicle User	Role	A party that uses the electric vehicle (a physical person as well as a social one).His goal is to be able to use the vehicle, when he needs it or wants to use it. His involvement in the charge management process is essential but, this will hardly depend on the services offered to him.	AhG Charging
Weather Forecast System	System	provides weather forecast used for different utility business processes (scheduling, planning, operational planning, operation ...)	WGSP
Whole Sale Energy Market	System	Applications related to the Energy Wholesale Market	SG3
Wide Area Monitoring System	System	Wide Area Monitoring System; system or application which evaluates incoming information from PMUs to derive information about the dynamic stability of the grid	SG3
Wide-area Monitoring (WAMON)	Application	Provides the means for supervising the overall grid and each equipment status. It triggers real-time data analysis after ensuring trustworthy of raw data from field sensing devices.	GUC
Work scheduling and dispatching (MC-SCHD)	Application	Work scheduling and dispatching makes it possible, for a defined scope of work, to assign the required resources and keep track of work progress.	61968-IRM

## Annex B

### Report about the work of the working group Sustainable Process SG-CG/SP

The SG-CG/SP worked on the following tasks:

**Table 5 – Overview of the work program and the relation to the chapters of the report**

Achievements / Tasks	Reference within this document
<b>Use case management</b>	
Use case template – short, general and detailed Description of the Template	Description of use case template For further reference, see New Work Item Proposal for a Use Case Standard 8/1307/NP in IEC / TC 8 [9]
Use case structure/methodology	Chapter 6.5
Actor list	ANNEX A <i>Actor List</i>
Workshop / webinar about use cases and the use cases template before collection – 26 <sup>th</sup> September 2011	Invitation to stakeholders
Collection of use cases –	Invitation to stakeholders to provide use cases
Use Case Management Repository (UMCR)	Chapter 10 Description of the Use Case Management Repository (UCMR)
Processes for a use cases approach, current and intermediate processes and suggestions for a sustainable implementation in the standardization organizations, started hand over of these results	Chapter 6.6  Refer to 8/1307/NP
<b>Use case analysis and harmonization</b>	
Analysis of use cases and mapping	Chapter 7 Collection of use cases in the Smart Grid Chapter 9.3 Analysis of the SG-CG/SP generic use cases
Overview of all received use cases (> 450 use cases within 6 weeks of collection) together with a first mapping to various criteria (including the high level services of the EG1 report of the European Commission [12])	All use cases descriptions are available in the UCMR. A list of all contributors to the use case collection is available below in this annex
Harmonization of use cases => <ul style="list-style-type: none"> <li>- Definition of generic use cases based on the received use cases</li> <li>- Conceptual descriptions for a flexibility concept and for smart charging (EV) together with open workshops around these concepts, first contact to TC's</li> </ul>	Chapter 8 and 9 UCMR
Recommendations for the further use of the use case approach	Refer to Chapter 11

The Working Group Sustainable Process (SG-CG/SP) being part of the Smart Grid Coordination Group (SG-CG) have **xxx** members and approx 15 active participants contributing to the meetings and work of the SG-CG/SP.

The SG-CG/SP met internally in 2011 six times (20 June, 27&28 July, 7 September, 27 September, 9 November, 14 December) and in 2012 six times (21&22 February, 16&17 April, 5&6 June, 17&28 July, 24&25 September, 30&31 October).

Approx. 20 conference calls have been used for coordination and exchange.

Beneath these internal meetings the SG-CG/SP carried out following public stakeholder activities:

- 26 September 2011: Workshop to inform about the use cases methodology before starting the use case collection
- 26 September until Middle of November 2011: use case collection
- 21 May 2012: Workshop around the flexibility concept
- 31 May 2012: Workshop around the smart charging concept

Furthermore the WG participated in the SG-CG plenary, steering group as well as in the meetings with EC reference group, the alignment workshop, the international plenary.

Many stakeholders and committees were interested in the work of the SG-CG/SP. The SG-CG/SP members were invited to present the preliminary results at various occasions like conferences, standardization committees or R&D projects.

For example the SG-CG/SP worked together with IEC/TC 8 AHG 4 and supported the work on a new work item proposal [9] for a use case template. The UCMR was presented to and supported by the international community.

The work was done in the following steps:

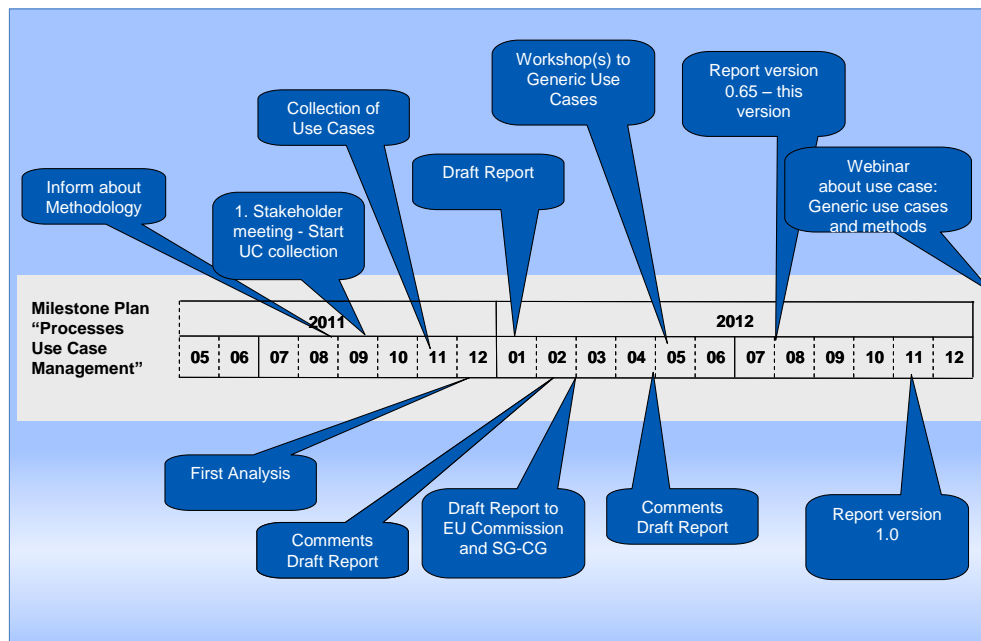

- Methodology
- SG-CG/SP worked out a modified template and organized the use case collection
- Use case collection

The SG-CG/SP asked a broad variety of Smart Grid stakeholder to provide their most important Smart Grid use cases using a modified template which was based on [1].

Within six weeks over 450 use cases had been provided from various stakeholders.

- Analysis of the provided use cases

SG-CG/SP analyzed the use case provided.

This part of the work led to the development of the generic use case and the conceptual descriptions.

- Use Case Management Repository

SG-CG/SP supported the development of the UCMR. All use cases are transferred to the UCMR.

- Reports

Three previous versions of the report had been provided and received comments had been taken into account. Furthermore the generic use case and conceptual descriptions were discussed in two public workshops.

## B.1 Description of use case template<sup>33</sup> and selection list

These documents had been developed as intermediate working documents for the use cases collection and the UCMR as well as the GUC. The documents had been introduced into the standardization (IEC/TC 8).

## B.2 Contributors to the use case collection

The following stakeholders had contributed to the use case collection. They had a great influence on this report and their input was highly welcomed. As the current work is relying mostly on the use cases provided to the group, the SG-CG/SP likes to thank all contributors for their use cases which were provided within a very short time frame.

Name	provided use cases for	Company
Andersen, Claus Amstrup	ENERGINET.DK,	EURISCO
Becker, Achim	MeRegio E-Energy	IBM
Cerretti, Alberto	CEI, EURELECTRIC	ENEL
Colton, Larry	ESNA	Echelon
Dolan, Michael	EERA	Institute for Energy and Environment
Di Carlo, Stella	ADDRESS	ENEL
Ectors, Dominic	EERA	Vito
Gould, Lee	CENELEC TC 205	Kinberry Limited
Guise, Laurent	TC 57 / TC 38	Schneider Electric
Aki Hämäläinen / Helen Sähköverkko	FIN NC	
Herion, Celine	CECED	CECED
Kaestle, Gunnar	DKE	TU Clausthal, Institut für Elektrische Energietechnik
Kiessling, Andreas	E-Energy/MOMA	MVV
Kormanicki, Przemyslaw	Web2Energy, Harz.EE-mobility	Fraunhofer Institute for Factory Operation and
Lambert, Eric	DER-ri, EDF	EDF
Leipold, Rio	DKE/DIN	Ubitercity

<sup>33</sup> Remark: Work on a new template has started in IEC/TC 8 WG 5 based on 8/1307/NP. Template of the use case collection was introduced.



Name	provided use cases for	Company
Lennart Verheijen	Enexis	Enexis
Malina, Alfred	DKE	IBM
Martigne, Patricia	ETSI M2M	Orange
Mennella, Jean-Pierre	SG-CG/SGIS	Alstom
Menz, Tobias	DKE	BTC
Monti, Antonello; Schäfer, Bettina	RWTH Aachen	RWTH Aachen
Niemand, Thomas	RWE	RWE
Ossel, Mark	ESNA	Echelon
Postma, Andre	E-Iaad, Integral / Power Matcher,	Enexis
Quadflieg, Dieter	FNN	FNN
Selzam, Patrick	DKE	
Soriano Borrull, Raúl	Open Node	ITE Ingeniero de SW
Spillet, David	ENA	Energynetworks
Staubermann, Michael	DKE	Webolution
Stefferd, Kay	NIST and SCE	Enernex
Strabbing, Willem	ESMIG	ESMIG
Strasser, Thomas	DERri, AIT	AIT Austrian Institute of Technology
Tornelli, Carlo	EERA. RSE	Ricerca sul Sistema Energetico - RSE S.p.A.
Tretter, Richard		SWM Stadtwerke München
Verhoosel, Jack	MIRABEL	TNO
Vesa, Juha	FIN NC	SESKO
van der Hulst, Derrick	Easy Street	
von Jagwitz, Alexander	FINSENY	B.A.U.M. Consult GmbH

Thanks also to the members of the SG-CG/SP, who spent their time in reviewing, analyzing and clustering the high number of received use cases as well as working out the suggested Generic Use Cases.

### B.3 Analysis of the collected use cases

Based on the collected use cases and a first analysis, the use cases had been grouped in first clusters. Major trends had been identified by grouping use cases to main fields (intermediate step) which resulted in the further progress into generic use case or clusters of generic use cases. Those use cases belonging to such a main field are (partly) overlapping and quite similar from a general point of view. Examples are the suggested use cases like fault location, isolation and restoration (FLIR), volt var optimization (VVO) etc. Based on these main fields and the use cases behind, the general ideas had been condensed in the description of generic use cases (GUC), clusters and conceptual descriptions (Figure 4). But the generic use cases are mainly based on the provided use cases.

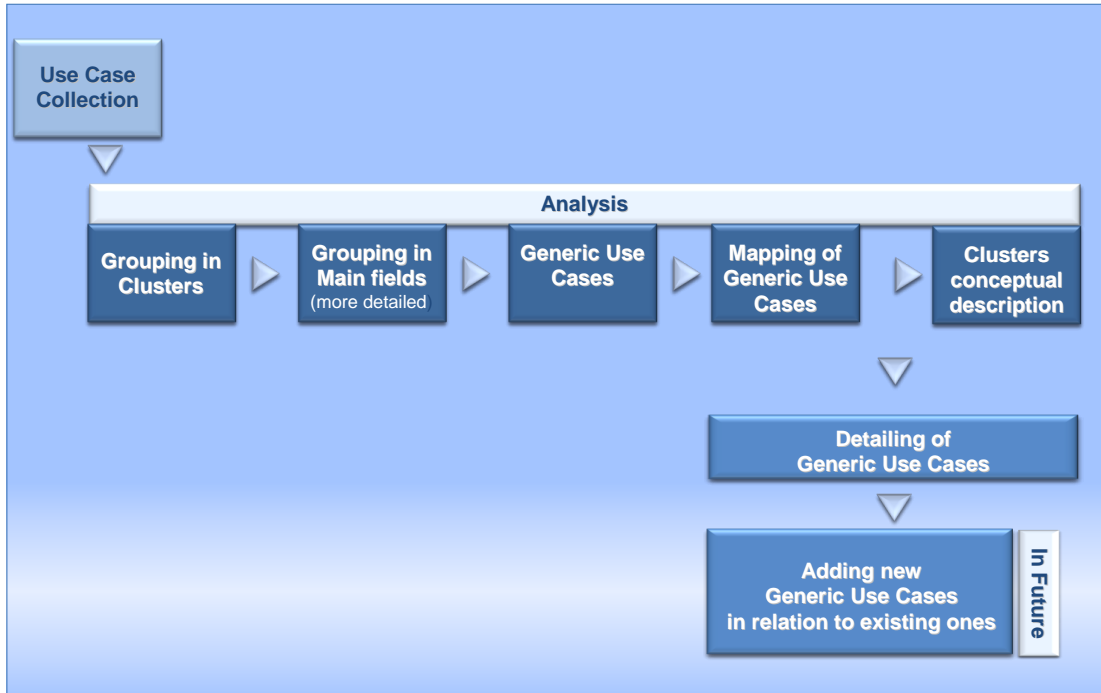

**Figure 28 – Process of analysis and grouping towards generic use cases**

#### Mapping to domains

In a further step the use cases can roughly be related to domains. Whereas the clusters and main fields had been developed together with the grouping and analysis of the collected use cases, the class *domain* is commonly used and related to the main tasks of the energy systems as shown in the next table (refer also the conceptual models of IEC, NIST or SG-CG/M490/C Reference Architecture). In this case the functional domains of IEC / TC 8<sup>34</sup> had been used in a first step with an added domain *security*<sup>35</sup>.

NOTE These functional domains selected at the beginning of the work should not be confused with the domains defined in parallel in the SGAM, which had been proposed by the SG-CG/M490/C RA<sup>36</sup>.

As most of the uses cases are cross-cutting they can be counted for multiple domains which means that the sum of the numbers below is higher than the related use cases:

<sup>34</sup> Reference: IEC TC8/WG4 Use Case Workshop, Draft minutes of the 2nd TC8/WG4 Use Case Workshop held in Los Angeles, California, USA on 9/10 June 2011

<sup>35</sup> Special use cases for information security had been provided by the SG-CG/SGIS within the given template, refer to Annex E. They are not taken into account here, as they are related to the work of SG-CG/SGIS.

<sup>36</sup> Will be harmonized in the next version of this report

**Table 6 – Number of use cases related to Domains as defined in the template originally**

IEC / TC 8 Functional Domain	approx number of provided use cases which can be mapped to this domain
Transmission Grid Management	25
Distribution Grid Management / Microgrid	170
Smart Substation Automation	33
Distributed Energy Resources (DER)	80
Advanced Metering Infrastructure	81
Energy Storage	11
Electric-transportation (ET)	50
Asset Management	4
Bulk Generation	1
Market	69
Security and Privacy	20

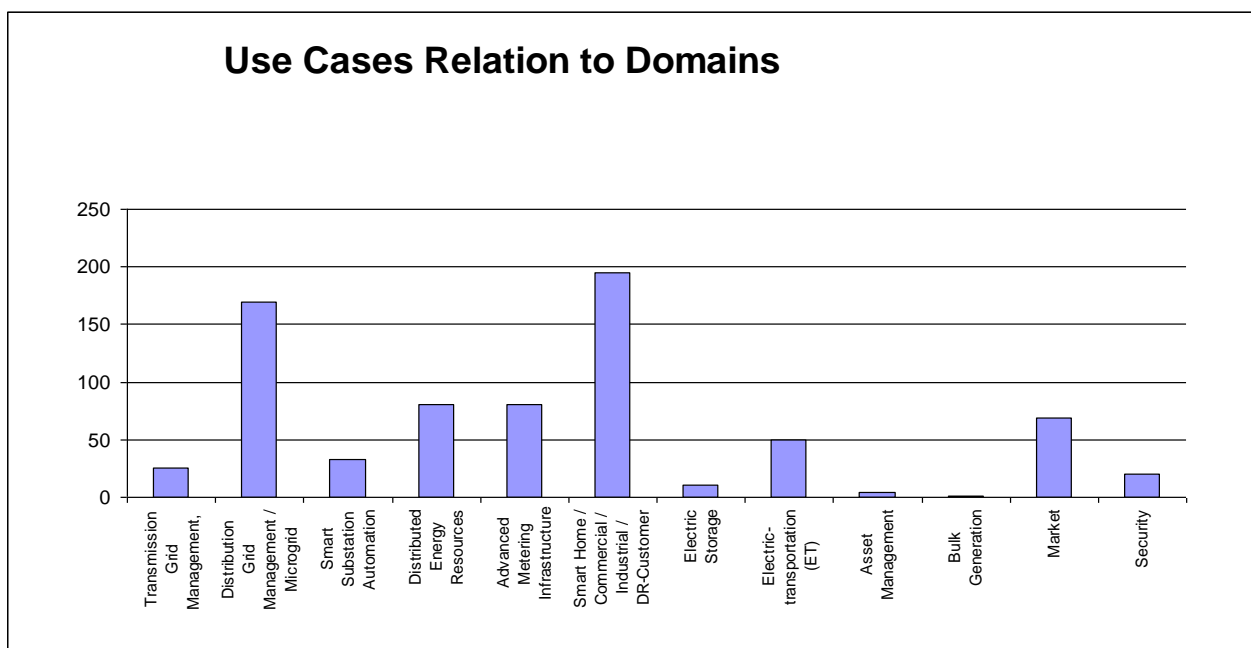

**Figure 29 – Use Cases Relation to Domains**

Mapping to EG1 high level services [12]

The former Task Force *Smart Grids* of the European Commission and its Expert Group (EG1) worked out a list of high level services and high level functionalities which are understood as business requirements of a future Smart Grid which can lead to technical use cases which are important for standardization. So the high level services might be mapped to the business layer of the SGAM.

Use cases had been mapped to these high level services. Further details can be found in the UCMR. The following table provides a mapping of received use cases to these high level services. Therefore this analysis provides a first indication, if there are use cases supporting the EG1 expectations and how many use cases can be related to these business requirements.

**Table 7 – Number of use cases related to the high level services defined in the EG1-Report of the EC**

<b>High Level Services</b>	<b>Number of related use case</b>	<b>in %</b>
A. Enabling the network to integrate users with new requirements	100	18%
B. Enhancing efficiency in day-to-day grid operation	107	19%
C. Ensuring network security, system control and quality of supply	94	16%
D. Enabling better planning of future network investment	38	7%
E. Improving market functioning and customer service	144	25%
F. Enabling and encouraging stronger and more direct involvement of consumers in their energy usage and management	88	15%

## 12 Bibliography

- [27] Bundesnetzagentur (German regulator): “Smart Grid” und “Smart Markets” Eckpunktepapier der Bundesnetzagentur zu den sich ändernden Aspekten des Energieversorgungssystems (“Smart Grid” and “Smart Markets” White paper of Bundesnetzagentur regarding the changing aspects of the energy supply system), available in German <http://www.bundesnetzagentur.de>, Bonn, 2012
- [28] EURELECTRIC: EURELECTRIC Views on Demand-Side Participation, <http://www2.eurelectric.org>, Brussels, 2011
- [29] ADDRESS Project, Active Distribution network with full integration of Demand and distributed energy RESourceS, <http://www.addressfp7.org/>
- [30] ADDRESS, “The ADDRESS Project: Developing Active Demand in Smart Power Systems integrating Renewables”, Régine Belhomme, Ramon Cerero, Giovanni Valtorta and Philippe Eyrolles, IEEE General Meeting, Detroit, USA, July 2011
- [31] R&D Project E-Energy, <http://www.e-energy.de/en/>
- [32] Alistair Cockburn, “Writing Effective Use Cases”, Addison-Wesley, 2001
- [33] MIRABEL - Micro-Request-Based Aggregation, Forecasting and Scheduling of Energy Demand, Supply and Distribution”
- [34] FINSENY Project, Future INternet for Smart ENergy, <http://www.fi-ppp-finseny.eu/deliverables/>