

**EUROPEAN COMMISSION**  
**DIRECTORATE-GENERAL FOR ENERGY**

Directorate E - Euratom Safeguards  
**The Director**

Luxembourg,  
 DG ENER E1 ST/bk Ares(2015)

**Subject: Invitation to tender ENER/E1/2015-37-11 for a supply contract regarding the acquisition of 40000 two piece cup seals, brass and copper**

Dear Sir/Madam,

1. The European Commission is planning to award the public contract referred to above. Please find enclosed the related tender specification listing all the documents that must be produced in order to submit a tender, and the draft contract.
2. If you are interested in this contract, you should submit a tender in one original and two copies in one of the official languages of the European Union. A copy of the offer on a CD/DVD/USB stick has also to be submitted.
3. Tenderers shall submit tenders by letter:
  - a) either by post or by courier not later than 09/10/2015, in which case the evidence of the date of dispatch shall be constituted by the postmark or the date of the deposit slip, to the address indicated below.
  - b) or delivered by hand not later than 16.00 on 09/10/2015 to the address indicated below. In this case, a receipt must be obtained as proof of submission, signed and dated by the official in the Commission's central mail department who took delivery.

The department is open from 08.30 to 17.30 Monday to Thursday, and from 08.30 to 16.30 on Fridays. It is closed on Saturdays, Sundays and Commission holidays.

<p><u>By post:</u></p> <p>CALL FOR TENDERS                  ENER/E1/2015-37-11                  European Commission                  Directorate-Energy                  Direction E - EURATOM Safeguards                  For the attention of Mr Meylemans/                  Mr Stamatopol EUFO 3485                  Complexe Euroforum                  1, rue Henri M. Schnadt                  Zone d'activités Cloche d'Or                  L – 2530 Luxembourg</p>	<p><u>By courier or by hand:</u></p> <p>CALL FOR TENDERS                  ENER/E1/2015-37-11                  European Commission                  Directorate Energy                  Direction E - EURATOM Safeguards                  For the attention of Mr Meylemans/                  Mr Stamatopol EUFO 3485                  Complexe Euroforum                  1, rue Henri M. Schnadt                  Zone d'activités Cloche d'Or                  L – 2530 Luxembourg</p>
--	--

Tenders must be placed inside two sealed envelopes. **The inner envelope, addressed as indicated above, should be marked as follows: "CALL FOR TENDERS – NOT TO BE OPENED BY THE INTERNAL MAIL DEPARTMENT "**. If self-adhesive envelopes are used, they must be sealed with adhesive tape and the sender must sign across this tape.

The inner envelope must also contain two sealed envelopes, one containing the technical tender and the other the financial tender. Each of these envelopes must clearly indicate the content ("Administrative and technical parts" and "Financial offer (part E)").

**For your bid to be found admissible the confidentiality thereof must have been ensured and the deadline for the submission of the bids met.**

4. Tenders must be:
  - signed by a duly authorised representative of the tenderer. The original signature of the single tenderer's or lead partner's authorised representative (preferably in blue ink) on the identification form (Annex 1 of the technical specifications) shall be considered as the signature of the tender, binding the single tenderer or the group of partners to the terms included in the tender;
  - perfectly legible so that there can be no doubt as to words and figures;
5. The period of validity of the tender, during which tenderers may not modify the terms of their tenders in any respect, is six months from the final date for submission.
6. Submission of a tender implies acceptance of all the terms and conditions set out in this invitation to tender, in the tender specification and in the draft contract and, where appropriate, waiver of the tenderer's own general or specific terms and conditions. Submission of a tender is binding on the tenderer to whom the contract is awarded for the duration of the contract.
7. All costs incurred during the preparation and submission of tenders are to be borne by the tenderers and will not be reimbursed.
8. Contacts between the contracting authority and tenderers are prohibited throughout the procedure save in exceptional circumstances and under the following conditions only:
  - Before the final date for submission of tenders:
  - \* At the request of the tenderer, the contracting authority may provide additional information solely for the purpose of clarifying the nature of the contract.

Any requests for additional information must be made in writing only to [Stephane.Tempesta@ec.europa.eu](mailto:Stephane.Tempesta@ec.europa.eu) and [ENER-El-CFT@ec.europa.eu](mailto:ENER-El-CFT@ec.europa.eu). Requests for additional information received less than five working days before the final date for submission of tenders will not be processed.

- \* The Commission may, on its own initiative, inform interested parties of any error, inaccuracy, omission or any other clerical error in the text of the call for tenders.

- \* Any additional information including that referred to above will be posted on [http://ec.europa.eu/dgs/energy/tenders/index\\_en.htm](http://ec.europa.eu/dgs/energy/tenders/index_en.htm)  
The website will be updated regularly and it is the tenderers' responsibility to check for updates and modifications during the tendering period and sent simultaneously to all candidates invited to tender.
  - After the opening of tenders
  - \* If clarification is required or if obvious clerical errors in the tender need to be corrected, the contracting authority may contact the tenderer provided the terms of the tender are not modified as a result.
  - \* The contracting authority may negotiate with tenderers the tenders they have submitted, in order to adapt them to the requirements set out in the contract notice, tender specifications or any additional document and in order to find the tender offering best value for money. During negotiations equal treatment of all tenderers will be ensured.
9. This invitation to tender is in no way binding on the Commission. The Commission's contractual obligation commences only upon signature of the contract with the successful tenderer.
  10. Up to the point of signature, the contracting authority may either abandon the procurement or cancel the award procedure, without the candidates or tenderers being entitled to claim any compensation. This decision must be substantiated and the candidates or tenderers notified.
  11. Once the Commission has opened the tender, the document shall become the property of the Commission and it shall be treated confidentially.
  12. You will be informed of the outcome of this procurement procedure.
  13. If processing your reply to the invitation to tender involves the recording and processing of personal data (such as your name, address and CV), such data will be processed pursuant to Regulation (EC) No 45/2001 on the protection of individuals with regard to the processing of personal data by the Community institutions and bodies and on the free movement of such data. Unless indicated otherwise, your replies to the questions and any personal data requested are required to evaluate your tender in accordance with the specifications of the invitation to tender and will be processed solely for that purpose by the Director of the Shared Resources Directorate. Details concerning the processing of your personal data are available on the privacy statement at: [http://ec.europa.eu/dataprotectionofficer/privacystatement\\_publicprocurement\\_en.pdf](http://ec.europa.eu/dataprotectionofficer/privacystatement_publicprocurement_en.pdf).
  14. Your personal data may be registered in the Early Warning System (EWS) only or both in the EWS and Central Exclusion Database (CED) by the Accounting Officer of the Commission, should you be in one of the situations mentioned in:
    - Commission Decision 2014/792/EU of 13 November 2014 on the Early Warning System to be used by authorising officers of the Commission and by the executive agencies (OJ L 329, 14.11.2014, p.68) (for more information see the Privacy Statement

at  
[http://ec.europa.eu/budget/contracts\\_grants/info\\_contracts/legal\\_entities/legal\\_entities\\_en.cfm](http://ec.europa.eu/budget/contracts_grants/info_contracts/legal_entities/legal_entities_en.cfm)),

or

- Commission Regulation 2008/1302 of 17.12.2008 on the Central Exclusion Database  
(for more information see the Privacy Statement at  
[http://ec.europa.eu/budget/explained/management/protecting/protect\\_en.cfm#BDCE](http://ec.europa.eu/budget/explained/management/protecting/protect_en.cfm#BDCE) )

Yours faithfully,

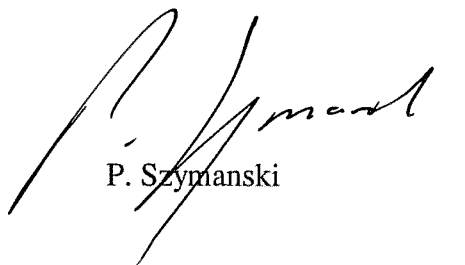

P. Szymanski



**EUROPEAN COMMISSION**  
**DIRECTORATE-GENERAL FOR ENERGY**

Directorate E - Euratom Safeguards  
**E.1 - Quality assurance and technology**

**CALL FOR TENDERS**  
**ENER/E1/2015-37-11**

**Acquisition of 40000 two piece cup seals, brass and copper**  
**TENDER SPECIFICATIONS**

## TABLE OF CONTENTS

1.	INFORMATION ON TENDERING .....	7
1.1.	Participation .....	7
1.2.	Contractual conditions.....	7
1.3.	Joint tenders.....	7
1.4.	Subcontracting.....	7
1.5.	Content of the tender .....	8
1.6.	Identification of the tenderer: legal capacity and status.....	8
2.	EVALUATION AND AWARD .....	9
2.1.	Evaluation steps.....	9
2.2.	Exclusion criteria.....	9
2.3.	Selection criteria.....	9
2.4.	Technical offer .....	10
2.5.	Financial offer .....	10
2.6.	Award of the contract.....	11
3.	TECHNICAL SPECIFICATIONS .....	11
4.	ANNEXES .....	17

# 1. INFORMATION ON TENDERING

## 1.1. Participation

The invitation was sent to 3 candidates but participation in this tender procedure is open on equal terms to all natural and legal persons coming within the scope of the Treaties and to all natural and legal persons in a third country which has a special agreement with the Union in the field of public procurement on the conditions laid down in that agreement. Where the Multilateral Agreement on Government Procurement<sup>1</sup> concluded within the WTO applies, the participation to the call for tenders is also open to nationals of the countries that have ratified this Agreement, on the conditions it lays down.

## 1.2. Contractual conditions

The tenderer should bear in mind the contract provisions which specify the rights and obligations of the contractor, particularly those on payments, performance of the contract, confidentiality, and checks and audits.

## 1.3. Joint tenders

A joint tender is a situation where a tender is submitted by a group of economic operators (consortium). Joint tenders may include subcontractors in addition to the joint tenderers.

In case of joint tender, all economic operators in a joint tender assume joint and several liability towards the Contracting Authority for the performance of the contract as a whole.

These economic operators shall designate one of them to act as leader with full authority to bind the grouping or the consortium and each of its members. It shall be responsible for the receipt and processing of payments for members of the grouping, for managing the service administration and for coordination. The composition and constitution of the grouping or consortium, and the allocation of the scope of tasks amongst the members, shall not be altered without the prior written consent of the Commission.

The tenderers should indicate in their offer whether the partnership takes the form of:

a) a new or existing legal entity which will sign the contract with the Commission in case of award

or

b) a group of partners not constituting a new legal entity, who via a power of attorney, signed by an authorised representative of each partner (except the lead partner), designate one of the partners as lead partner, and mandate him as lead contractor to sign the contract with the Commission in case of award.

## 1.4. Subcontracting

Subcontracting is permitted in the tender but the contractor will retain full liability towards the Contracting Authority for performance of the contract as a whole.

---

<sup>1</sup> See [http://www.wto.org/english/tratop\\_E/gproc\\_e/gp\\_gpa\\_e.htm](http://www.wto.org/english/tratop_E/gproc_e/gp_gpa_e.htm)

Tenderers must give an indication of the part of the services and proportion of the contract that they intend to subcontract.

Tenderers are required to identify subcontractors whose share of the contract is above 20%.

During contract execution, the change of any subcontractor identified in the tender will be subject to prior written approval of the Contracting Authority.

### **1.5. Content of the tender**

The tenders must be presented as follows:

Part A: Identification of the tenderer (see section 1.6)

Part B: Evidence for exclusion criteria (see section 2.2)

Part C: Evidence for selection criteria (see section 2.3)

Part D: Technical offer (see section 2.4)

Part E: Financial offer (see section 2.5)

Part F: Power of attorney (for consortia only)

### **1.6. Identification of the tenderer: legal capacity and status**

- The tenderer's identification form in **Annex 1** shall be filled in and signed by:
  - The tenderer
  - subcontractor(s) whose share of the work represent more than 20% of the contract.
- In order to prove their legal capacity and their status, all tenderers must provide a signed **Legal Entity Form with its supporting evidence**. The form is available on:

[http://ec.europa.eu/budget/contracts\\_grants/info\\_contracts/legal\\_entities/legal\\_entities\\_en.cfm](http://ec.europa.eu/budget/contracts_grants/info_contracts/legal_entities/legal_entities_en.cfm)

Tenderers that are already registered in the Contracting Authority's accounting system (i.e. they have already been direct contractors) must provide the form but are not obliged to provide the supporting evidence.

- If it has not been included with the Legal Entity Form, tenderers must provide the following information
  - For legal persons, a legible copy of the notice of appointment of the **persons authorised to represent the tenderer** in dealings with third parties and in legal proceedings, or a copy of the publication of such appointment if the legislation which applies to the legal entity concerned requires such publication. Any delegation of this authorisation to another representative not indicated in the official appointment must be evidenced.
  - For natural persons, where applicable, a proof of registration on a professional or trade register or any other official document showing the registration number.



- The tenderer must provide a **Financial Identification Form and supporting documents**. The form is available on: [http://ec.europa.eu/budget/contracts\\_grants/info\\_contracts/index\\_en.cfm](http://ec.europa.eu/budget/contracts_grants/info_contracts/index_en.cfm)

## **2. EVALUATION AND AWARD**

### **2.1. Evaluation steps**

The evaluation is based on the information provided in the submitted tender. It takes place in three steps:

- (1) Verification of non-exclusion of tenderers on the basis of the exclusion criteria
- (2) Selection of tenderers on the basis of selection criteria
- (3) Evaluation of tenders on the basis of the award criteria (technical and financial evaluation)

Only tenders meeting the requirements of one step will pass on to the next step.

### **2.2. Exclusion criteria**

All tenderers shall provide a declaration on their honour (see Annex 2), duly signed and dated by an authorised representative, stating that they are not in one of the situations of exclusion listed in the Annex 2.

The declaration on honour is also required for identified subcontractors whose intended share of the contract is above 20%.

### **2.3. Selection criteria**

Tenderers must prove their economic, financial, technical and professional capacity to carry out the work subject to this call for tenders.

The tenderer may rely on the capacities of other entities, regardless of the legal nature of the links which it has with them. It must in that case prove to the Contracting Authority that it will have at its disposal the resources necessary for performance of the contract, for example by producing an undertaking on the part of those entities to place those resources at its disposal.

#### **2.3.1. Economic and financial capacity criteria and evidence**

In order to prove their economic and financial capacity, the tenderer (i.e. in case of joint tender, the combined capacity of all members of the consortium) must comply with the following criteria:

- The annual turnover of the last two financial years above € 50000.

The following evidence should be provided:

- Copy of the profit & loss account for the last two years for which accounts have been closed,

- Failing that, appropriate statements from banks,
- If applicable, evidence of professional risk indemnity insurance.

If, for some exceptional reason which the Contracting Authority considers justified, a tenderer is unable to provide one or other of the above documents, he or she may prove his or her economic and financial capacity by any other document which the Contracting Authority considers appropriate. In any case, the Contracting Authority must at least be notified of the exceptional reason and its justification in the tender. The Commission reserves the right to request any other document enabling it to verify the tenderer's economic and financial capacity.

### **2.3.2. Technical and professional capacity criteria and evidence**

#### **a. Criteria relating to tenderers**

Tenderers (in case of a joint tender the combined capacity of all tenderers) must comply with the following criteria:

- The tenderer must prove that they are able to machine materials like brass and copper with at least one project delivered in this field in the last four years with a minimum value for each project of € 40000.
- The tenderer must prove experience of working in English language with at least one project delivered in the last four years showing the necessary language coverage.
- The tenderer must prove capacity to draft reports in English.

#### **b. Criteria relating to the team delivering the service:**

The team delivering the service should include, as a minimum, the following profiles:

- at least a mechanical engineer with more than 3 years professional experience.

#### **c. Evidence:**

The tenderer confirms that it meets the selection criteria under 2.3.2 by signing the declaration on honour attached to this invitation to tender (Annex 2).

### **2.4. Technical offer**

The technical offer must cover all aspects and tasks required in the technical specifications and provide all the information needed to apply the award criteria. Offers deviating from the requirements or not covering all requirements may be excluded on the basis of non-conformity with the tender specifications and not evaluated

### **2.5. Financial offer**

The price for the tender must be quoted in euro. Tenderers from countries outside the euro zone have to quote their prices in euro. The price quoted may not be revised in line with

exchange rate movements. It is for the tenderer to assume the risks or the benefits deriving from any variation.

Prices must be quoted free of all duties, taxes and other charges, including VAT, as the European Union is exempt from such charges under Articles 3 and 4 of the Protocol on the privileges and immunities of the European Union. The amount of VAT may be shown separately.

The quoted price must be a fixed amount which includes all charges (including travel and subsistence). Travel and subsistence expenses are not refundable separately.

## 2.6. Award of the contract

The tender will be awarded to the tenderer offering the lowest price.

## 3. TECHNICAL SPECIFICATIONS

	Quantity
two piece cup seals, brass and copper (3/4" diameter) numbered from EUR 600,001 to EUR 620,000	20,000
two piece cup seals, brass and copper (3/4" diameter) numbered from EUR/C 700,001 IAEA to EUR/C 720,000 IAEA	20,000

The top of the seal has to be stamped (according to *Pictures 1, 2, 3* annexed). The base of the seal has to have two pierced holes (according to *Pictures 2, 3, 4* annexed); seal wire of 1.4 mm should pass.

Stamps with seals numbers on the 3/4" copper cups of seals should be as large as possible (approximately 1/8" high, 5/8" long), characters must be stamped sufficiently strongly, so they can be easily read (according to *Picture 3* annexed).

Material: brass and copper, brass teeth, 2-.070

Precise sizes of seals (in detail) are given in *Drawings Nr.0001-0004* annexed to this Technical Specifications.

The seals must be packed carefully: 20 to a carton. They should be in consecutive order: the last digit of the first seal being 1, and the last digit of the 20<sup>th</sup> seal being 0.

Please see all pictures and drawings.



*Picture 1*



*Picture 2*

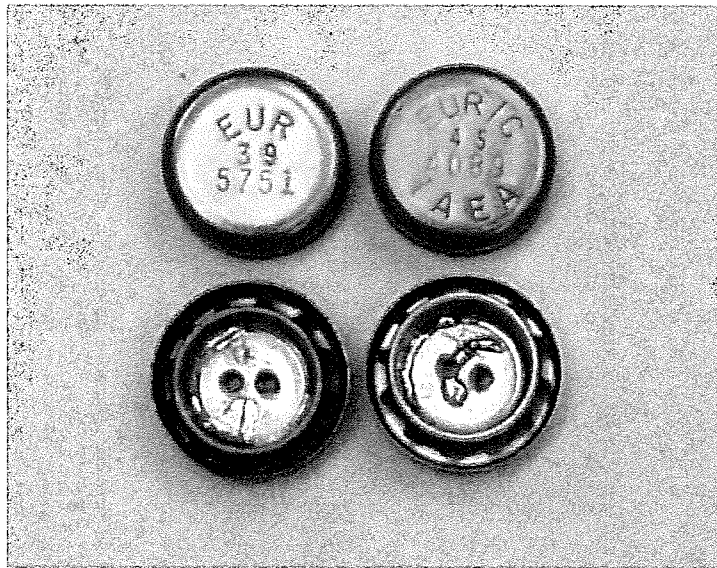

*Picture 3*

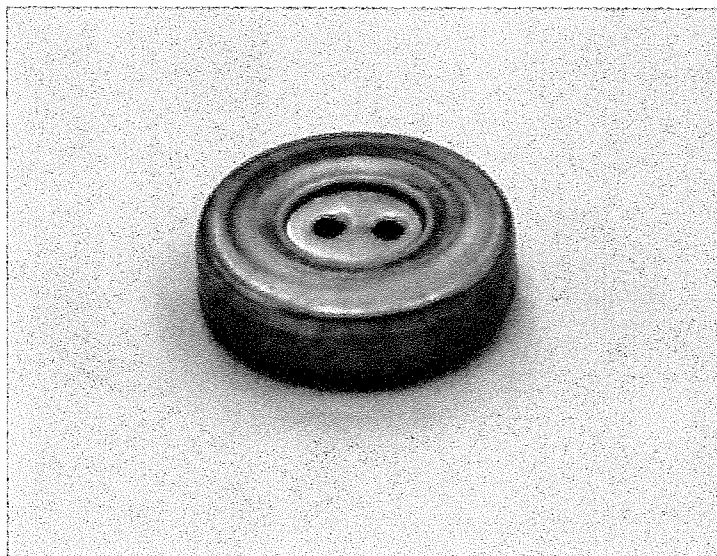

*Picture 4*

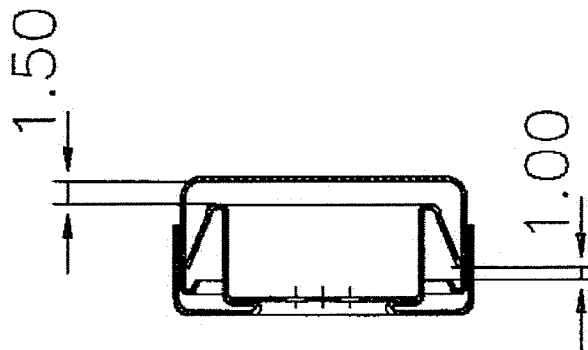
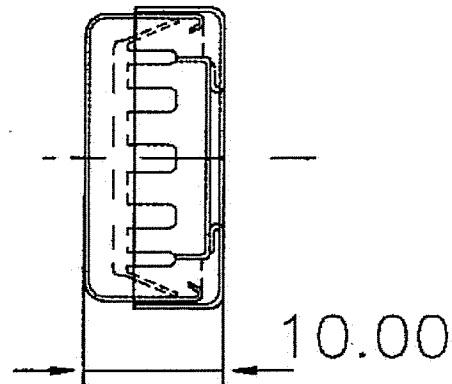
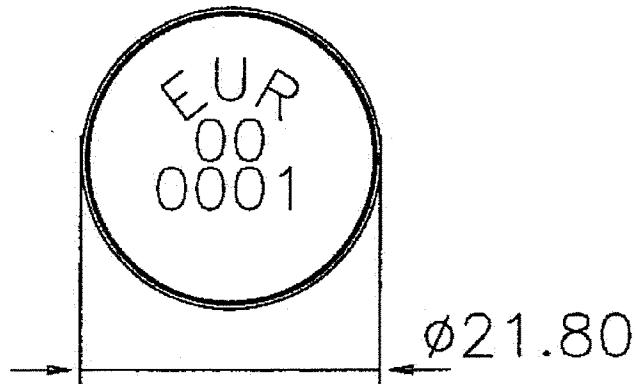

Seal EURATOM  
gen. tolerances  $\pm 0.2$   
material: copper-brass

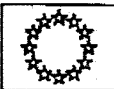
DG TREN bat.CUBE	Drawing No 0001	Date: 21/08/03
SEALS Laboratory	Draw: MASELLI	Scale: 2-1
	EUROPEAN COMMISSION LUXEMBOURG	

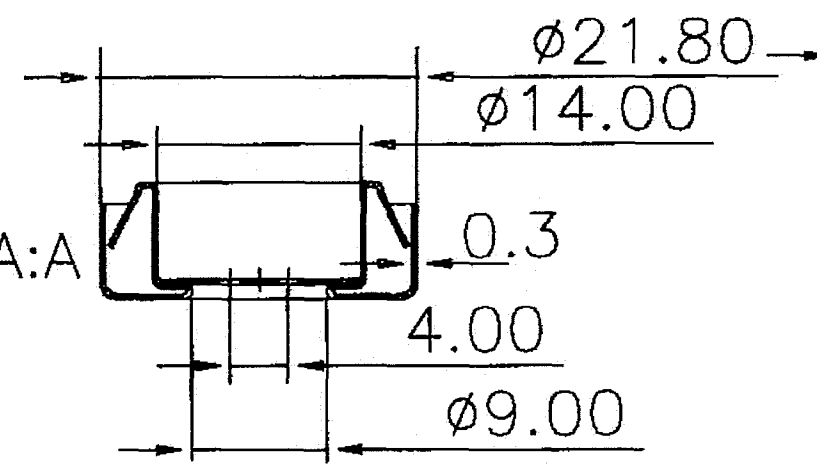
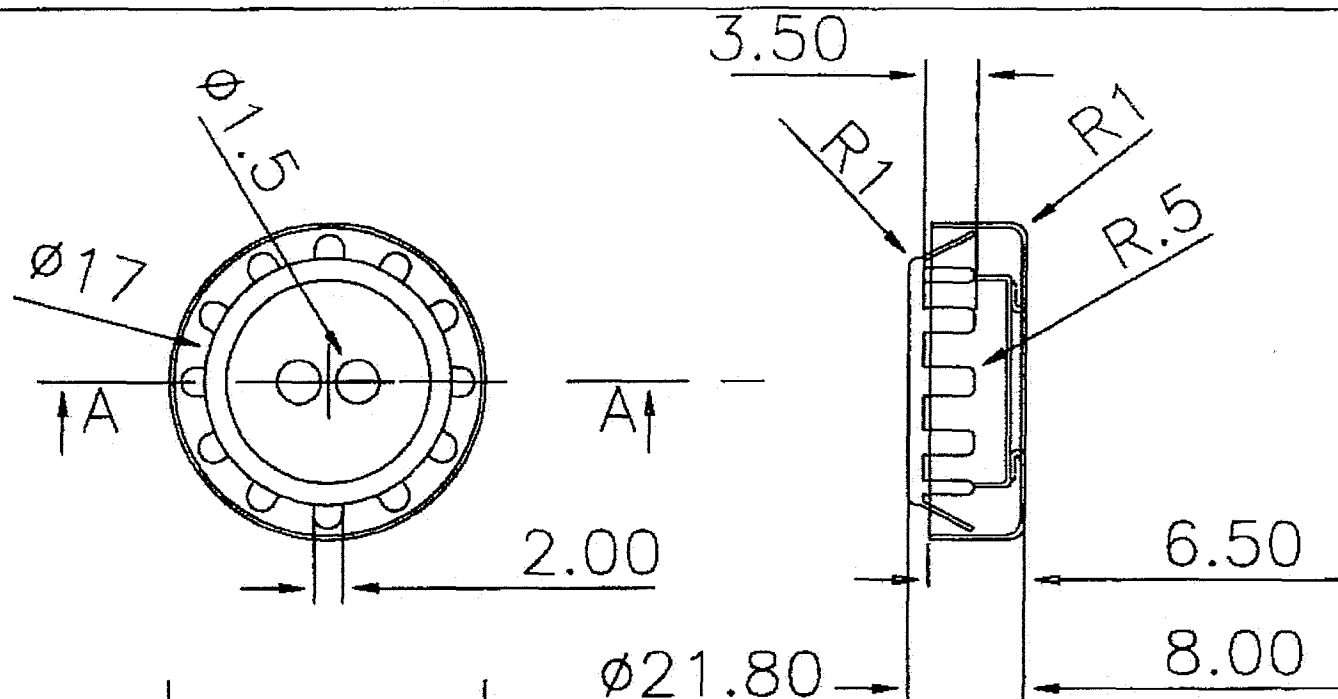

Sect. A:A

Seal base  
 gen. tolerances  $\pm 0.2$   
 material: brass

DG TREN bat.CUBE	Drawing No 0002	Date: 21/08/01
SEALS Laboratory	Draw: Maselli	Scale: 2-1
	EUROPEAN COMMISSION LUXEMBOURG	

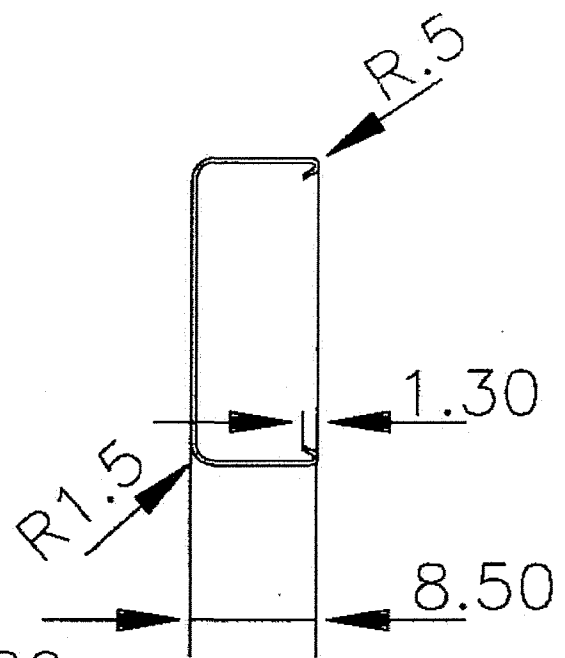
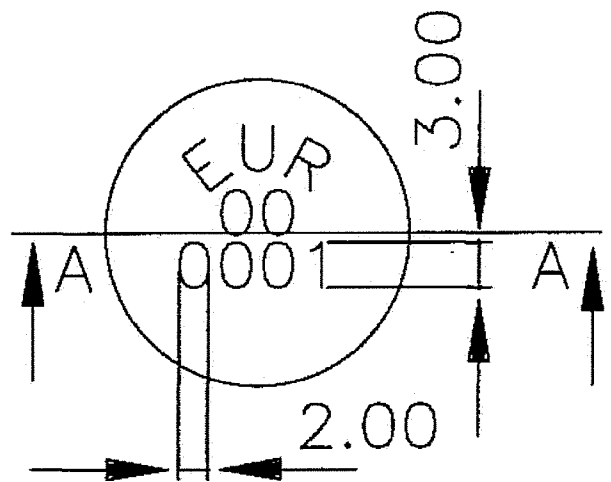

Sect. A:A

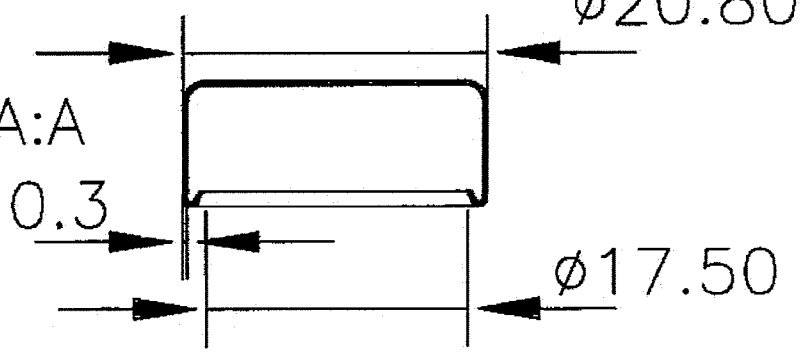

Seal top  
gen. tolerances  $\pm 0.2$   
material: copper

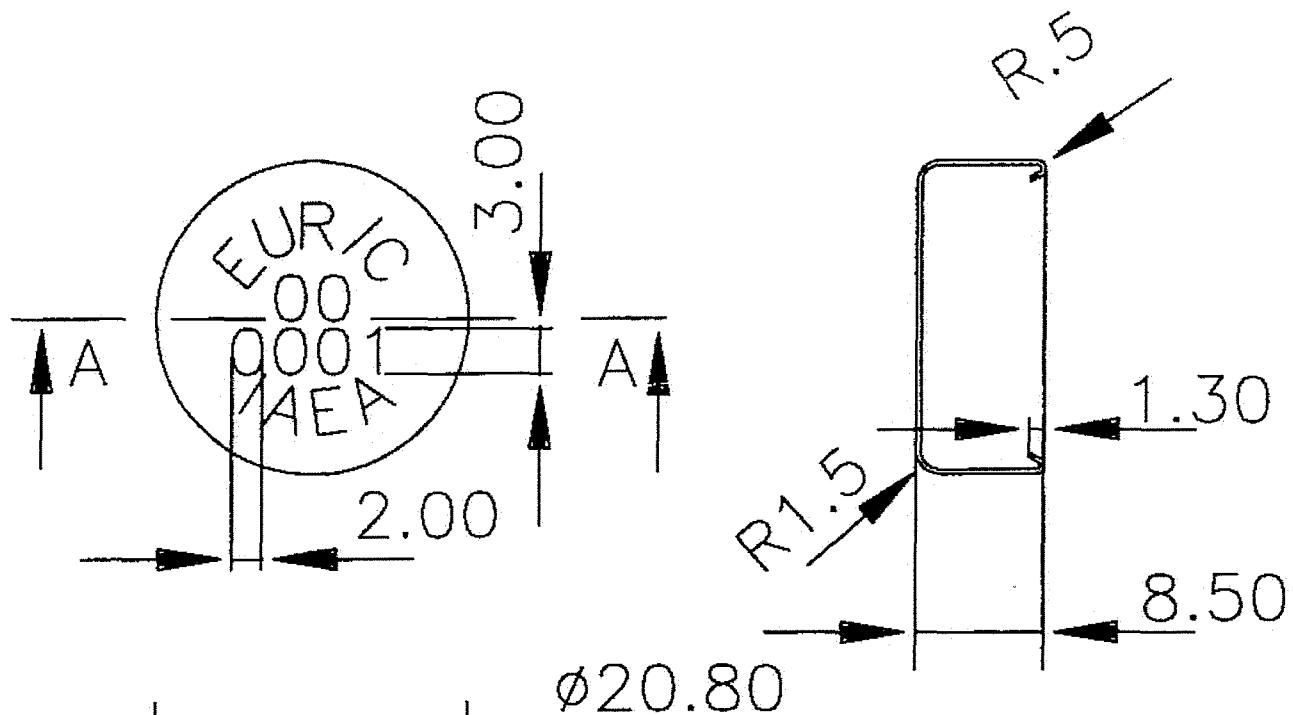

DG TREN bat.CUBE	Drawing No 0003	Date:21/08/03
SEALS Laboratory	Draw: Maselli	Scale:2-1
 EUROPEAN COMMISSION LUXEMBOURG		

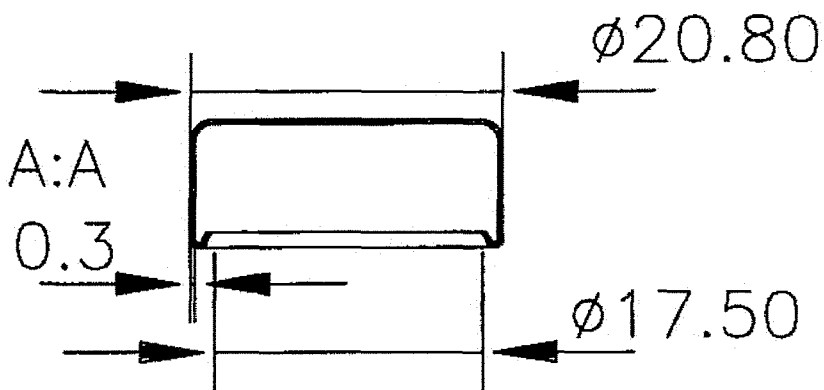

Sect. A:A



Seal top  
 gen. tolerances  $\pm 0.2$   
 material: copper

DG TREN bat.CUBE	Drawing No 0004	Date:21/08/03
SEALS Laboratory	Draw: MASELLI	Scale:2-1
 EUROPEAN COMMISSION LUXEMBOURG		



#### **4. ANNEXES**

1. Tenderer 's Identification Form
2. Declaration related to the exclusion and selection criteria and absence of conflict of interest
3. Power of attorney (mandate in case of joint tender)
4. Draft Contract

# ANNEX 1

## IDENTIFICATION OF THE TENDERER

(Each service provider, including any member of a consortium or grouping and subcontractor(s) whose share of the work is more than 20% of the contract must complete and sign this identification form)

### Call for tenders ENER/E1/2015-37-11

<b>Identity</b>	
Name of the tenderer	
Legal status of the tenderer	
Date of registration	
Country of registration	
Registration number	
VAT number	
Description of statutory social security cover (at the level of the Member State of origin) and non-statutory cover (supplementary professional indemnity insurance) <sup>2</sup>	
<b>Address</b>	
Address of registered office of tenderer	
Where appropriate, administrative address of tenderer for the purposes of this invitation to tender	
<b>Contact Person</b>	
Surname:	
First name:	
Title (e.g. Dr, Mr, Ms) :	
Position (e.g. manager):	
Telephone number:	
Fax number:	
E-mail address:	

<sup>2</sup> For natural persons

<b>Legal Representatives</b>	
<b>Names and function of legal representatives</b> and of other representatives of the tenderer who are authorised to sign contracts with third parties	
<b>Declaration by an authorised representative of the organisation<sup>3</sup></b>	
I, the undersigned, certify that the information given in this tender is correct and that the tender is valid.	
Surname: First name:	Signature:

---

<sup>3</sup> This person must be included in the list of legal representatives; otherwise the signature on the tender will be invalidated.

## ANNEX 2

### Declaration of honour on exclusion and selection criteria, and absence of conflict of interest

*(Complete or delete the parts in grey italics in parentheses)*

*[Choose options for parts in grey between square brackets]*

The undersigned (*insert name of the signatory of this form*):

in *[his][her]* own name (*for a natural person*)

or

representing the following legal person: (*only if the economic operator is a legal person*)

full official name:

official legal form:

full official address:

VAT registration number:

➤ declares that *[the above-mentioned legal person][he][she]* is not in one of the following situations:

- a) is bankrupt or being wound up, is having its affairs administered by the courts, has entered into an arrangement with creditors, has suspended business activities, is the subject of proceedings concerning those matters, or is in any analogous situation arising from a similar procedure provided for in national legislation or regulations;
- b) has been convicted of an offence concerning professional conduct by a judgment of a competent authority of a Member State which has the force of *res judicata*;
- c) has been guilty of grave professional misconduct proven by any means which the contracting authorities can justify including by decisions of the European Investment Bank and international organisations;
- d) is not in compliance with all its obligations relating to the payment of social security contributions and the payment of taxes in accordance with the legal provisions of the country in which it is established, with those of the country of the contracting authority and those of the country where the contract is to be performed;
- e) has been the subject of a judgement which has the force of *res judicata* for fraud, corruption, involvement in a criminal organisation, money laundering or any other illegal activity, where such activity is detrimental to the Union's financial interests;
- f) is a subject of an administrative penalty for being guilty of misrepresentation in supplying the information required by the contracting authority as a condition of participation in a procurement procedure or failing to supply this information, or having been declared to be in serious breach of its obligations under contracts covered by the Union's budget.

➤ (*Only for legal persons other than Member States and local authorities, otherwise delete*) declares that the natural persons with power of representation, decision-making

or control<sup>4</sup> over the above-mentioned legal entity are not in the situations referred to in b) and e) above;

➤ declares that [the above-mentioned legal person][he][she]:

- g) has no conflict of interest in connection with the contract; a conflict of interest could arise in particular as a result of economic interests, political or national affinity, family, emotional life or any other shared interest;
- h) will inform the contracting authority, without delay, of any situation considered a conflict of interest or which could give rise to a conflict of interest;
- i) has not granted and will not grant, has not sought and will not seek, has not attempted and will not attempt to obtain, and has not accepted and will not accept any advantage, financial or in kind, to or from any party whatsoever, where such advantage constitutes an illegal practice or involves corruption, either directly or indirectly, inasmuch as it is an incentive or reward relating to award of the contract;
- j) provided accurate, sincere and complete information to the contracting authority within the context of this procurement procedure ;
  - acknowledges that [the above-mentioned legal person][he][she] may be subject to administrative and financial penalties<sup>5</sup> if any of the declarations or information provided prove to be false.
- k) meets the selection criteria as mentioned in the tender specifications under 2.3.2

Full name

Date

Signature

---

<sup>4</sup> This covers the company directors, members of the management or supervisory bodies, and cases where one natural person holds a majority of shares.

<sup>5</sup> As provided for in Article 109 of the Financial Regulation (EU, Euratom) 966/2012 and Article 145 of the Rules of Application of the Financial Regulation

# ANNEX 3

## POWER OF ATTORNEY

**mandating one of the partners in a joint tender as lead partner and lead contractor<sup>6</sup>**

The undersigned:

— Signatory (Name, Function, Company, Registered address, VAT Number)

having the legal capacity required to act on behalf of his/her company,

HEREBY AGREES TO THE FOLLOWING:

- 1) To submit a tender as a partner in the group of partners constituted by Company 1, Company 2, Company N, and led by Company X, in accordance with the conditions specified in the tender specifications and the terms specified in the tender to which this power of attorney is attached.
- 2) If the European Commission awards the Contract to the group of partners constituted by Company 1, Company 2, Company N, and led by Company X on the basis of the joint tender to which this power of attorney is attached, all the partners shall be co-signatories of the Contract in accordance with the following conditions:
  - (a) All partners shall be jointly and severally liable towards the European Commission for the performance of the Contract.
  - (b) All partners shall comply with the terms and conditions of the Contract and ensure the proper delivery of their respective share of the services and/or supplies subject to the Contract.
- 1) Payments by the European Commission related to the services and/or supplies subject to the Contract shall be made through the lead partner's bank account: [Provide details on bank address, account number].
- 2) The partners grant to the lead partner all the necessary powers to act on their behalf in the submission of the tender and conclusion of the Contract, including:
  - (a) The lead partner shall submit the tender on behalf of the group of partners.
  - (b) The lead partner shall sign any contractual documents — including the Contract, and Amendments thereto — and issue any invoices related to the Services on behalf of the group of partners.
  - (c) The lead partner shall act as a single contact point with the European Commission in the delivery of the services and/or supplies subject to the Contract. It shall co-ordinate the delivery of the services and/or supplies by the group of partners to the European Commission, and shall see to a proper administration of the Contract.

Any modification to the present power of attorney shall be subject to the European Commission's express approval. This power of attorney shall expire when all the contractual obligations of the group of partners towards the European Commission for the delivery of the services and/or supplies subject to the Contract have ceased to exist. The parties cannot terminate it before that date without the Commission's consent.

Signed in ..... on [dd/mm/yyyy]

Place and date:

Name (in capital letters), function, company and signature:

<sup>6</sup> To be filled in and signed by each partner in a joint tender, except the lead partner;



EUROPEAN COMMISSION  
DIRECTORATE-GENERAL FOR ENERGY

Directorate E - Euratom Safeguards  
E.1 - Quality assurance and technology

## ANNEX 4

# SUPPLY CONTRACT

CONTRACT NUMBER – [complete]

The European Atomic Energy Community (hereinafter referred to as "the Community"), represented by the European Commission (hereinafter referred to as "the contracting authority"), which is represented for the purposes of the signature of this contract by Mr. Piotr Szymanski, Director in the Directorate-General for Energy, Directorate E, EURATOM Safeguards,

on the one part, and

[full official name]

[official legal form]

[statutory registration number]

[full official address]

[VAT registration number]

[(hereinafter referred to as 'the contractor'),][represented for the purposes of the signature of this contract by [forename, surname and function,]]

[The parties identified above and hereinafter collectively referred to as 'the contractor' shall be jointly and severally liable vis-à-vis the contracting authority for the performance of this contract.]

on the other part

HAVE AGREED

To the **special conditions**, the **general conditions for supply contracts** and the following annexes:

**Annex I** Tender specifications (reference No [complete] of [insert date])

**Annex II** contractor's tender (reference No [complete] of [insert date])

[Other annexes]

which form an integral part of this contract (hereinafter referred to as “the contract”).

- The terms set out in the special conditions shall take precedence over those in the other parts of the contract.
- The terms set out in the general conditions shall take precedence over those in the other annexes.
- The terms set out in the tender specifications (Annex I) shall take precedence over those in the tender (Annex II).



## I – SPECIAL CONDITIONS

### **ARTICLE I.1 – SUBJECT MATTER**

- I.1.1** The subject matter of the contract is the acquisition of 40000 two piece cup seals, brass and copper.
- I.1.2** The contractor shall deliver the supplies in accordance with the tender specifications annexed to the contract (Annex I).

### **ARTICLE I.2 – ENTRY INTO FORCE, DURATION AND DELIVERY**

- I.2.1** The contract shall enter into force on the date on which it is signed by the last party.
- I.2.2** Under no circumstances may implementation commence before the date on which the contract enters into force.
- I.2.3** Delivery of supplies shall take place immediately after the entry into force of the contract. Unless otherwise specified, all periods specified in the contract are calculated in calendar days.
- I.2.4** The supplies shall be delivered at:

European Commission  
Directorate-Energy  
Direction E - EURATOM Safeguards  
Complexe Euroforum  
1, rue Henry M. Schnadt  
Zone d'activités Cloche d'Or  
L-2530 Luxembourg  
To the attention of: Mr Leonardo ARTESE (tel: 00352 4301-34707) / Mr Stephane TEMPESTA (tel: 00352 4301-31697),

The contractor shall notify the contracting authority of the exact date of delivery at least 10 days in advance. All deliveries shall be made between 09:00 hours and 12:00 hours at the agreed place of delivery.

### **ARTICLE I.3 - PRICE**

- I.3.1** The maximum total amount to be paid by the contracting authority under the contract shall be EUR [*amount in figures and in words*] covering the delivery of all the supplies.

### **ARTICLE I.4 –PAYMENT ARRANGEMENTS**

#### **I.4.1 Payment of the balance**

The contractor shall submit an invoice for payment of the balance.

The invoice shall be accompanied by the final progress report or any other document in accordance with the tender specifications. The contracting authority shall make the payment within 90 days from receipt of the invoice. The contractor shall have

20 days in which to submit additional information or corrections, a new progress report or other documents if required by the contracting authority.]

\*\*\*

[Where VAT is due in Belgium, the provisions of the contract constitute a request for VAT exemption No 450, Article 42, paragraph 3.3 of the VAT code (circular 2/1978), provided the contractor includes the following statement in the invoice(s): “Exonération de la TVA, Article 42, paragraphe 3.3 du code de la TVA (circulaire 2/1978)” or an equivalent statement in the Dutch or German language.]

[Where VAT is due in Luxembourg, the contractor shall include the following statement in the invoices: "Commande destinée à l'usage officiel de l'Union européenne. Exonération de la TVA Article 43 § 1 k 2ième tiret de la loi modifiée du 12.02.79." In case of intra-Community purchases, the statement to be included in the invoices is: "For the official use of the European Union. VAT Exemption / European Union/ Article 151 of Council Directive 2006/112/EC."]

### **ARTICLE I.5 – BANK ACCOUNT**

Payments shall be made to the contractor’s bank account denominated in euro, identified as follows:

Name of bank:  
 Full address of branch:  
 Exact designation of account holder:  
 Full account number including [bank] codes:  
 [IBAN<sup>7</sup> code:]

### **ARTICLE I.6 – COMMUNICATION DETAILS AND DATA CONTROLLER**

For the purpose of Article II.6, the data controller shall be the Director of the Shared Resource Directorate MOVE/ENER.

Communications shall be sent to the following addresses:

Contracting authority:  
 European Commission  
 Directorate -Energy  
 Direction E - EURATOM Safeguards  
 Complexe Euroforum  
 1, rue Henry M. Schnadt  
 Zone d'activités Cloche d'Or  
 L-2530 Luxembourg

Contractor:  
 [Mr/Mrs/Ms]  
 [Function]  
 [Company name]  
 [Full official address]  
 Email: [complete]

---

<sup>7</sup> BIC or SWIFT code for countries with no IBAN code.

**ARTICLE I.7 - APPLICABLE LAW AND SETTLEMENT OF DISPUTES**

- I.7.1 The contract shall be governed by Community and Union law, complemented, where necessary, by the law of Luxembourg.
- I.7.2 Any dispute between the parties resulting from the interpretation, application or validity of the contract which cannot be settled amicably shall be brought before the courts of Luxembourg.

**ARTICLE I.8 – TERMINATION BY EITHER PARTY**

Either party may, unilaterally and without being required to pay compensation, terminate the contract by formally notifying the other party by giving [one month's] notice. Should the contracting authority terminate the contract, the contractor shall only be entitled to payment corresponding to the supplies delivered before the termination date. The first paragraph of Article II.13.3 shall apply.

**SIGNATURES**

For the contractor,  
[Company name/forename/surname/function]

For the contracting authority,  
[forename/surname/function]

signature[s]: \_\_\_\_\_

signature[s]: \_\_\_\_\_

Done at [Brussels], [date]  
In duplicate in English.

Done at Luxembourg, [date]

## **II – GENERAL CONDITIONS FOR SUPPLY CONTRACTS**

### **ARTICLE II.1 – PERFORMANCE OF THE CONTRACT**

#### **II.1.1 Delivery**

(a) Time allowed for delivery

The time allowed for delivery shall be calculated in accordance with Article I.2.

(b) Date, time and place of delivery

The contracting authority shall be notified in writing of the exact date of delivery within the period indicated in Article I.2. All deliveries shall be made at the agreed place of delivery during the hours indicated in Article I.2.

The contractor shall bear all costs and risks involved in delivering the supplies to the place of delivery.

(c) Consignment note

Each delivery shall be accompanied by a consignment note in duplicate, duly signed and dated by the contractor or its carrier, giving the contract number and particulars of the supplies delivered. One copy of the consignment note shall be countersigned by the contracting authority and returned to the contractor or to its carrier.

#### **II.1.2 Certificate of conformity**

Signature of the consignment note by the contracting authority, as provided for in point (c) of Article II.1.1 is simply an acknowledgment of the fact that the delivery took place and in no way implies conformity of the supplies with this contract.

Conformity of the supplies delivered shall be evidenced by the signature of a certificate to this effect by the contracting authority no later than one month after the date of delivery, unless otherwise specified in the special conditions or in the tender specifications (Annex I).

Conformity shall be declared only where the conditions laid down in the contract are satisfied and the supplies conform to the tender specifications (Annex I).

Where, for reasons attributable to the contractor, the contracting authority is unable to accept the supplies, the contractor shall be notified in writing at the latest by the deadline for conformity.

#### **II.1.3 Conformity of the supplies delivered with the contract**

(a) The supplies delivered by the contractor to the contracting authority must be in conformity in quantity, quality, price and packaging with this contract.

(b) The supplies delivered must:

(i) correspond to the description given in the tender specifications (Annex I) and possess the characteristics of the supplies provided by the contractor to the contracting authority as a sample or model;

(ii) be fit for any specific purpose required of them by the contracting authority and made known to the contractor at the time of conclusion of this contract and accepted by the contractor;

(iii) be fit for the purposes for which supplies of the same type are normally used;

- (iv) demonstrate the quality and performance which are normal in supplies of the same type and which the contracting authority can reasonably expect, given the nature of the supplies and taking into account any public statements on the specific characteristics of the supplies made by the contractor, the producer or its representative, particularly in advertising or on labelling;
- (v) be packaged according to the usual method for supplies of the same type or, failing this, in a way designed to preserve and protect them.

#### **II.1.4 Remedy**

- (a) The contractor shall be liable to the contracting authority for any lack of conformity which exists at the time the supplies are verified.
- (b) In case of lack of conformity, without prejudice to Article II.11 regarding liquidated damages applicable to the total price of the supplies concerned, the contracting authority shall be entitled:
  - (i) either to have the supplies brought into conformity, free of charge, by repair or replacement;
  - (ii) or to have an appropriate reduction made in the price.
- (c) Any repair or replacement shall be completed within a reasonable time and without any significant inconvenience to the contracting authority, taking account of the nature of the supplies and the purpose for which they are required by the contracting authority.
- (d) The term 'free of charge' in paragraph (b) refers to the costs incurred to bring the supplies into conformity, particularly the cost of postage, labour and materials.

#### **II.1.5 Assembly**

If required by Article I.1.2, the contractor shall assemble the supplies delivered within a period of one month unless otherwise specified in the special conditions or in the tender specifications (Annex I).

Any lack of conformity resulting from incorrect installation of the supplies delivered shall be deemed to be equivalent to lack of conformity of the supplies if installation forms part of this contract and the supplies were installed by the contractor or under its responsibility. This shall apply equally if the product was to be installed by the contracting authority and was incorrectly installed owing to a shortcoming in the installation instructions.

#### **II.1.6 Services provided to supplies**

If required by Article I.1.2 or the tender specifications (Annex I), services to supplies shall be provided accordingly.

#### **II.1.7 General provisions concerning supplies**

- (a) Packaging

The supplies shall be packaged in strong boxes or crates or in any other way that ensures that the contents remain intact and prevents damage or deterioration. Packaging, pallets, etc., including contents, shall not weigh more than 500 kg.

Unless otherwise specified in the special conditions or in the tender specifications (Annex I), pallets shall be considered as one-way packaging and shall not be returned. Each box shall be clearly labelled with the following information:

- (i) name of contracting authority and address for delivery;
- (ii) name of contractor;
- (iii) description of contents;
- (iv) date of delivery;
- (v) EC code number of article.

(b) Guarantee

The supplies shall be guaranteed against all defects in manufacture or materials for two years from the date of delivery, unless provision is made for a longer period in the tender specifications (Annex I).

The contractor shall guarantee that any permits and licences required for manufacturing and selling the supplies have been obtained.

The contractor shall replace at its own expense, within a reasonable time limit to be determined by agreement between the parties, any items which become damaged or defective in the course of normal use during the guarantee period.

The contractor is responsible for any conformity defect which exists at the time of delivery, even if this defect does not appear until a later date.

The contractor is also responsible for any conformity defect which occurs after delivery and is ascribable to non-compliance with its obligations, including failure to provide a guarantee that, for a certain period, supplies used for the purposes for which they are normally used or for a specific purpose will preserve their qualities or characteristics as specified.

If part of an item is replaced, the replacement part shall be guaranteed under the same terms and conditions for a further period of the same duration as that specified above.

If a defect is found to originate in a systematic flaw in design, the contractor must replace or modify all identical parts incorporated in the other supplies that are part of the contract, even though they may not have been the cause of any incident. In this case, the guarantee period shall be extended as stated above.

### **II.1.8 General provisions on performance of the contract**

- (a) The contractor shall perform the contract to the highest professional standards.
- (b) The contractor shall be solely responsible for taking the necessary steps to obtain any permit or licence required for performance of the contract under the laws and regulations in force at the place where the tasks assigned to it are to be executed.
- (c) Without prejudice to Article II.5 any reference made to the contractor's personnel in the contract shall relate exclusively to individuals involved in the performance of the contract.

- (d) The contractor must ensure that any personnel performing the contract possesses the professional qualifications and experience required for execution of the tasks assigned to it.
- (e) The contractor shall neither represent the contracting authority nor behave in any way that would give such an impression. The contractor shall inform third parties that it does not belong to the European public service.
- (f) The contractor shall be solely responsible for the personnel who executes the tasks assigned to the contractor.

The contractor shall stipulate the following employment or service relationships with its personnel:

- (i) personnel executing the tasks assigned to the contractor may not be given orders directly by the contracting authority;
  - (ii) the contracting authority may not under any circumstances be considered to be the employer of the personnel referred to in point (i) and the personnel shall undertake not to invoke against the contracting authority any right arising from the contractual relationship between the contracting authority and the contractor.
- (g) In the event of disruption resulting from the action of one of the contractor's personnel working on the contracting authority's premises or in the event that the expertise of a member of the contractor's personnel fails to correspond to the profile required by the contract, the contractor shall replace him without delay. The contracting authority shall have the right to make a reasoned request for the replacement of such personnel. The replacement personnel must have the necessary qualifications and be capable of performing the contract under the same contractual conditions. The contractor shall be responsible for any delay in the execution of the tasks assigned to it resulting from the replacement of personnel.
  - (h) Should the execution of the contract be directly or indirectly hampered, either partially or totally, by any unforeseen event, action or omission, the contractor shall immediately and at its own initiative record it and report it to the contracting authority. The report shall include a description of the problem and an indication of the date on which it started and of the remedial action taken by the contractor to ensure full compliance with its obligations under this contract. In such an event the contractor shall give priority to solving the problem rather than determining liability.
  - (i) Should the contractor fail to perform its obligations under the contract, the contracting authority may - without prejudice to its right to terminate the contract - reduce or recover payments in proportion to the scale of the unperformed obligations. In addition, the contracting authority may claim compensation or impose liquidated damages in accordance with Article II.11.

## **ARTICLE II.2 – MEANS OF COMMUNICATION**

- II.2.1** Any communication relating to the contract or to its performance shall be made in writing and shall bear the contract number. Any communication is deemed to have been made when it is received by the receiving party unless otherwise provided for in this contract.
- II.2.2** Electronic communication shall be deemed to have been received by the parties on the day of dispatch of that communication provided it is sent to the addressees listed in

Article I.6. Without prejudice to the preceding, if the sending party receives a message of non-delivery to or of absence of the addressee, it shall make every effort to ensure the actual receipt of such communication by the other party.

Electronic communication shall be confirmed by an original signed paper version of that communication if requested by any of the parties provided that this request is submitted without unjustified delay. The sender shall send the original signed paper version without unjustified delay.

**II.2.3** Mail sent using the postal services is deemed to have been received by the contracting authority on the date on which it is registered by the department responsible referred to in Article I.6.

Any formal notification shall be made by registered mail with return receipt or equivalent, or by equivalent electronic means.

### **ARTICLE II.3 - LIABILITY**

**II.3.1** The contractor shall be solely responsible for complying with any legal obligations incumbent on it.

**II.3.2** The contracting authority shall not be held liable for any damage caused or sustained by the contractor, including any damage caused by the contractor to third parties during or as a consequence of performance of the contract, except in the event of wilful misconduct or gross negligence on the part of the contracting authority.

**II.3.3** The contractor shall be liable for any loss or damage sustained by the contracting authority in performance of the contract, including in the event of subcontracting, and for any claim by a third party, but only to an amount not exceeding three times the total amount of the contract. Nevertheless, if the damage or loss is caused by the gross negligence or wilful misconduct of the contractor or of its personnel, the contractor shall have unlimited liability for the amount of the damage or loss.

**II.3.4** The contractor shall indemnify and hold the Community harmless for all damages and costs incurred due to any claim. The contractor shall provide compensation in the event of any action, claim or proceeding brought against the contracting authority by a third party as a result of damage caused by the contractor during the performance of the contract. In the event of any action brought by a third party against the contracting authority in connection with the performance of the contract, the contractor shall assist the contracting authority. Such expenditure incurred by the contractor may be borne by the contracting authority.

**II.3.5** The contractor shall take out an insurance policy against risks and damage relating to the performance of the contract, if required by the relevant applicable legislation. It shall take out supplementary insurance as reasonably required by standard practice in the industry. A copy of all the relevant insurance contracts shall be sent to the contracting authority should it so request.

### **ARTICLE II.4 - CONFLICT OF INTERESTS**

**II.4.1** The contractor shall take all the necessary measures to prevent any situation of conflict of interest. Such situation arises where the impartial and objective performance of the contract is compromised for reasons involving economic interest, political or national affinity, family or emotional ties, or any other shared interest.

**II.4.2** Any situation constituting or likely to lead to a conflict of interest during the performance of the contract shall be notified to the contracting authority in writing without delay. The contractor shall immediately take all the necessary steps to rectify the situation. The contracting authority reserves the right to verify that the steps taken



are appropriate and may require that additional steps be taken within a specified deadline.

**II.4.3** The contractor declares that it has not granted and will not grant, has not sought and will not seek, has not attempted and will not attempt to obtain and has not accepted and will not accept, any advantage, financial or in kind, to or from any party whatsoever, when such advantage constitutes an illegal practice or involves corruption, either directly or indirectly, in so far as it serves as an incentive or reward relating to the performance of the contract.

**II.4.4** The contractor shall pass on all the relevant obligations in writing to its personnel and to any natural person with the power to represent it or take decisions on its behalf and ensure that it is not placed in a situation which could give rise to conflicts of interest. The contractor shall also pass on all the relevant obligations in writing to third parties involved in the performance of the contract including subcontractors.

## **ARTICLE II.5 – CONFIDENTIALITY**

**II.5.1** The contracting authority and the contractor shall treat with confidentiality any information and documents, in any form, disclosed in writing or orally in relation to the performance of the contract and identified in writing as confidential.

The contractor shall:

- (a) not use confidential information and documents for any purpose other than fulfilling its obligations under the contract without prior written agreement of the contracting authority;
- (b) ensure the protection of such confidential information and documents with the same level of protection it uses to protect its own confidential information, but in no case any less than reasonable care;
- (c) not disclose directly or indirectly confidential information and documents to third parties without prior written agreement of the contracting authority.

**II.5.2** The confidentiality obligation set out in Article II.5.1 shall be binding on the contracting authority and the contractor during the performance of the contract and for five years starting from the date of the payment of the balance unless:

- (a) the disclosing party agrees to release the other party from the confidentiality obligation earlier;
- (b) the confidential information becomes public through other means than in breach of the confidentiality obligation, through disclosure by the party bound by that obligation;
- (c) the disclosure of the confidential information is required by law.

**II.5.3** The contractor shall obtain from any natural person with the power to represent it or take decisions on its behalf, as well as from third parties involved in the performance of the contract, an undertaking that they will comply with the confidentiality obligation set out in Article II.5.1.

## **Article II.6 – Processing of personal data**

**II.6.1** Any personal data included in the contract shall be processed pursuant to Regulation (EC) 45/2001 of the European Parliament and of the Council of 18 December 2000 on the protection of individuals with regard to the processing of personal data by the Community institutions and bodies and on the free movement of such data. Such data

shall be processed by the data controller solely for the purposes of the performance, management and monitoring of the contract without prejudice to its possible transmission to the bodies charged with monitoring or inspection tasks in application of the Community and Union law.

- II.6.2** The contractor shall have the right to access its personal data and the right to rectify any such data. The contractor should address any queries concerning the processing of its personal data to the data controller.
- II.6.3** The contractor shall have right of recourse at any time to the European Data Protection Supervisor.
- II.6.4** Where the contract requires the processing of personal data by the contractor, the contractor may act only under the supervision of the data controller, in particular with regard to the purposes of the processing, the categories of data which may be processed, the recipients of the data and the means by which the data subject may exercise his rights.
- II.6.5** The contractor shall grant its personnel access to the data to the extent strictly necessary for the performance, management and monitoring of the contract.
- II.6.6** The contractor undertakes to adopt appropriate technical and organisational security measures having regard to the risks inherent in the processing and to the nature of the personal data concerned in order to:
- (a) prevent any unauthorised person from gaining access to computer systems processing personal data, and especially:
    - (i) unauthorised reading, copying, alteration or removal of storage media;
    - (ii) unauthorised data input, as well as any unauthorised disclosure, alteration or erasure of stored personal data;
    - (iii) unauthorised use of data-processing systems by means of data transmission facilities;
  - (b) ensure that authorised users of a data-processing system can access only the personal data to which their access right refers;
  - (c) record which personal data have been communicated, when and to whom;
  - (d) ensure that personal data being processed on behalf of third parties can be processed only in the manner prescribed by the contracting authority;
  - (e) ensure that, during communication of personal data and transport of storage media, the data cannot be read, copied or erased without authorisation;
  - (f) design its organisational structure in such a way that it meets data protection requirements.

## **ARTICLE II.7 – SUBCONTRACTING**

- II.7.1** The contractor shall not subcontract without prior written authorisation from the contracting authority nor cause the contract to be de facto performed by third parties.
- II.7.2** Even where the contracting authority authorises the contractor to subcontract to third parties, it shall nevertheless remain bound by its contractual obligations and shall be solely responsible for the proper performance of this contract.
- II.7.3** The contractor shall make sure that the subcontract does not affect rights and guarantees granted to the contracting authority by virtue of this contract, notably by Article II.16.

## **ARTICLE II.8 - AMENDMENTS**

- II.8.1** Any amendment to the contract shall be made in writing before fulfilment of any new contractual obligations and in any case before the date of payment of the balance.
- II.8.2** The amendment may not have the purpose or the effect of making changes to the contract which might call into question the decision awarding the contract or result in unequal treatment of tenderers.

## **ARTICLE II.9 – ASSIGNMENT**

- II.9.1** The contractor shall not assign the rights, including claims for payments, and obligations arising from the contract, in whole or in part, without prior written authorisation from the contracting authority.
- II.9.2** In the absence of such authorisation, or in the event of failure to observe the terms thereof, the assignment of rights or obligations by the contractor shall not be enforceable against the contracting authority and shall have no effect on it.

## **ARTICLE II.10– FORCE MAJEURE**

- II.10.1** 'Force majeure' means any unforeseeable and exceptional situation or event beyond the parties' control which prevents either of them from fulfilling any of their obligations under the contract, which was not attributable to error or negligence on their part or on the part of subcontractors and which proves to be inevitable in spite of exercising due diligence. Any default of a service, defect in equipment or material or delays in making them available, unless they stem directly from a relevant case of force majeure, as well as labour disputes, strikes or financial difficulties, cannot be invoked as force majeure.
- II.10.2** A party faced with force majeure shall formally notify the other party without delay, stating the nature, likely duration and foreseeable effects.
- II.10.3** The party faced with force majeure shall not be held in breach of its contractual obligations if it has been prevented from fulfilling them by force majeure. Where the contractor is unable to fulfil its contractual obligations owing to force majeure, it shall have the right to remuneration only for the tasks actually executed.
- II.10.4** The parties shall take all the necessary measures to limit any damage due to force majeure.

## **ARTICLE II.11 – LIQUIDATED DAMAGES**

The contracting authority may impose liquidated damages should the contractor fail to complete its contractual obligations, also with regard to the required quality level, according to the tender specifications.

Should the contractor fail to perform his contractual obligations within the time-limits set by the contract, then, without prejudice to the contractor's actual or potential liability incurred in relation to the contract or to the contracting authority's right to terminate the contract, the contracting authority may impose liquidated damages for each and every calendar day of delay according to the following formula:

$0.3 \times (V/d)$

$V$  is the amount specified in Article I.3.1;

$d$  is the duration specified in Article I.2.3 expressed in days

The contractor may submit arguments against this decision within 30 days of receipt of the formal notification. In the absence of a reaction on its part or of written withdrawal by the contracting authority within 30 days of the receipt of such arguments, the decision imposing the liquidated damages shall become enforceable.

The parties expressly acknowledge and agree that any sums payable under this article are in the nature of liquidated damages and not penalties, and represent a reasonable estimate of fair compensation for the losses incurred due to failure to fulfil obligations which may be reasonably anticipated.

## **ARTICLE II.12 – SUSPENSION OF THE PERFORMANCE OF THE CONTRACT**

### **II.12.1 Suspension by the contractor**

The contractor may suspend the performance of the contract or any part thereof if a case of force majeure makes such performance impossible or excessively difficult. The contractor shall inform the contracting authority about the suspension without delay, giving all the necessary reasons and details and the envisaged date for resuming the performance of the contract.

Once the circumstances allow resuming performance, the contractor shall inform the contracting authority immediately, unless the contracting authority has already terminated the contract.

### **II.12.2 Suspension by the contracting authority**

The contracting authority may suspend the performance of the contract or any part thereof:

- (a) if the contract award procedure or the performance of the contract prove to have been subject to substantial errors, irregularities or fraud;
- (b) in order to verify whether presumed substantial errors, irregularities or fraud have actually occurred.

Suspension shall take effect on the day the contractor receives formal notification, or at a later date provided in the notification. The contracting authority shall give notice as soon as possible to the contractor to resume the suspended delivery or provision of related services or inform the contractor that it is proceeding with the termination of the contract. The contractor shall not be entitled to claim compensation on account of suspension of the contract or of part thereof.

## **ARTICLE II.13 – TERMINATION OF THE CONTRACT**

### **II.13.1 Grounds for termination**

The contracting authority may terminate the contract in the following circumstances:

- (a) if a change to the contractor's legal, financial, technical or organisational or ownership situation is likely to affect the performance of the contract substantially or calls into question the decision to award the contract;
- (b) if delivery of the supplies and execution of the related tasks has not actually commenced within three months of the date foreseen, and the new date proposed, if any, is considered unacceptable by the contracting authority, taking into account Article II.8.2;
- (c) if the contractor does not perform the contract as established in the tender specifications or fails to fulfil another substantial contractual obligation;
- (d) in the event of force majeure notified in accordance with Article II.10 or if the performance of the contract has been suspended by the contractor as a result of force majeure, notified in accordance with Article II.12, where either resuming performance is impossible or the modifications to the contract might call into question the decision awarding the contract or result in unequal treatment of tenderers;
- (e) if the contractor is declared bankrupt, is being wound up, is having its affairs administered by the courts, has entered into an arrangement with creditors, has suspended business activities, is the subject of proceedings concerning those matters, or is in any analogous situation arising from a similar procedure provided for in national legislation or regulations;
- (f) if the contractor or any natural person with the power to represent it or take decisions on its behalf has been found guilty of professional misconduct proven by any means;
- (g) if the contractor is not in compliance with its obligations relating to the payment of social security contributions or the payment of taxes in accordance with the legal provisions of the country in which it is established or with those of the country of the applicable law of this contract or those of the country where the contract is to be performed;
- (h) if the contracting authority has evidence that the contractor or natural persons with the power to represent it or take decisions on its behalf have committed fraud, corruption, or are involved in a criminal organisation, money laundering or any other illegal activity detrimental to the Community's or Union's financial interests;
- (i) if the contracting authority has evidence that the contractor or natural persons with the power to represent it or take decisions on its behalf have committed substantial errors, irregularities or fraud in the award procedure or the performance of the contract, including in the event of submission of false information;
- (j) if the contractor is unable, through its own fault, to obtain any permit or licence required for performance of the contract.

### **II.13.2. Procedure for termination**

When the contracting authority intends to terminate the contract it shall formally notify the contractor of its intention specifying the grounds thereof. The contracting authority shall invite the contractor to make any observations and, in the case of point (c) of Article II.13.1,

to inform the contracting authority about the measures taken to continue the fulfilment of its contractual obligations, within 30 days from receipt of the notification.

If the contracting authority does not confirm acceptance of these observations by giving written approval within 30 days of receipt, the termination procedure shall proceed. In any case of termination the contracting authority shall formally notify the contractor about its decision to terminate the contract. In the cases referred to in points (a), (b), (c), (e), (g) and (j) of Article II.13.1 the formal notification shall specify the date on which the termination takes effect. In the cases referred to in points (d), (f), (h), and (i) of Article II.13.1 the termination shall take effect on the day following the date on which notification of termination is received by the contractor.

### **II.13.3. Effects of termination**

In the event of termination, the contractor shall waive any claim for consequential damages, including any loss of anticipated profits for uncompleted work. On receipt of the notification of termination, the contractor shall take all the appropriate measures to minimise costs, prevent damages, and cancel or reduce its commitments. The contractor shall have 60 days from the date of termination to draw up the documents required by the special conditions for the tasks already executed on the date of termination and produce an invoice if necessary. The contracting authority may recover any amounts paid under the contract.

The contracting authority may claim compensation for any damage suffered in the event of termination.

On termination the contracting authority may engage any other contractor to deliver the supplies or provide or complete the related services. The contracting authority shall be entitled to claim from the contractor all extra costs incurred in this regard, without prejudice to any other rights or guarantees it may have under the contract.

## **ARTICLE II.14 – REPORTING AND PAYMENTS**

### **II.14.1 Date of payment**

Payments shall be deemed to be effected on the date when they are debited to the contracting authority's account.

### **II.14.2 Currency**

The contract shall be in euros.

Payments shall be executed in euros or in the local currency as provided for in Article I.5.

Conversion between the euro and another currency shall be made according to the daily euro exchange rate published in the *Official Journal of the European Union* or, failing that, at the monthly accounting exchange rate established by the European Commission and published on its website, applicable on the day on which the payment order is issued by the contracting authority.

### **II.14.3 Costs of transfer**

The costs of the transfer shall be borne in the following way:

- (a) costs of dispatch charged by the bank of the contracting authority shall be borne by the contracting authority,

- (b) cost of receipt charged by the bank of the contractor shall be borne by the contractor,
- (c) costs for repeated transfer caused by one of the parties shall be borne by the party causing repetition of the transfer.

#### **II.14.4 Invoices and Value Added Tax**

Invoices shall contain the contractor's identification, the amount, the currency and the date, as well as the contract reference.

Invoices shall indicate the place of taxation of the contractor for value added tax (VAT) purposes and shall specify separately the amounts not including VAT and the amounts including VAT.

The contracting authority is, as a rule, exempt from all taxes and duties, including VAT, pursuant to the provisions of Articles 3 and 4 of the Protocol on the Privileges and Immunities of the European Union.

The contractor shall accordingly complete the necessary formalities with the relevant authorities to ensure that the supplies and services required for performance of the contract are exempt from taxes and duties, including VAT exemption.

#### **II.14.5 Pre-financing and performance guarantees**

Pre-financing guarantees shall remain in force until the pre-financing is cleared against interim payments or payment of the balance and, in case the latter takes the form of a debit note, three months after the debit note is notified to the contractor. The contracting authority shall release the guarantee within the following month.

Performance guarantees shall cover delivery of supplies and performance of the related services in accordance with the terms set out in the tender specifications until their final acceptance by the contracting authority. The amount of a performance guarantee shall not exceed the total price of the contract. The guarantee shall provide that it remains in force until final acceptance. The contracting authority shall release the guarantee within a month following the date of final acceptance.

Where, in accordance with Article I.4, a financial guarantee is required for the payment of pre-financing, or as performance guarantee, it shall fulfill the following conditions:

- (a) the financial guarantee is provided by a bank or an approved financial institution or, at the request of the contractor and agreement by the contracting authority, by a third party;
- (b) the guarantor stands as first-call guarantor and does not require the contracting authority to have recourse against the principal debtor (the contractor).

The cost of providing such guarantee shall be borne by the contractor.

#### **II.14.6 Interim payments and payment of the balance**

The contractor shall submit an invoice for interim payment following receipt of the certificate of conformity of the supplies signed by the contracting authority, accompanied by a progress report or any other documents, as provided for in Article I.4 or in the tender specifications.

The contractor shall submit an invoice for payment of the balance within 60 days following receipt of the certificate of conformity of the supplies signed by the contracting authority, accompanied by a final progress report or any other documents provided for in Article I.4 or in the tender specifications.

Upon receipt, the contracting authority shall pay the amount due as interim or final payment within the periods specified in Article I.4, provided the invoice and documents have been approved and without prejudice to Article II.14.7. Approval of the invoice and documents shall not imply recognition of the regularity or of the authenticity, completeness and correctness of the declarations and information they contain.

Payment of the balance may take the form of recovery.

#### **II.14.7 Suspension of the time allowed for payment**

The contracting authority may suspend the payment periods specified in Article I.4 at any time by notifying the contractor that its invoice cannot be processed, either because it does not comply with the provisions of the contract, or because the appropriate documents have not been produced.

The contracting authority shall inform the contractor in writing as soon as possible of any such suspension, giving the reasons for it.

Suspension shall take effect on the date the notification is sent by the contracting authority. The remaining payment period shall start to run again from the date on which the requested information or revised documents are received or the necessary further verification, including on-the-spot checks, is carried out. Where the suspension period exceeds two months, the contractor may request the contracting authority to justify the continued suspension.

Where the payment periods have been suspended following rejection of a document referred to in the first paragraph and the new document produced is also rejected, the contracting authority reserves the right to terminate the contract in accordance with Article II.13.1(c).

#### **II.14.8. Interest on late payment**

On expiry of the payment periods specified in Article I.4, and without prejudice to Article II.14.7, the contractor is entitled to interest on late payment at the rate applied by the European Central Bank for its main refinancing operations in Euros (the reference rate), plus eight points. The reference rate shall be the rate in force on the first day of the month in which the payment period ends, as published in the C series of the *Official Journal of the European Union*.

The suspension of the payment periods in accordance with Article II.14.7 may not be considered as a late payment.

Interest on late payment shall cover the period running from the day following the due date for payment up to and including the date of actual payment as defined in Article II.14.1.

However, when the calculated interest is lower than or equal to EUR 200, it shall be paid to the contractor only upon request submitted within two months of receiving late payment.



**Article II.15 – Recovery**

**II.15.1** If an amount is to be recovered under the terms of the contract, the contractor shall repay the contracting authority the amount in question according to the terms and by the date specified in the debit note.

**II.15.2** If the obligation to pay the amount due is not honoured by the date set by the contracting authority in the debit note, the amount due shall bear interest at the rate indicated in Article II.14.8. Interest on late payments shall cover the period from the day following the due date for payment, up to and including the date when the contracting authority receives full payment of the amount owed.

Any partial payment shall first be entered against charges and interest on late payment and then against the principal amount.

**II.15.3** If payment has not been made by the due date, the contracting authority may, after informing the contractor in writing, recover the amounts due by offsetting them against any amounts owed to the contractor by the Union or by the European Atomic Energy Community or by calling in the financial guarantee, where provided for in Article I.4.

**ARTICLE II.16 – CHECKS AND AUDITS**

**II.16.1** The contracting authority and the European Anti-Fraud Office may check or have an audit on the performance of the contract. It may be carried out either directly by its own staff or by any other outside body authorised to do so on its behalf.

Such checks and audits may be initiated during the performance of the contract and during a period of five years which starts running from the date of the payment of the balance.

The audit procedure shall be deemed to be initiated on the date of receipt of the relevant letter sent by the contracting authority. Audits shall be carried out on a confidential basis.

**II.16.2** The contractor shall keep all original documents stored on any appropriate medium, including digitised originals when they are authorised by national law and under the conditions laid down therein, for a period of five years which starts running from the date of payment of the balance.

**II.16.3** The contractor shall allow the contracting authority's staff and outside personnel authorised by the contracting authority the appropriate right of access to sites and premises where the contract is performed and to all the information, including information in electronic format, needed in order to conduct such checks and audits. The contractor shall ensure that the information is readily available at the moment of the check or audit and, if so requested, that information be handed over in an appropriate form.

**II.16.4** On the basis of the findings made during the audit, a provisional report shall be drawn up. It shall be sent to the contractor, which shall have 30 days following the date of receipt to submit observations. The final report shall be sent to the contractor within 60 days following the expiry of that deadline.

On the basis of the final audit findings, the contracting authority may recover all or part of the payments made and may take any other measure which it considers necessary.

**II.16.5** By virtue of Council Regulation (Euratom, EC) No 2185/96 of 11 November 1996 concerning on-the-spot checks and inspection carried out by the Commission in order to protect the European Communities' financial interests against fraud and other irregularities and Regulation (EC) No 1073/1999 of the European Parliament and the Council of 25 May 1999 concerning investigation conducted by the European Anti-Fraud Office (OLAF), the OLAF may also carry out on-the-spot checks and inspections in accordance with the procedures laid down by Union and Community law for the protection of the financial interests of the Union and of the Community against fraud and other irregularities. Where appropriate, the findings may lead to recovery by the contracting authority.

**II.16.6** The Court of Auditors shall have the same rights as the contracting authority, notably right of access, for the purpose of checks and audits.